

-20°C ÷ 100°C with NBR o-ring
 -15°C ÷ 200°C with Viton o-ring
 The working temperature is determined by the properties of the tube used



Working pressure:
 60 Bar
 20 Bar (1110-3PCS)



Compressed air, water, oil and fluids suitable with construction materials



- Taper gas BSPT ISO 7 from R1/8" to R1"
- Parallel gas BSPP ISO 228 from G1/8" to G1"
- Metric ISO 262 M5



Body: Nickel-plated brass
 - Turning: UNI EN 12164 CW614N
 - Hot forging & machining: UNI EN 12165 CW617N
 - 1322 & 1110-3PCS: Yellow brass UNI EN 12165 CW614N
 O-ring: NBR or Viton

AVAILABILITY:

- Available on request and with minimum quantity in yellow brass
- Available on request with NBR or Viton o-ring



Products in compliance with EC Regulation 1907/2006



Products in compliance with the directive EU 2015/863

CONSTRUCTION DETAILS

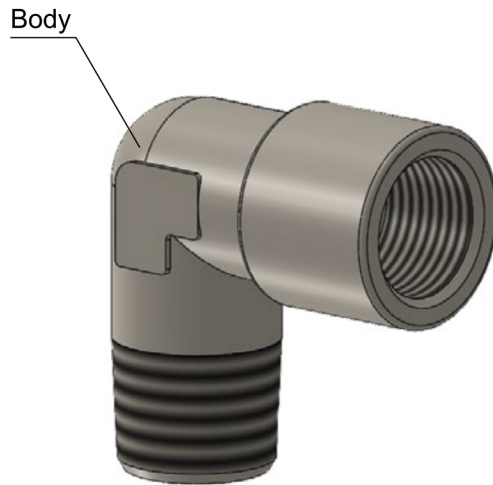

TIGHTENING TORQUE
 TAPER GAS BSPT ISO 7

THREAD	1/8"	1/4"	3/8"	1/2"	3/4"	1"
Nm	8	12	14	16	18	20

TIGHTENING TORQUE
 PARALLEL GAS BSPP ISO 228 & METRIC ISO 262

THREAD	M5x0,8	1/8"	1/4"	3/8"	1/2"	3/4"	1"
Nm	0,8	1,2	1,5	2,5	3,5	4,5	5,5



1105

Nipple BSPP & metric thread

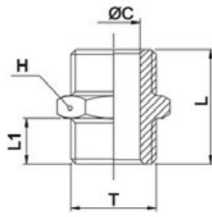

CODE	T	ØC	L	L1	H	g
1105TRM5	M5x0,8	2,5	11,0	4	8	2,0
1105TR18	G 1/8"	6,0	18,5	7	14	9,0
1105TR14	G 1/4"	8,5	21,0	8	17	15,0
1105TR38	G 3/8"	11,5	23,0	9	19	21,0
1105TR12	G 1/2"	15,0	25,0	10	24	34,0
1105TR34	G 3/4"	20,0	27,5	11	30	53,0
1105TR1	G 1"	26,0	32,0	13	36	84,0

1106

Nipple BSPP thread with NBR O-ring

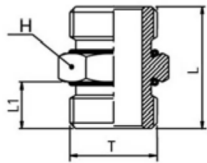

CODE	T	L	L1	H	g
1106TR18	G 1/8"	14	6,5	17,5	8,0
1106TR14	G 1/4"	17	8	21	16,0
1106TR38	G 3/8"	20	9	23	24,0
1106TR12	G 1/2"	24	10	26	38,0

1107

Reduced nipple BSPP & metric thread

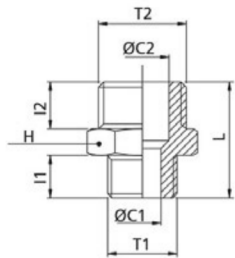

CODE	T1	T2	ØC1	ØC2	I1	I2	L	H	g
1107TRM518	M5x0,8	G 1/8"	2,5	6,0	5,0	6,5	15,5	14	7,0
1107TR1814	G 1/8"	G 1/4"	5,5	8,5	6,5	8,0	19,0	17	14,0
1107TR1838	G 1/8"	G 3/8"	5,5	11,5	6,5	9,0	20,5	19	19,0
1107TR1438	G 1/4"	G 3/8"	8,5	11,5	8,0	9,0	22,0	19	19,0
1107TR1412	G 1/4"	G 1/2"	8,0	15,0	9,0	10,0	24,5	24	35,0
1107TR3812	G 3/8"	G 1/2"	11,0	15,0	9,0	10,0	24,5	24	36,0
1107TR3834	G 3/8"	G 3/4"	11,0	20,0	10,0	11,0	26,5	30	52,0
1107TR1234	G 1/2"	G 3/4"	15,0	20,0	11,0	11,0	27,5	30	52,0
1107TR341	G 3/4"	G 1"	20,0	25,5	11,0	13,0	30,0	36	71,0

1108

Reduced nipple BSPP thread with NBR O-ring

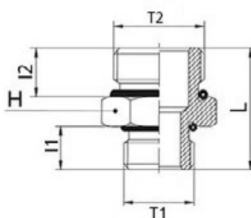

CODE	T1	T2	L	I1	I2	H	g
1108TR1814	G 1/8"	G 1/4"	19,5	6,5	8	17	14,0
1108TR1838	G 1/8"	G 3/8"	21	6,5	9	20	22,0
1108TR1438	G 1/4"	G 3/8"	22	8	9	20	24,0
1108TR1412	G 1/4"	G 1/2"	24	8	10	24	34,0
1108TR3812	G 3/8"	G 1/2"	25	9	10	24	34,0



1110

Nipple BSPT thread

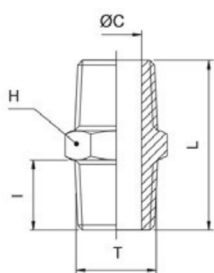

CODE	T	ØC	I	L	H	g
1110TR18	R 1/8"	6,0	7,5	19,0	12	7,0
1110TR14	R 1/4"	7,5	11,0	26,5	14	16,0
1110TR38	R 3/8"	11,5	11,0	27,0	17	23,0
1110TR12	R 1/2"	15,0	12,5	30,5	22	79,0
1110TR34	R 3/4"	20,0	14,0	34,5	27	61,0
1110TR1	R 1"	26,0	15,5	37,0	34	92,0

1112

Reduced nipple BSPT thread

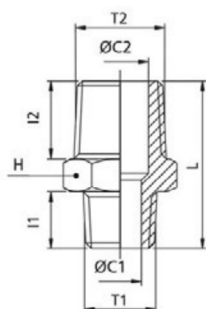

CODE	T1	T2	ØC1	ØC2	I1	I2	L	H	g
1112TR1814	R 1/8"	R 1/4"	5,5	8,5	7,5	11,0	23,0	14	12,0
1112TR1838	R 1/8"	R 3/8"	5,5	11,5	7,5	11,0	23,5	17	19,0
1112TR1438	R 1/4"	R 3/8"	8,5	11,5	10,5	11,0	26,5	17	21,0
1112TR1412	R 1/4"	R 1/2"	8,0	15,0	10,5	12,5	28,5	22	32,0
1112TR3812	R 3/8"	R 1/2"	11,0	15,0	10,5	12,5	28,5	22	35,0
1112TR1234	R 1/2"	R 3/4"	15,0	20,0	12,5	14,0	32,5	27	58,0
1112TR341	R 3/4"	R 1"	20,0	25,5	13,0	15,5	35,5	34	91,0

1113

Swivel male nipple 3 pieces BSPT thread

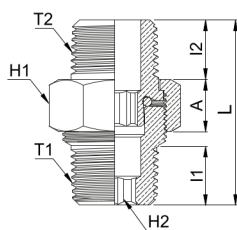

CODE	T1	T2	L	I1	I2	A	H1	H2
1113TR1818	R 1/8"	R 1/8"	28,5	9,0	9,0	9	15	4
1113TR1414	R 1/4"	R 1/4"	34,0	11,0	11,0	10	19	5
1113TR3838	R 3/8"	R 3/8"	35,5	11,5	11,5	10	22	8
1113TR1212	R 1/2"	R 1/2"	41,0	14,0	14,0	11	27	10



1115

Enlarger M/F BSPP & metric thread

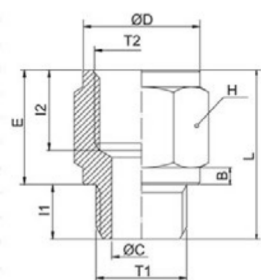

CODE	T1	T2	B	ØC	ØD	I1	I2	E	L	H	g
1115TRM5	M5x0,8	M5x0,8	1,5	2,5	7,5	4,5	5,0	6,5	11,0	8	3,0
1115TRM518	M5x0,8	G 1/8"	2,0	2,2	13,5	5,0	7,0	11,0	16,0	14	10,0
1115TRM618	M6x1	G 1/8"	2,0	2,7	13,5	6,0	7,0	11,0	17,0	14	10,0
1115TR18	G 1/8"	G 1/8"	2,0	5,5	13,5	6,5	8,0	11,0	17,5	14	11,0
1115TR1814	G 1/8"	G 1/4"	2,0	5,5	16,5	6,5	10,5	13,5	20,0	17	18,0
1115TR1838	G 1/8"	G 3/8"	2,5	5,5	21,5	6,5	10,5	14,0	20,5	22	33,0
1115TR14	G 1/4"	G 1/4"	2,0	8,5	16,5	8,0	10,5	13,5	21,5	17	19,0
1115TR1438	G 1/4"	G 3/8"	2,5	8,0	21,5	9,0	10,5	14,0	23,0	22	32,0
1115TR1412	G 1/4"	G 1/2"	3,0	8,0	26,5	9,0	12,5	17,0	26,0	27	51,0
1115TR38	G 3/8"	G 3/8"	2,5	11,0	21,5	9,0	10,5	14,0	23,0	22	32,0
1115TR3812	G 3/8"	G 1/2"	3,0	11,0	26,5	9,0	12,5	17,0	26,0	27	54,0
1115TR3834	G 3/8"	G 3/4"	3,0	11,0	31,5	9,0	12,5	17,0	26,0	32	66,0
1115TR12	G 1/2"	G 1/2"	3,0	15,0	26,5	10,5	12,5	16,0	26,5	27	56,0
1115TR1234	G 1/2"	G 3/4"	3,0	15,0	31,5	10,5	12,5	17,0	27,5	32	71,0
1115TR121	G 1/2"	G 1"	3,0	15,0	37,5	11,0	12,5	18,0	29,0	38	93,0
1115TR34	G 3/4"	G 3/4"	3,0	20,0	31,5	10,5	12,5	17,0	27,5	32	69,0
1115TR341	G 3/4"	G 1"	3,0	20,0	37,5	11,0	12,5	18,0	29,0	38	93,0
1115TR1	G 1"	G 1"	3,0	26,0	37,5	13,0	12,5	18,0	31,0	38	96,0

1116

Enlarger M/F BSPP thread with NBR O-ring

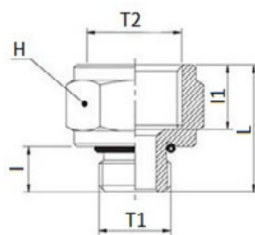

CODE	T1	T2	L	I	I1	H	g
1116TR18	G 1/8"	G 1/8"	17,0	6,5	8,5	17	12,3
1116TR1814	G 1/8"	G 1/4"	20,0	6,5	11	20	13,0
1116TR1838	G 1/8"	G 3/8"	21,0	6,5	11,5	21	31,0
1116TR14	G 1/4"	G 1/4"	21,5	8	11	21,5	18,0
1116TR1438	G 1/4"	G 3/8"	22,5	8	11,5	22,5	32,0
1116TR1412	G 1/4"	G 1/2"	26,0	9	14	26	36,0
1116TR38	G 3/8"	G 3/8"	23,5	9	11,5	23,5	32,0
1116TR3812	G 3/8"	G 1/2"	27,0	9	14	27	38,0

1118

Swivel nipple M/F BSPP thread with NBR O-ring

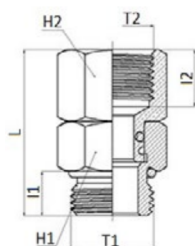

CODE	T1	T2	I1	I2	L	H1	H2	g
1118TR18	G 1/8"	G 1/8"	6,5	8	27,0	13	13	2,0
1118TR14	G 1/4"	G 1/4"	8	11	32,0	16	16	32,0
1118TR38	G 3/8"	G 3/8"	9	11,5	33,5	19	19	44,0



1120

Enlarger M/F, male BSPT thread & female BSPP thread

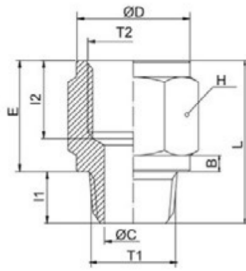

CODE	T1	T2	B	ØC	ØD	I1	I2	E	L	H	g
1120TR18	R 1/8"	G 1/8"	2,0	5,5	13,5	7,5	8	11,0	18,5	14	12,0
1120TR1814	R 1/8"	G 1/4"	2,0	5,5	16,5	7,5	10,5	13,5	21,0	17	18,0
1120TR1838	R 1/8"	G 3/8"	2,5	5,5	21,5	7,5	10,5	14,0	21,5	22	31,0
1120TR14	R 1/4"	G 1/4"	2,0	8,5	16,5	10,5	10,5	13,5	24,0	17	18,0
1120TR1438	R 1/4"	G 3/8"	2,5	8,0	21,5	10,5	10,5	14,0	24,5	22	32,0
1120TR1412	R 1/4"	G 1/2"	3,0	8,0	26,5	10,5	12,5	17,0	27,5	27	52,0
1120TR38	R 3/8"	G 3/8"	2,5	11,0	21,5	10,5	10,5	14,0	24,5	22	37,0
1120TR3812	R 3/8"	G 1/2"	3,0	11,0	26,5	10,5	12,5	17,0	27,5	27	55,0
1120TR3834	R 3/8"	G 3/4"	3,0	11,0	31,5	11,0	12,5	17,0	28,0	32	74,0
1120TR12	R 1/2"	G 1/2"	3,0	15,0	26,5	12,5	12,5	16,0	28,5	27	54,0
1120TR1234	R 1/2"	G 3/4"	3,0	15,0	31,5	12,5	12,5	17,0	29,5	32	70,0
1120TR121	R 1/2"	G 1"	3,0	15,0	37,5	13,0	12,5	18,0	31,0	38	91,0
1120TR34	R 3/4"	G 3/4"	3,0	20,0	31,5	13,0	12,5	17,0	30,0	32	74,0
1120TR341	R 3/4"	G 1"	3,0	20,0	37,5	13,0	12,5	18,0	31,0	38	97,0
1120TR1	R 1"	G 1"	3,0	26,0	37,5	15,5	12,5	18,0	33,5	38	100,0

1122

Swivel enlarger M/F, male BSPT thread & female BSPP thread

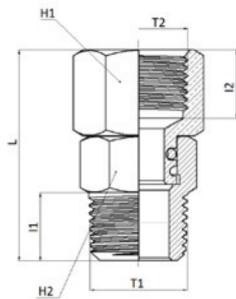

CODE	T1	T2	I1	I2	L	H1	H2	g
1122TR18	R 1/8"	R 1/8"	8	8	28	12	13	2,0
1122TR14	R 1/4"	R 1/4"	11	11	34	14	16	3,0
1122TR1838	R 1/8"	R 3/8"	11,5	11,5	35,5	17	19	42,0

1125

Female sleeve BSPP & metric thread

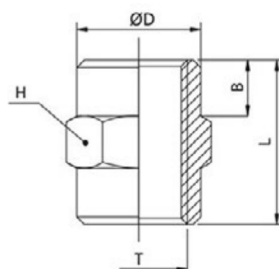

CODE	T	ØD	B	L	H	g
1125TRM5	M5x0,8	7,5	3,5	11,0	8	3,0
1125TR18	G 1/8"	13,5	5,0	15,0	14	10,0
1125TR14	G 1/4"	16,5	8,0	22,0	17	18,0
1125TR38	G 3/8"	21,5	8,5	24,0	22	37,0
1125TR12	G 1/2"	26,5	10,0	29,0	27	62,0
1125TR34	G 3/4"	31,5	10,0	29,0	32	70,0
1125TR1	G 1"	37,5	11,0	31,0	38	89,0



1126

Reduced female sleeve BSPP & metric thread

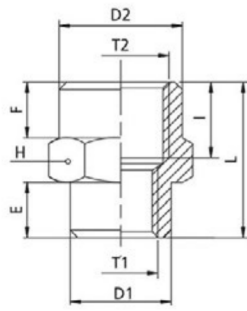

CODE	T1	T2	ØD1	ØD2	I	E	F	L	H	g
1126TRM518	M5x0,8	G 1/8"	8,0	13,5	7,0	3,5	4,5	12,5	14	9,0
1126TR1814	G 1/8"	G 1/4"	13,0	16,5	11,0	6,0	8,0	20,0	17	18,0
1126TR1838	G 1/8"	G 3/8"	14,0	21,5	11,0	6,0	8,0	20,0	22	28,0
1126TR1438	G 1/4"	G 3/8"	17,0	21,5	11,0	7,0	8,0	21,0	22	30,0
1126TR1412	G 1/4"	G 1/2"	17,0	26,5	13,0	8,0	9,0	24,0	27	46,0
1126TR3812	G 3/8"	G 1/2"	21,5	26,5	13,0	8,0	9,0	24,0	27	48,0
1126TR3834	G 3/8"	G 3/4"	21,0	31,5	13,5	8,0	10,0	25,0	32	64,0
1126TR1234	G 1/2"	G 3/4"	26,0	31,5	13,5	8,0	10,0	25,0	32	65,0
1126TR121	G 1/2"	G 1"	26,0	37,0	14,0	8,0	10,0	25,0	38	84,0
1126TR341	G 3/4"	G 1"	32,0	37,0	14,0	8,0	10,0	25,0	38	83,0

1130

Extension M/F BSPP thread

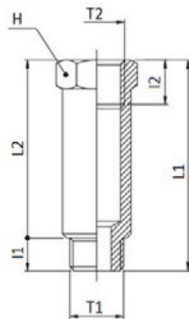

CODE	T1	T2	I1	I2	L1	L2	H	g
1130TR181422	G 1/8"	G 1/8"	6	8,0	22	16	14	14,0
1130TR181442	G 1/8"	G 1/8"	6	8,0	42	36	14	30,0
1130TR181451	G 1/8"	G 1/8"	6	8,0	51	45	14	36,0
1130TR141735	G 1/4"	G 1/4"	8	11,0	35	27	17	32,0
1130TR141751	G 1/4"	G 1/4"	8	11,0	51	43	17	46,0

1135

Reduced M/F BSPP & metric thread

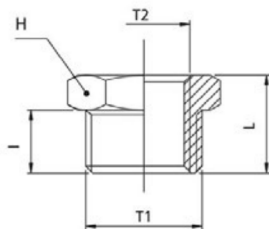

CODE	T1	T2	I	L	H	g
1135TRM518	G 1/8"	M5x0,8	6,5	10,5	14	7,0
1135TR1418	G 1/4"	G 1/8"	8,0	12,5	17	10,0
1135TR3818	G 3/8"	G 1/8"	9,0	14,0	19	18,0
1135TR3814	G 3/8"	G 1/4"	9,0	14,0	19	13,0
1135TR1218	G 1/2"	G 1/8"	10,0	15,0	24	39,0
1135TR1214	G 1/2"	G 1/4"	10,0	15,0	24	32,0
1135TR1238	G 1/2"	G 3/8"	10,0	15,0	24	21,0
1135TR3414	G 3/4"	G 1/4"	11,0	16,5	30	64,0
1135TR3438	G 3/4"	G 3/8"	11,0	16,5	30	52,0
1135TR3412	G 3/4"	G 1/2"	11,0	16,5	30	36,0
1135TR138	G 1"	G 3/8"	13,5	19,5	36	110,0
1135TR112	G 1"	G 1/2"	13,0	19,0	36	90,0
1135TR134	G 1"	G 3/4"	13,0	19,0	36	59,0



1136

Reduced M/F BSPP & metric thread with NBR O-ring

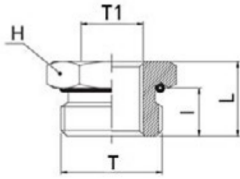

CODE	T	T1	I	L	H	g
1136TRM518	M5x0,8	G 1/8"	6,5	11	14	8,0
1136TR1418	G 1/4"	G 1/8"	8	13	17	10,0
1136TR3818	G 3/8"	G 1/8"	9	14	20	12,0
1136TR3814	G 3/8"	G 1/4"	9	14	20	14,0
1136TR1218	G 1/2"	G 1/8"	10	15,5	24	38,0
1136TR1214	G 1/2"	G 1/4"	10	15,5	24	39,0
1136TR1238	G 1/2"	G 3/8"	10	15,5	24	40,0

1140

Reduced male BSPT thread & female BSPP thread

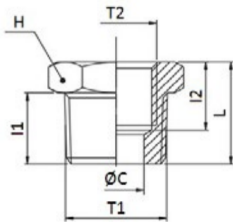

CODE	T1	T2	ØC	I1	I2	L	H	g
1140TR1418	R 1/4"	G 1/8"	6,0	11,0	9,0	15,5	14	9,0
1140TR3818	R 3/8"	G 1/8"	6,5	11,0	9,0	15,5	17	21,0
1140TR3814	R 3/8"	G 1/4"	8,5	11,0	11,0	15,5	17	13,0
1140TR1218	R 1/2"	G 1/8"	6,0	12,5	10,0	18,0	22	42,0
1140TR1214	R 1/2"	G 1/4"	8,5	12,5	11,5	18,0	22	34,0
1140TR1238	R 1/2"	G 3/8"	11,5	12,5	11,5	18,0	22	25,0
1140TR3414	R 3/4"	G 1/4"	8,5	14,0	12,0	20,0	27	74,0
1140TR3438	R 3/4"	G 3/8"	11,5	14,0	12,0	20,0	27	62,0
1140TR3412	R 3/4"	G 1/2"	15,0	14,0	14,0	20,0	27	43,0
1140TR138	R 1"	G 3/8"	15,0	15,5	13,0	21,5	34	123,0
1140TR112	R 1"	G 1/2"	15,0	15,5	14,0	21,5	34	144,0
1140TR134	R 1"	G 3/4"	20,0	15,5	14,0	21,5	34	173,0

1145

Male plug BSPP & metric thread

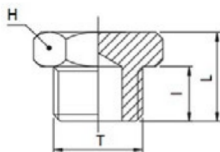

CODE	T	I	L	H	g
1145TRM5	M5x0,8	4,5	7,5	8	4,0
1145TR18	G 1/8"	6,0	10,0	14	7,0
1145TR14	G 1/4"	8,0	12,5	17	12,0
1145TR38	G 3/8"	9,0	13,5	19	19,0
1145TR12	G 1/2"	10,0	15,0	24	28,0
1145TR34	G 3/4"	11,0	16,5	30	46,0
1145TR1	G 1"	12,5	18,5	36	79,0



1148

Male plug BSPP & metric thread with exagon embedded

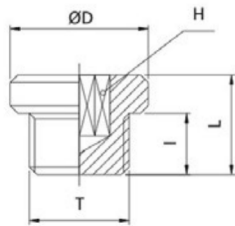

CODE	T	I	L	ØD	H	g
1148TRM5	M5x0,8	4,0	6,5	8	2,5	2,0
1148TR18	G 1/8"	6,0	10,0	15	5	8,0
1148TR14	G 1/4"	8,0	12,0	18	6	12,0
1148TR38	G 3/8"	9,0	13,0	21	8	22,0
1148TR12	G 1/2"	10,0	14,5	25	10	36,0
1148TR34	G 3/4"	11,0	15,5	31	14	-
1148TR1	G 1"	12,5	17,5	38	17	-

1149

Male plug BSPP & metric thread with exagon embedded and NBR O-ring

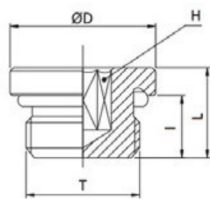

CODE	T	I	L	ØD	H	g
1149TRM5	M5x0,8	4,5	7,2	8,0	2,5	1,4
1149TR18	G 1/8"	6,5	9,5	14,0	5	6,0
1149TR14	G 1/4"	8,0	11,5	17,0	6	12,0
1149TR38	G 3/8"	9,0	12,5	20,0	8	18,0
1149TR12	G 1/2"	10,0	14,0	26,0	10	32,0

1150

Male plug BSPT thread

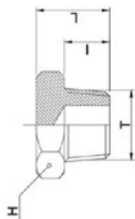

CODE	T	I	L	H	g
1150TR18	R 1/8"	7,5	11,5	10	4,0
1150TR14	R 1/4"	11,0	15,5	14	9,0
1150TR38	R 3/8"	11,0	16,0	17	17,0
1150TR12	R 1/2"	12,0	17,5	22	29,0
1150TR34	R 3/4"	13,5	19,5	27	60,0
1150TR1	R 1"	15,5	22,0	34	92,0

1152

Male plug BSPP thread with O-ring

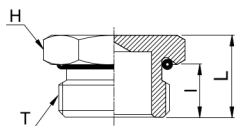

CODE	T	I	L	H	g
1152TR18	G 1/8"	6,5	10,5	14	-
1152TR14	G 1/4"	8,0	12,5	17	-
1152TR38	G 3/8"	9,0	13,5	20	-
1152TR12	G 1/2"	10,0	15,5	24	-



1155

Female plug BSPP & metric thread

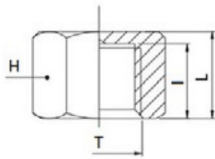
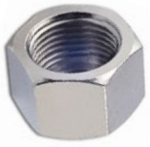

CODE	T	I	L	H	g
1155TRM5	M5x0,8	5,5	7,0	8	2,0
1155TR18	G 1/8"	9,0	11,0	14	5,0
1155TR14	G 1/4"	11,0	13,0	17	17,0
1155TR38	G 3/8"	11,0	13,5	21	23,0
1155TR12	G 1/2"	11,0	13,5	24	44,0
1155TR34	G 3/4"	12,5	15,0	30	44,0
1155TR1	G 1"	12,5	15,0	38	56,0

1160

Male plug BSPP thread with exagon embedded

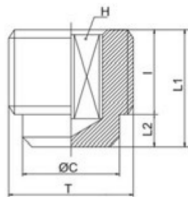

CODE	T	I	ØC	L1	L2	H	g
1160TR18	G 1/8"	4,0	8,0	7,0	3,0	5	2,0
1160TR14	G 1/4"	6,0	10,5	10,0	4,0	6	6,0
1160TR38	G 3/8"	6,0	13,5	10,0	4,0	8	10,0
1160TR12	G 1/2"	6,5	17,5	11,0	4,0	10	13,0

1161

Male flat plug BSPT thread with exagon embedded

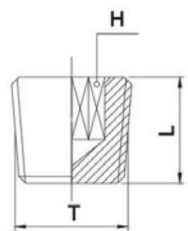

CODE	T	L	H	g
1161TR18	R 1/8"	8,0	5	3,0
1161TR14	R 1/4"	10,0	6	7,0
1161TR38	R 3/8"	10,5	8	23,0
1161TR12	R 1/2"	13,0	10	24,0
1161TR34	R 3/4"	15,5	14	32,0
1161TR1	R 1"	17,5	17	45,0

1175

Nut BSPP & metric thread

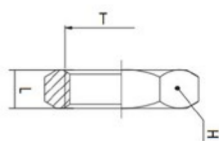

CODE	T	L	H	g
1175TRM5	M5x0,8	2,5	9	1,0
1175TR18	G 1/8"	3,5	12	3,0
1175TR14	G 1/4"	4,0	16	2,0
1175TR38	G 3/8"	4,5	19	3,0
1175TR12	G 1/2"	4,5	24	6,0
1175TR34	G 3/4"	5,0	30	10,0
1175TR1	G 1"	6,0	38	20,0



1176

Bulkhead locking nut metric thread

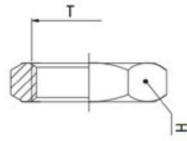

CODE	T	H	g
1176TRM101	M10x1	14	3,0
1176TRM121	M12x1	16	3,8
1176TRM1615	M16x1,5	19	5,0
1176TRM1815	M18x1,5	22	7,0
1176TRM2015	M20x1,5	24	18,0
1176TRM2215	M22x1,5	25	17,0
1176TRM2615	M26x1,5	32	21,0
1176TRM2815	M28x1,5	36	23,0

1200

Elbow F/F BSPP & metric thread

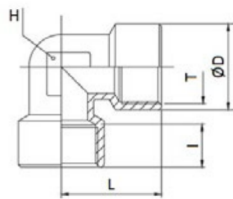

CODE	T	I	ØD	L	H	g
1200TRM5	M5x0,8	5,5	9,0	11,0	8	6,0
1200TR18	G 1/8"	8,0	13,5	20,5	10	19,0
1200TR14	G 1/4"	11,5	16,5	31,0	13	33,0
1200TR38	G 3/8"	12,0	21,0	36,0	17	57,0
1200TR12	G 1/2"	15,0	26,0	44,0	21	109,0
1200TR34	G 3/4"	16,5	32,0	36,5	25	144,0
1200TR1	G 1"	19,0	39,0	45,0	30	244,0

1205

Elbow male BSPT thread and female BSPP & metric thread

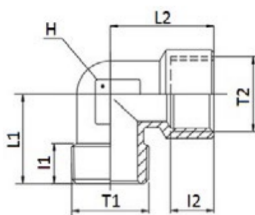

CODE	T1	T2	I1	I2	L1	L2	H	g
1205TRM5	M5x0,8	M5x0,8	5,0	5,5	11,5	11	8	7,0
1205TR18	R 1/8"	G 1/8"	9,5	8,0	17,5	19,5	10	16,0
1205TR14	R 1/4"	G 1/4"	11,5	11,5	24,0	25	13	31,0
1205TR38	R 3/8"	G 3/8"	13,0	12,0	27,5	27,5	17	46,0
1205TR12	R 1/2"	G 1/2"	15,0	15,0	30,0	33,5	21	92,0
1205TR34	R 3/4"	G 3/4"	16,0	16,5	33,0	36,5	25	120,0
1205TR1	R 1"	G 1"	17,0	19,0	39,0	45,0	30	212,0

1210

Elbow M/M BSPT & metric thread

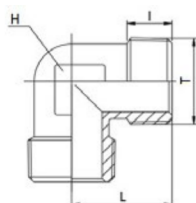

CODE	T	I	L	H	g
1210TRM5	M5x0,8	5,0	13,5	8	6,0
1210TR18	R 1/8"	9,0	18,5	10	13,0
1210TR14	R 1/4"	11,5	22,0	12	20,0
1210TR38	R 3/8"	13,0	26,0	13	31,0
1210TR12	R 1/2"	14,0	28,5	17	55,0
1210TR34	R 3/4"	16,0	33,0	25	100,0
1210TR1	R 1"	17,0	39,0	30	174,0

1215

Equal female cross BSPP thread

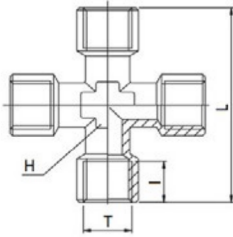

CODE	T	I	L	H	g
1215TR18	G 1/8"	8,0	42,0	10	38,0
1215TR14	G 1/4"	11,0	51,0	13	76,0
1215TR38	G 3/8"	11,5	56,0	17	108,0
1215TR12	G 1/2"	14,0	67,0	21	186,0

1216

Equal cross male BSPT thread & female BSPP thread

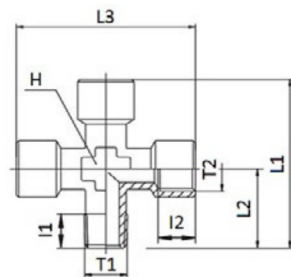

CODE	T1	T2	I1	I2	L1	L2	L3	H	g
1216TR18	R 1/8"	G 1/8"	8,0	8,0	39,5	18,5	42	10	34,0
1216TR14	R 1/4"	G 1/4"	11,0	11,0	49,0	23,5	51	13	68,0
1216TR38	R 3/8"	G 3/8"	11,5	11,5	54,0	26,0	56	17	100,0
1216TR12	R 1/2"	G 1/2"	14,0	14,0	64,5	31,0	67	21	168,0

1218

Equal cross male BSPT thread & female BSPP thread

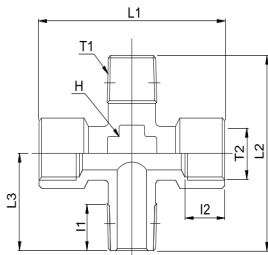

CODE	T1	T2	I1	I2	L1	L2	L3	H	g
1218TR14	R 1/4"	G 1/4"	11	11	51,0	47,0	23,5	13	-

1220

Female tee BSPP & metric thread

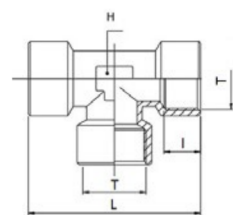

CODE	T	I	L	H	g
1220TRM5	M5x0,8	5,5	26,5	8	7,0
1220TR18	G 1/8"	8,0	40,0	10	28,0
1220TR14	G 1/4"	11,5	50,0	13	49,0
1220TR38	G 3/8"	12,0	57,0	17	85,0
1220TR12	G 1/2"	15,0	68,5	21	146,0
1220TR34	G 3/4"	16,5	73,0	25	194,0
1220TR1	G 1"	19,0	90,0	30	326,0



1225

Tee M/M/F, male BSPT & metric and female BSPP & metric thread

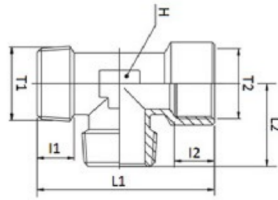

CODE	T1	T2	I1	I2	L1	L2	H	g
1225TRM5	M5x0,8	M5x0,8	5,0	5,5	26,0	13,0	8	8,0
1225TR18	R 1/8"	G 1/8"	9,5	8,0	38,5	18,5	10	25,0
1225TR14	R 1/4"	G 1/4"	11,5	11,5	47,5	23,5	13	43,0
1225TR38	R 3/8"	G 3/8"	13,0	12,0	56,0	26,0	17	72,0
1225TR12	R 1/2"	G 1/2"	15,0	15,0	67,5	32,0	21	102,0
1225TR34	R 3/4"	G 3/4"	16,0	16,5	69,5	33,0	25	156,0
1225TR1	R 1"	G 1"	17,5	19,0	84,0	39,0	30	268,0

1230

Male tee BSPT & metric thread

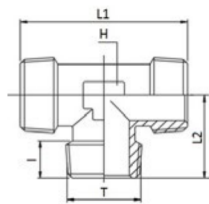

CODE	T	I	L1	L2	H	g
1230TRM5	M5x0,8	5,0	27,5	13,5	8	8,0
1230TR18	R 1/8"	9,5	36,0	17,0	10	20,0
1230TR14	R 1/4"	11,5	48,0	24,0	12	38,0
1230TR38	R 3/8"	12,0	48,0	24,0	13	47,0
1230TR12	R 1/2"	15,0	57,0	28,0	17	80,0
1230TR34	R 3/4"	16,2	66,4	33,0	25	134,0
1230TR1	R 1"	17,5	78,0	39,0	30	236,0

1235

Tee male BSPT & metric and female BSPP & metric thread

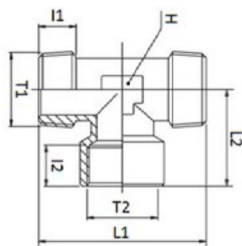

CODE	T1	T2	I1	I2	L1	L2	H	g
1235TRM5	M5x0,8	M5x0,8	5,0	5,5	27,5	13,0	8	6,0
1235TR18	R 1/8"	G 1/8"	9,5	8,0	36,5	19,5	10	22,0
1235TR14	R 1/4"	G 1/4"	11,5	11,5	48,0	25,5	13	37,0
1235TR38	R 3/8"	G 3/8"	13,0	12,0	51,5	28,0	17	62,0
1235TR12	R 1/2"	G 1/2"	15,0	15,0	63,0	34,0	21	118,0
1235TR34	R 3/4"	G 3/4"	16,0	16,5	66,4	36,5	25	156,0
1235TR1	R 1"	G 1"	17,5	19,0	78,0	45,0	30	268,0

1240

Tee male BSPT & metric and female BSPP & metric thread

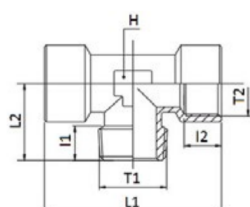

CODE	T1	T2	I1	I2	L1	L2	H	g
1240TRM5	M5x0,8	M5x0,8	5,0	5,5	26,5	11,5	8	9,0
1240TR18	R 1/8"	G 1/8"	9,5	8,0	40,0	18,5	10	22,0
1240TR14	R 1/4"	G 1/4"	11,5	11,5	50,0	24,5	13	49,0
1240TR38	R 3/8"	G 3/8"	13,0	12,0	57,0	26,5	17	75,0
1240TR12	R 1/2"	G 1/2"	15,0	15,0	68,5	32,0	21	127,0
1240TR34	R 3/4"	G 3/4"	16,0	16,5	73,0	33,0	25	178,0
1240TR1	R 1"	G 1"	17,5	19,0	90,0	39,0	30	296,0



1245

Tee male BSPT & metric and female BSPP & metric thread

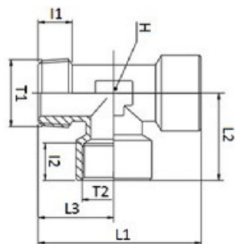

CODE	T1	T2	I1	I2	L1	L2	L3	H	g
1245TRM5	M5x0,8	M5x0,8	5,0	5,5	26,0	13,0	12,0	8	9,0
1245TR18	R 1/8"	G 1/8"	9,5	8,0	38,5	19,5	18,5	10	24,0
1245TR14	R 1/4"	G 1/4"	11,5	11,5	49,0	25,0	24,0	13	44,0
1245TR38	R 3/8"	G 3/8"	13,0	12,0	54,0	28,5	25,5	17	74,0
1245TR12	R 1/2"	G 1/2"	15,0	15,0	65,5	34,5	31,0	21	132,0
1245TR34	R 3/4"	G 3/4"	16,0	16,5	69,5	36,5	33,0	25	172,0
1245TR1	R 1"	G 1"	17,5	19,0	84,0	45,0	39,0	30	298,0

1300

Y male BSPT thread & female BSPP thread

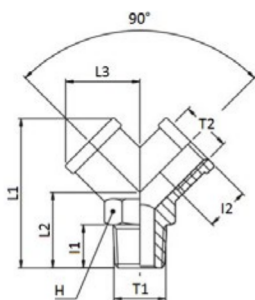

CODE	T1	T2	I1	I2	L1	L2	L3	H	g
1300TR18	R 1/8"	G 1/8"	8,0	8,0	32,0	16	14,5	13	22,0
1300TR14	R 1/4"	G 1/4"	11,0	11,0	38,0	20	18,0	17	38,0
1300TR38	R 3/8"	G 3/8"	11,5	11,5	42,5	22	20,5	20	52,0
1300TR12	R 1/2"	G 1/2"	14,0	14,0	53,0	27	26,5	25	110,0

1310

Female Y BSPP thread

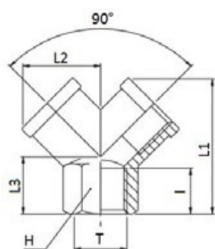

CODE	T	I	L1	L2	L3	H	g
1310TR18	G 1/8"	8,0	26,5	14,5	12	13	18,0
1310TR14	G 1/4"	11,0	32,0	18,0	14	17	32,0
1310TR38	G 3/8"	11,5	37,0	20,5	16	20	44,0
1310TR12	G 1/2"	14,0	45,0	26,5	19	25	92,0

1320

Female bulkhead connector BSPP & metric thread

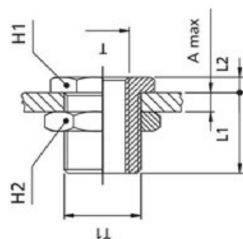

CODE	T	T1	A MAX	L1	L2	H1	H2	g
1320TRM5M101	M5x0,8	M10x1	7	10,5	3,5	14	14	12,0
1320TR18M1615	G 1/8"	M16x1,5	10	14,0	4,0	19	22	30,0
1320TR14M2015	G 1/4"	M20x1,5	16	21,0	4,0	24	27	58,0
1320TR38M2615	G 3/8"	M26x1,5	15	21,0	5,0	30	32	94,0
1320TR12M2815	G 1/2"	M28x1,5	21	27,0	6,0	32	36	116,0

