

# Vacuum Pad

Ø 20, Ø 25, Ø 35, Ø 50

New

RoHS

Good for film packaging applications where the shape of the workpiece changes easily from being lifted.

Silicone rubber compliant with the FDA (USA Food and Drug Administration) 21CFR§177.2600 elution test is used.

## Blue coloured pad

Easy to distinguish the vacuum pad by colour during contamination inspection.

## Reduced leakage

Sealing skirt design, better sealing performance even for thin films.

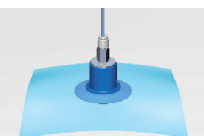
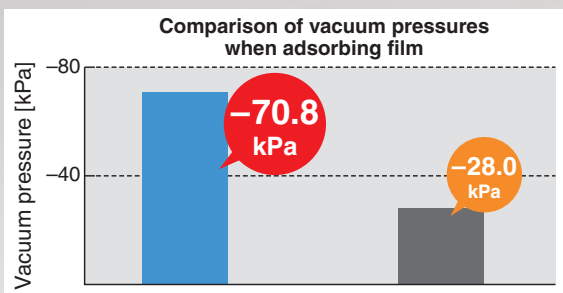

Pad for film packaging application

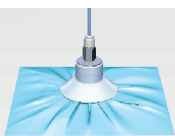

Flat type pad/  
Flat type pad with ribs

## Reduction of wrinkles made on thin workpieces (film, vinyl, etc.) during adsorption

Wrinkle prevention with the stopper in the centre of the vacuum pad

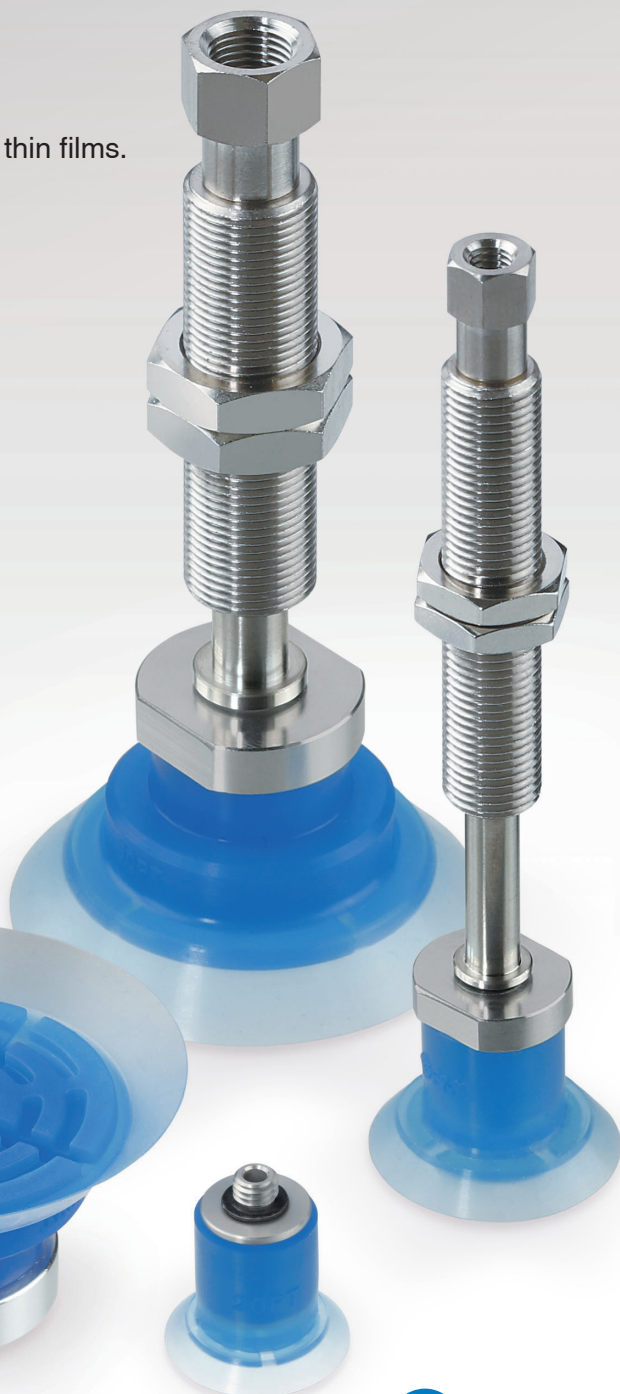





ZP3P Series



CAT.EUS100-122A-UK

**Variations**

	Form	Pad Diameter				Vacuum Inlet / Mounting	Buffer Stroke	Page
		Ø 20	Ø 25	Ø 35	Ø 50			
Pad Unit		●	●	●	●	—	—	2
With Adapter	Male thread 	●	●	●	●	M5 x 0.8, M12 x 1.75 G1/8, G1/4, G3/8	—	3
	Female thread 	●	●	●	●	M5 x 0.8 M8 x 1.25	—	
With Buffer	Female thread 	●	●	●	●	Vacuum inlet: M5 x 0.8, Rc1/8 Mounting: M10 x 1, M14 x 1	10 mm/20 mm	6

# INDEX

## Vacuum Pad

Ø 20, Ø 25, Ø 35, Ø 50

■ **Pad Unit**

How to Order ..... p. 2  
 Dimensions ..... p. 2

■ **Vertical Vacuum Inlet, With Adapter**

How to Order ..... p. 3  
 Dimensions ..... p. 3

■ **Vertical Vacuum Inlet, With Buffer**

How to Order ..... p. 6  
 Dimensions ..... p. 6

Construction ..... p. 9  
 Parts Structure ..... p. 10  
 Mounting Adapter Part Nos. .... p. 11  
 Buffer Assembly Part Nos. .... p. 12





# Vacuum Pad

Pad diameter  $\varnothing 20, \varnothing 25, \varnothing 35, \varnothing 50$

## How to Order

Pad unit **ZP3P-20PTSF**

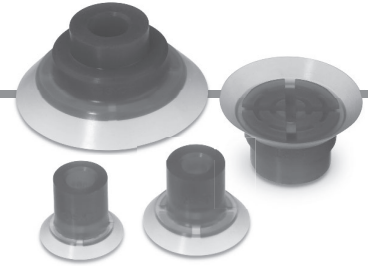

Pad diameter

Symbol	Pad diameter
20	$\varnothing 20$
25	$\varnothing 25$
35	$\varnothing 35$
50	$\varnothing 50$

### Pad material

Symbol	Material
SF	Silicone rubber Complies with the FDA (USA Food and Drug Administration) 21CFR§177.2600 elution test.

## Dimensions: Pad Unit

ZP3P-20PTSF [Weight: 1.8 g]

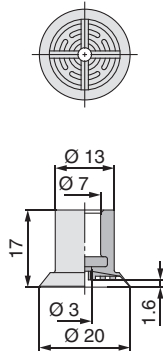

ZP3P-25PTSF [Weight: 2.2 g]

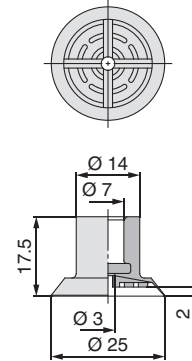

ZP3P-35PTSF [Weight: 4.7 g]

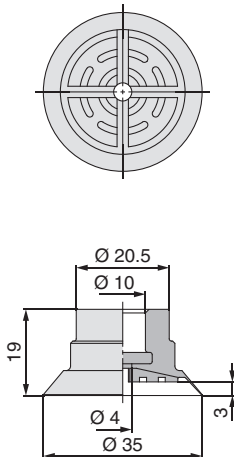

ZP3P-50PTSF [Weight: 12.4 g]

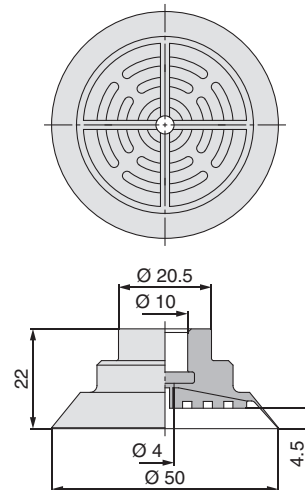

### Pad Mounting Dimensions

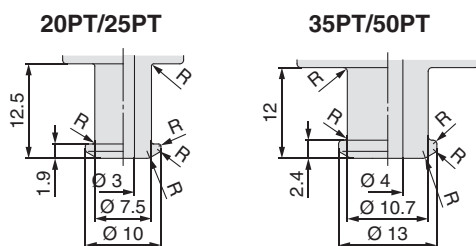

\* R part has to be smooth with no corners.

# ZP3P Series

## How to Order

Vertical vacuum inlet  
With adapter

# ZP3P   - T 20 PT SF - A5



### Adapter material

Symbol	Material
—	Aluminum
S	Stainless steel (Stainless steel 304)

### Pad diameter

Symbol	Pad diameter
20	Ø 20
25	Ø 25
35	Ø 35
50	Ø 50

### Pad material

Symbol	Material
SF	Silicone rubber*1, *2

- \*1 Compliant with the FDA (USA Food and Drug Administration) regulation 21CFR§177.2600 for "Rubber articles intended for repeated use"  
 \*2 Compliant with the standards for "Rubber apparatus (excluding baby drinking apparatus) and containers/packaging" (D3) (Partial revision: Ministry of Health, Labour, and Welfare Notification No. 595, 2012) in Section 3 "Apparatus and Containers/Packaging" of the Food Sanitation Act, Article 18 "Specifications and Standards for Food and Food Additives, etc." (Ministry of Health and Welfare Notification No. 370, 1959).

### Mounting thread size

Type	Symbol	Size	Ø 20	Ø 25	Ø 35	Ø 50
Male thread	A5	M5 x 0.8	●	●	—	—
	A12	M12 x 1.75	—	—	●	●
	AG1	G1/8	●	●	—	—
	AG2	G1/4	—	—	●	●
Female thread	B5	M5 x 0.8	●	●	—	—
	B8	M8 x 1.25	—	—	●	●

\* The pad is shipped together but does not come assembled.

## Mounting

When mounting the male thread adapter, be sure to tighten using the recommended tightening torque in the chart on the right. Tightening outside of the recommended tightening torque range may result in sealing failure or loosening of the thread.

Product part number	Connection thread size	Proper tightening torque [N·m]
ZP3P <span style="border: 1px solid black; padding: 0 5px;"> </span> -T <span style="border: 1px solid black; padding: 0 5px;"> </span> PTSF-A5	M5 x 0.8	1.2 to 1.6
ZP3P <span style="border: 1px solid black; padding: 0 5px;"> </span> -T <span style="border: 1px solid black; padding: 0 5px;"> </span> PTSF-A12	M12 x 1.75	3 to 5
ZP3P <span style="border: 1px solid black; padding: 0 5px;"> </span> -T <span style="border: 1px solid black; padding: 0 5px;"> </span> PTSF-AG1	G1/8	3 to 5
ZP3P <span style="border: 1px solid black; padding: 0 5px;"> </span> -T <span style="border: 1px solid black; padding: 0 5px;"> </span> PTSF-AG2	G1/4	8 to 12
ZP3P <span style="border: 1px solid black; padding: 0 5px;"> </span> -T <span style="border: 1px solid black; padding: 0 5px;"> </span> PTSF-AG3	G3/8	15 to 20

## Dimensions: With Male Thread Adapter

ZP3P-T20PTSF-A5 [Weight: 3.9 g]  
 ZP3PS-T20PTSF-A5 [Weight: 7.6 g]

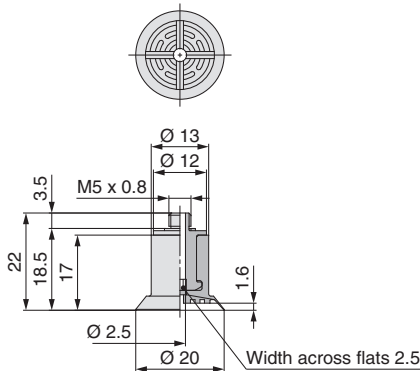

ZP3P-T20PTSF-AG1 [Weight: 5.9 g]  
 ZP3PS-T20PTSF-AG1 [Weight: 13.1 g]

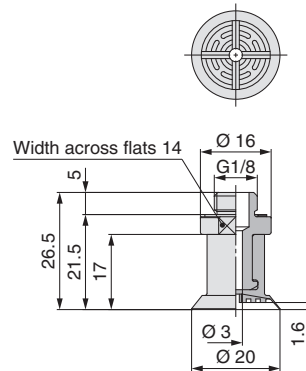

ZP3P-T25PTSF-A5 [Weight: 4.3 g]  
 ZP3PS-T25PTSF-A5 [Weight: 8.0 g]

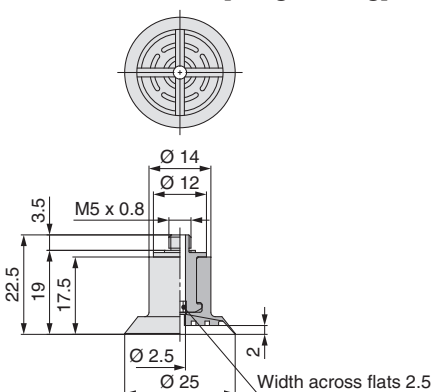

ZP3P-T25PTSF-AG1 [Weight: 6.3 g]  
 ZP3PS-T25PTSF-AG1 [Weight: 13.5 g]

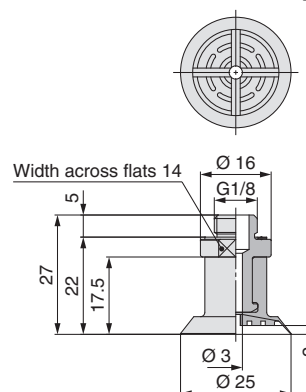

**Dimensions: With Male Thread Adapter**

**ZP3P-T35PTSF-A12 [Weight: 20.7 g]  
ZP3PS-T35PTSF-A12 [Weight: 48.3 g]**

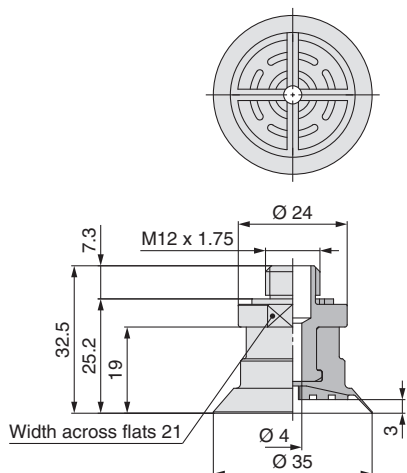

**ZP3P-T35PTSF-AG2 [Weight: 14.5 g]  
ZP3PS-T35PTSF-AG2 [Weight: 32.1 g]**

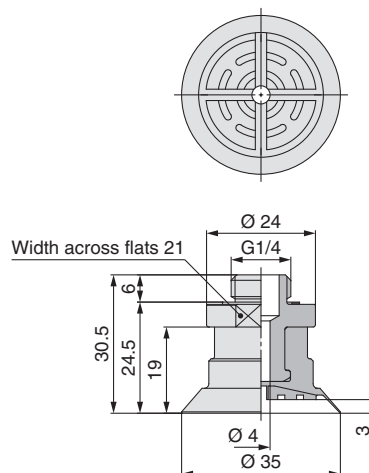

**ZP3P-T35PTSF-AG3 [Weight: 21.1 g]  
ZP3PS-T35PTSF-AG3 [Weight: 48.8 g]**

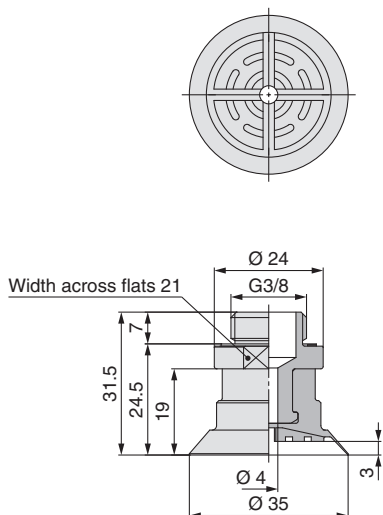

**ZP3P-T50PTSF-A12 [Weight: 28.4 g]  
ZP3PS-T50PTSF-A12 [Weight: 50.6 g]**

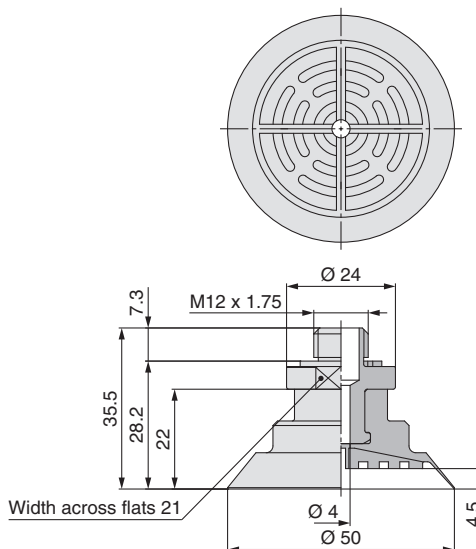

**ZP3P-T50PTSF-AG2 [Weight: 22.2 g]  
ZP3PS-T50PTSF-AG2 [Weight: 39.8 g]**

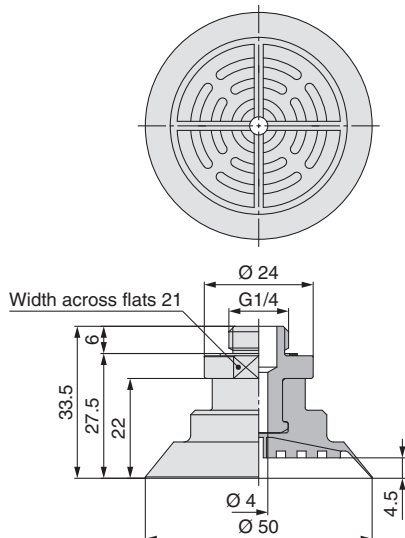

**ZP3P-T50PTSF-AG3 [Weight: 28.8 g]  
ZP3PS-T50PTSF-AG3 [Weight: 56.5 g]**

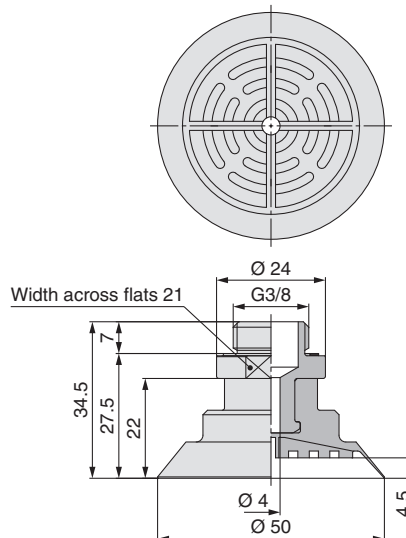

# ZP3P Series

## Dimensions: With Female Thread Adapter

ZP3P-T20PTSF-B5 [Weight: 4.9 g]

ZP3PS-T20PTSF-B5 [Weight: 10.5 g]

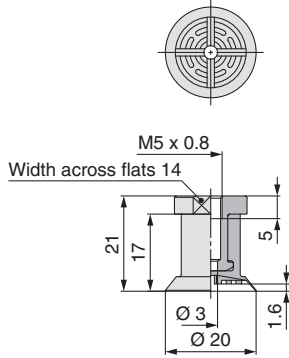

ZP3P-T25PTSF-B5 [Weight: 5.3 g]

ZP3PS-T25PTSF-B5 [Weight: 10.9 g]

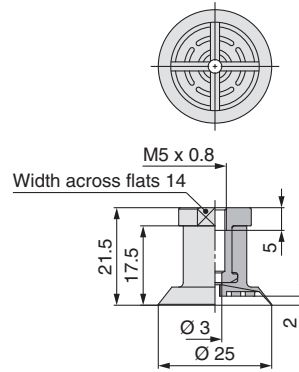

ZP3P-T35PTSF-B8 [Weight: 13.2 g]

ZP3PS-T35PTSF-B8 [Weight: 28.7 g]

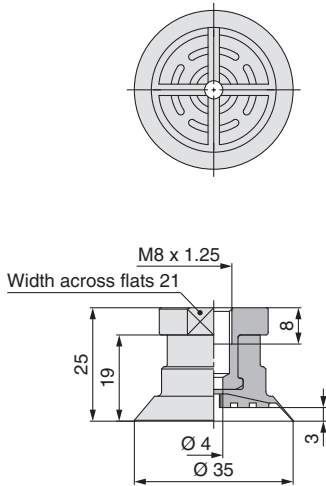

ZP3P-T50PTSF-B8 [Weight: 20.9 g]

ZP3PS-T50PTSF-B8 [Weight: 36.4 g]

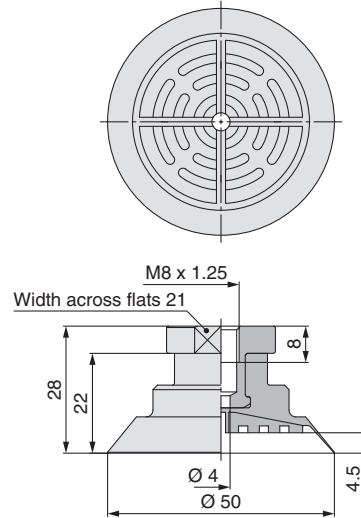

## How to Order

**Vertical vacuum inlet  
With buffer**

# ZP3P-T20PTSJ10-B5

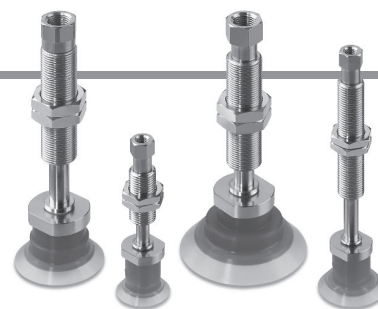

**Pad diameter**

Symbol	Pad diameter
<b>20</b>	Ø 20
<b>25</b>	Ø 25
<b>35</b>	Ø 35
<b>50</b>	Ø 50

**Pad material**

Symbol	Material
<b>SF</b>	Silicone rubber Complies with the FDA (USA Food and Drug Administration) 21CFR§177.2600 elution test.

**Buffer specification**

<b>J</b>	Rotating
<b>K</b>	Non-rotating

**Vacuum inlet**

	Symbol	Connection	Ø 20, Ø 25	Ø 35, Ø 50
Female thread	<b>B5</b>	M5 x 0.8	●	—
	<b>B01</b>	Rc1/8	—	●

**Stroke**

Symbol	Stroke	Ø 20, Ø 25	Ø 35, Ø 50
<b>10</b>	10 mm	●	●
<b>20</b>	20 mm	●	●

### Specifications

Pad diameter	Buffer specification	Stroke [mm]	Tightening torque [N·m]	Mounting	Spring reactive force [N]	
					At 0 stroke	At full stroke
Ø 20, Ø 25	<b>J/K</b>	10, 20	2.5 to 3.5	M10 x 1	1.0	3.0
Ø 35, Ø 50	<b>J/K</b>	10, 20	6.5 to 7.5	M14 x 1	2.0	5.0

## ⚠ Precautions

Be sure to read this before handling the products. Refer to the back cover for safety instructions. For vacuum equipment precautions, refer to the "Handling Precautions for SMC Products" and the "Operation Manual" on the SMC website: <http://www.smc.eu>

### Operating Precautions

#### ⚠ Caution

##### 1. Cautions for selecting buffer

Buffers have general industrial grease applied, and are therefore not compliant with FDA. Metal wear particles will be generated due to the sliding motion of the buffer. Please take this into consideration before use and decide whether this pad is suitable for your application.

### Dimensions: With Buffer

**ZP3P-T20PTSJ10-B5**

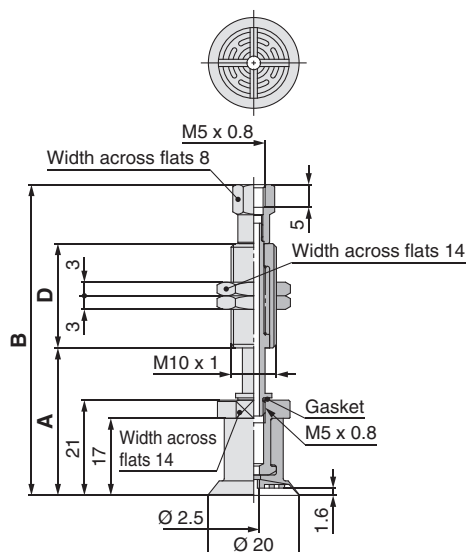

**ZP3P-T20PTSFK10-B5**

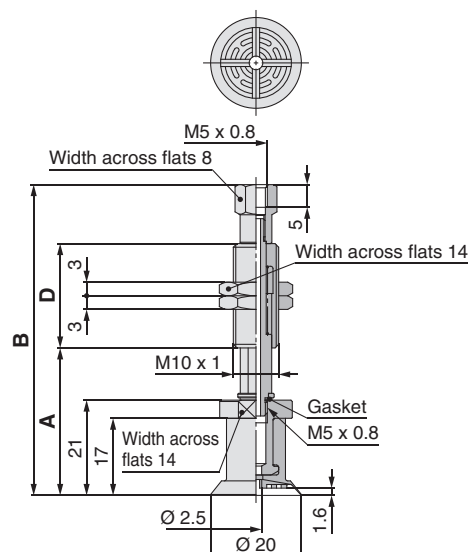

#### Dimensions

Part no.	A	B	D	Weight [g]
<b>ZP3P-T20PTSJ10-B5</b>	32.5	68.5	23	26.7
<b>ZP3P-T20PTSJ20-B5</b>	42.5	106.5	51	40.8

#### Dimensions

Part no.	A	B	D	Weight [g]
<b>ZP3P-T20PTSFK10-B5</b>	32.5	68.5	23	28.5
<b>ZP3P-T20PTSFK20-B5</b>	42.5	106.5	51	41.8

# ZP3P Series

## Dimensions: With Buffer

ZP3P-T25PTSFJ■-B5

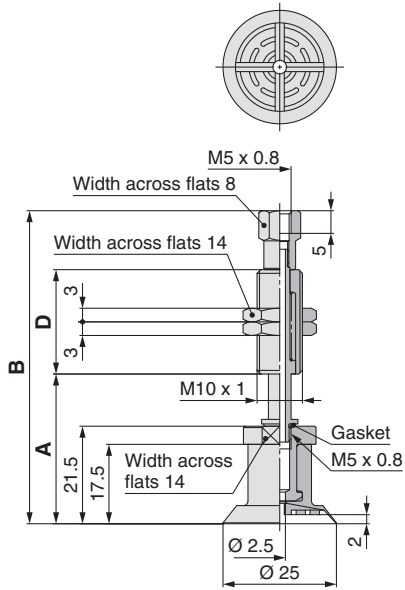

ZP3P-T25PTSFK■-B5

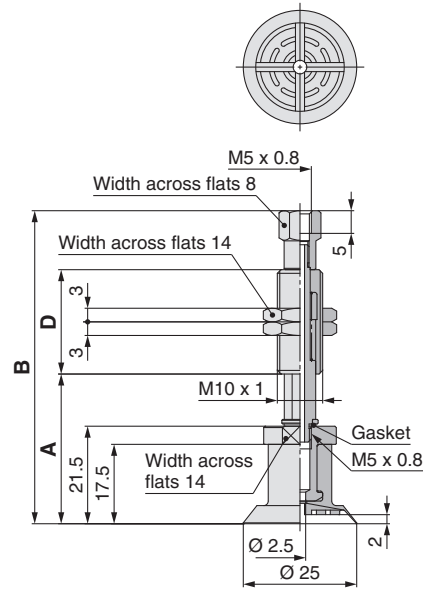

### Dimensions

Part no.	A	B	D	Weight [g]
ZP3P-T25PTSFJ10-B5	33	69	23	27.1
ZP3P-T25PTSFJ20-B5	43	107	51	41.2

### Dimensions

Part no.	A	B	D	Weight [g]
ZP3P-T25PTSFK10-B5	33	69	23	28.5
ZP3P-T25PTSFK20-B5	43	107	51	42.2

ZP3P-T35PTSFJ■-B01

ZP3P-T35PTSFJ10-B01

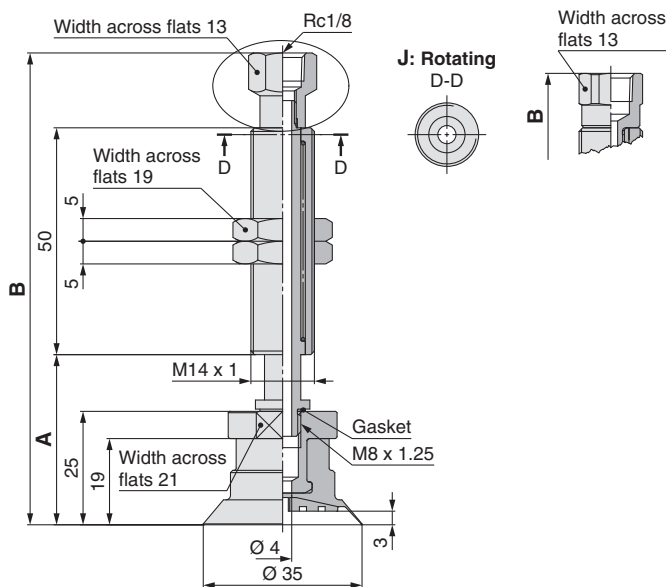
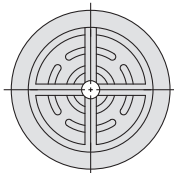

ZP3P-T35PTSFK■-B01

ZP3P-T35PTSFK10-B01

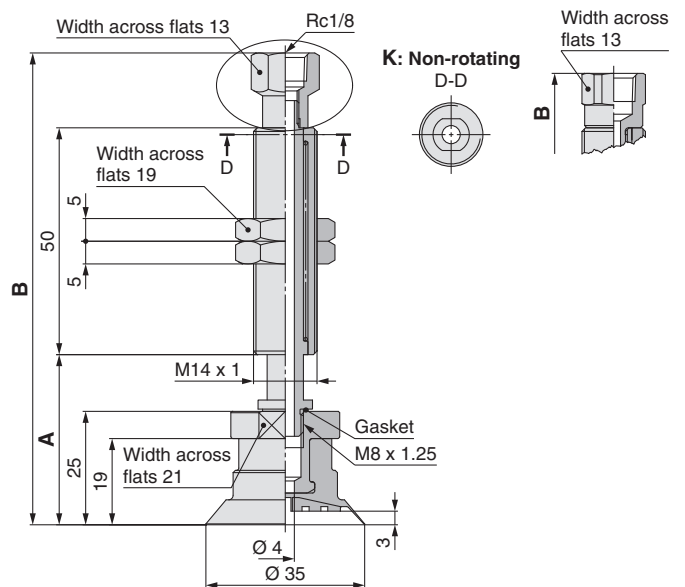
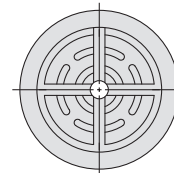

### Dimensions

Part no.	A	B	Weight [g]
ZP3P-T35PTSFJ10-B01	37.5	104	93.6
ZP3P-T35PTSFJ20-B01	47.5	109.5	94.6

### Dimensions

Part no.	A	B	Weight [g]
ZP3P-T35PTSFK10-B01	37.5	104	93.0
ZP3P-T35PTSFK20-B01	47.5	109.5	94.1



**Dimensions: With Buffer**

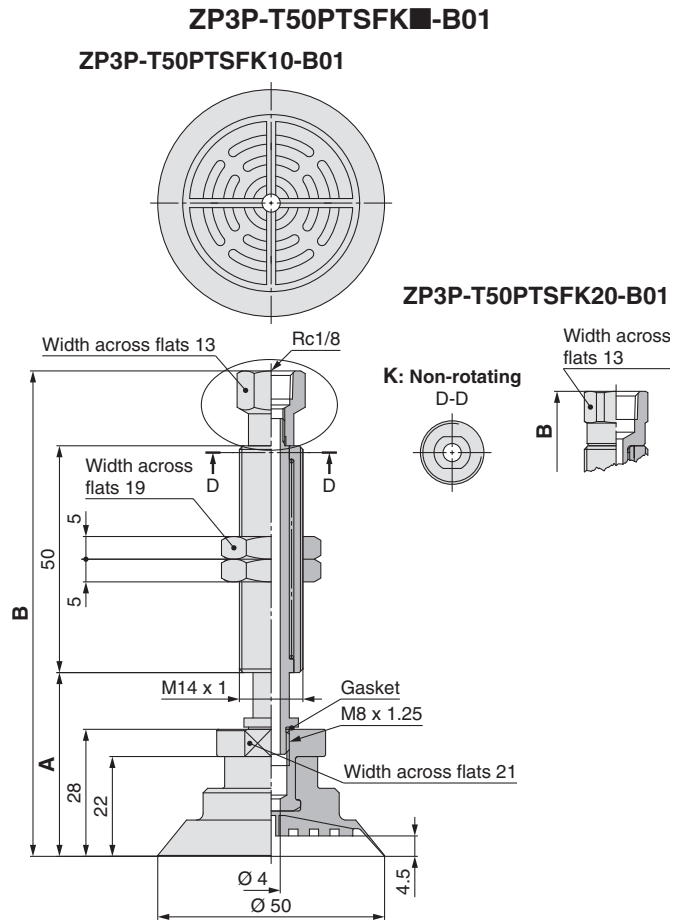
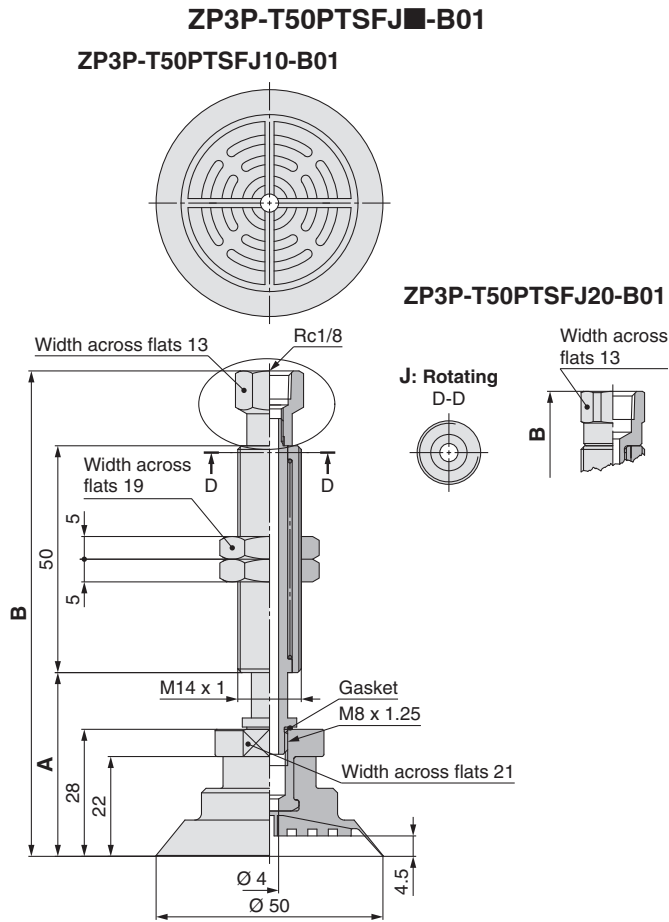

**Dimensions**

Part no.	A	B	Weight [g]
ZP3P-T50PTSFJ10-B01	40.5	107	101.3
ZP3P-T50PTSFJ20-B01	50.5	112.5	102.3

**Dimensions**

Part no.	A	B	Weight [g]
ZP3P-T50PTSFK10-B01	40.5	107	100.7
ZP3P-T50PTSFK20-B01	50.5	112.5	101.8

# ZP3P Series Construction

## Pad with Adapter

### Male thread

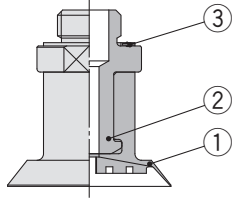

### Female thread

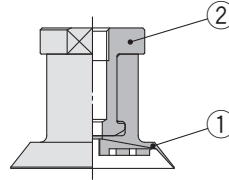

### Component Parts

No.	Description	Material (Surface treatment)	Note
1	Vacuum pad	Silicone rubber	
2	Adapter	Aluminium alloy (Clear anodized)	ZP3P-T□
		Stainless steel	ZP3PS-T□
3	Gasket	Stainless steel/NBR	ZP3P-□-(A5/AG1/AG2/AG3) ZP3PS-□-(A5/AG1/AG2/AG3)
		Stainless steel/FKM	ZP3PS-□-A5
	Seal washer	Structural steel/NBR	ZP3P-□-A12
		Stainless steel/FKM	ZP3PS-□-A12

## Pad with Buffer

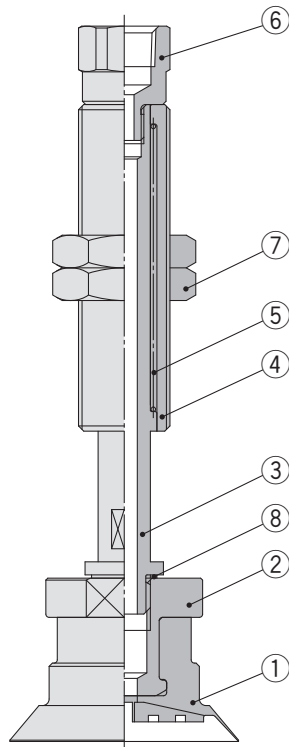

### Component Parts

No.	Description	Material (Surface treatment)
1	Vacuum pad	Silicone rubber Complies with the FDA (USA Food and Drug Administration) 21CFR§177.2600 elution test.
2	Adapter	Aluminium alloy (Clear anodised)
3	Piston rod	Stainless steel
4	Buffer body	Brass (Electroless nickel plating)
5	Return spring	Stainless steel
6	Buffer adapter	Brass (Electroless nickel plating)
7	Nut	Brass (Nickel plating)
8	Gasket	Stainless steel/NBR

# ZP3P Series Parts Structure

## With Type T Adapter

ZP3P□-T (20 to 50) PTSF-(A5/AG1/A12/AG2/AG3)

ZP3P□-T (20 to 50) PTSF-(B5/B8)

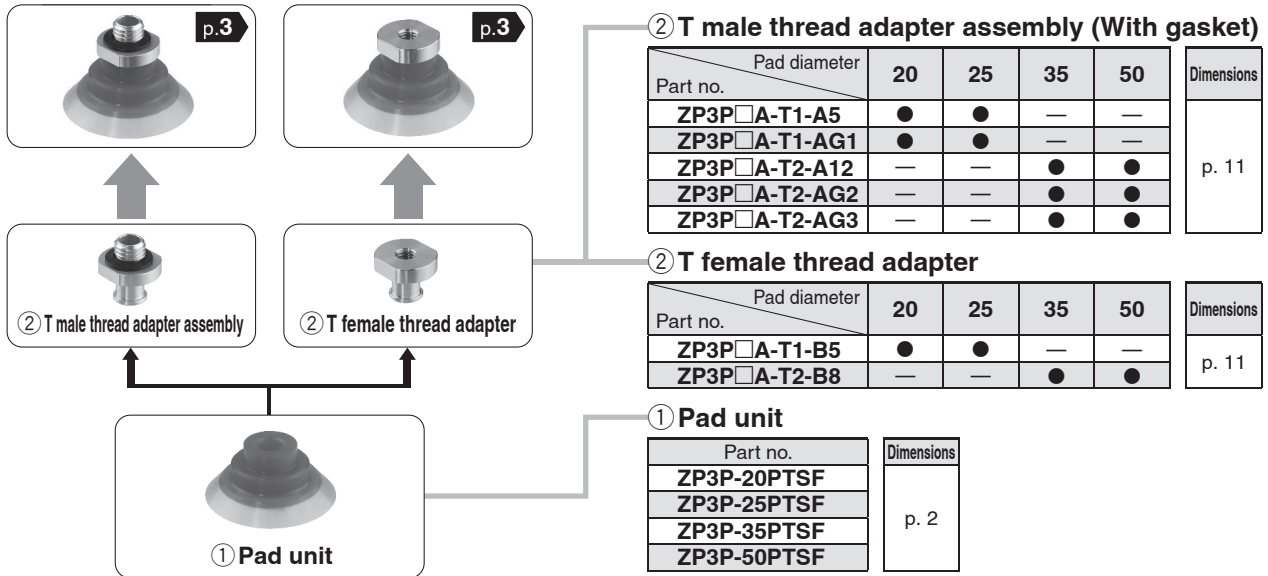

## With Buffer

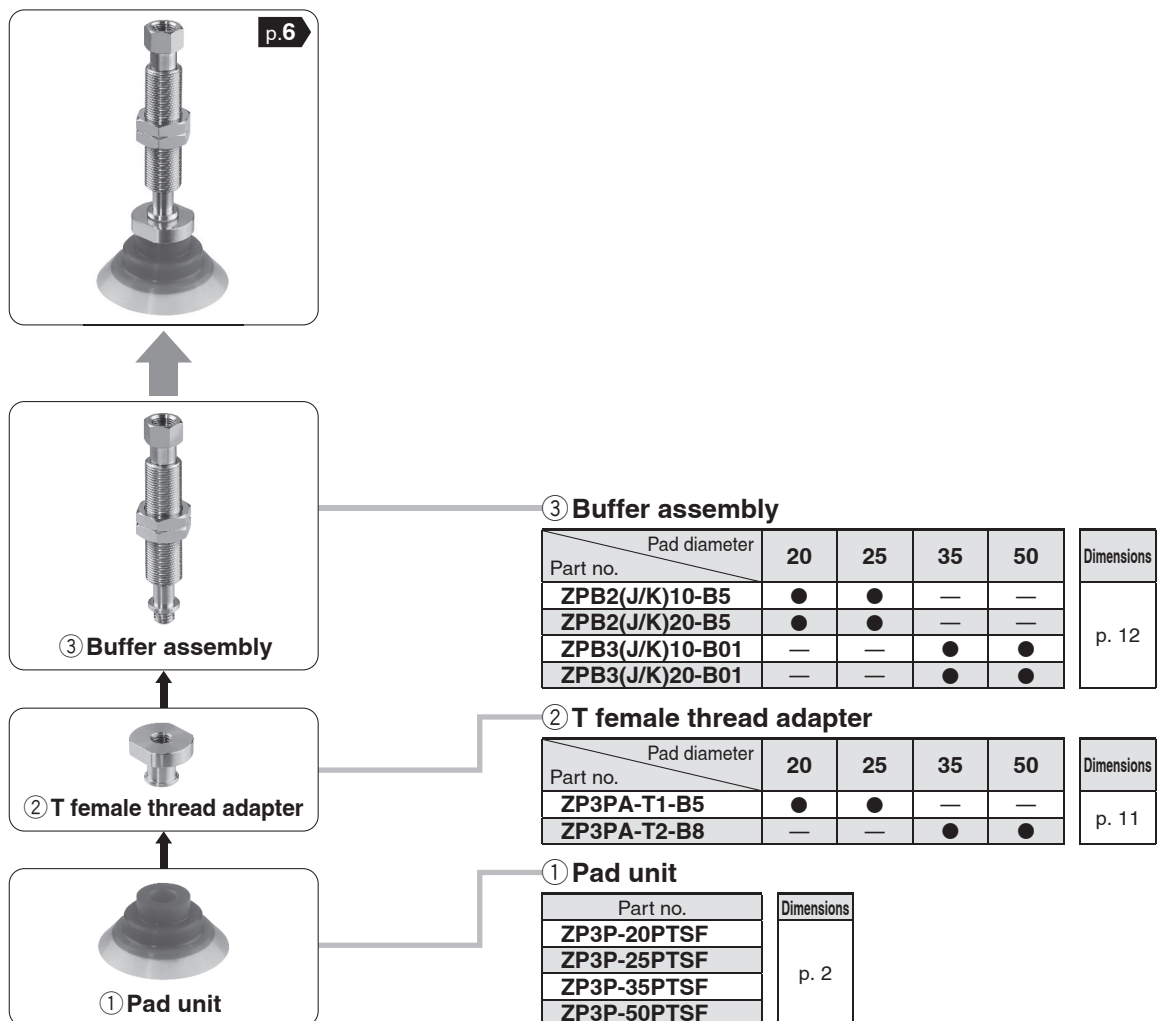

# ZP3P Series

# Mounting Adapter Part Nos.

## Male Thread Adapter

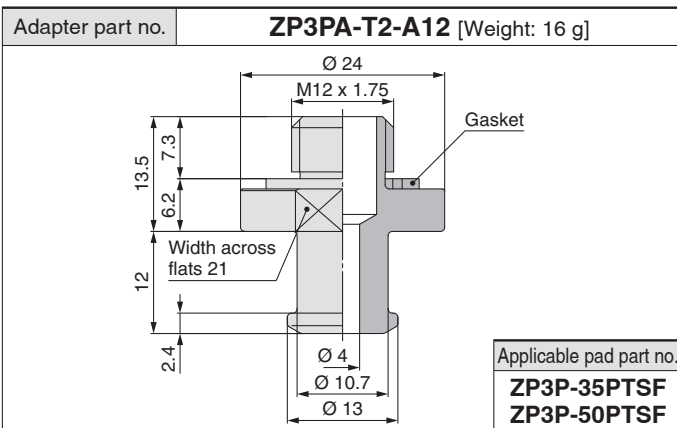
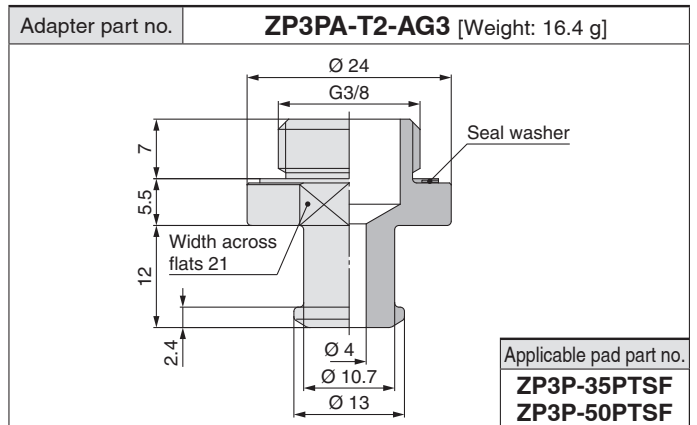
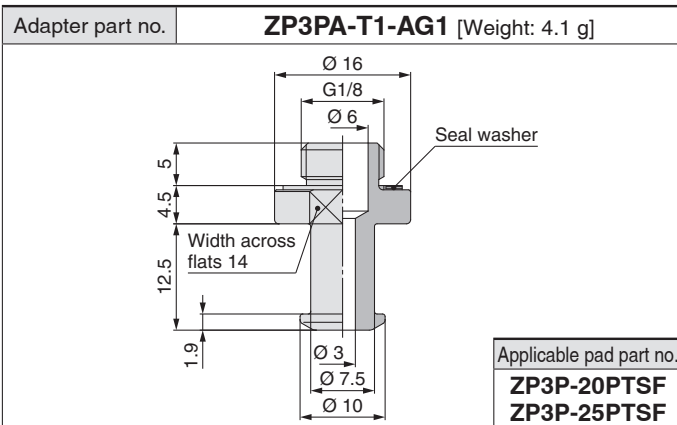
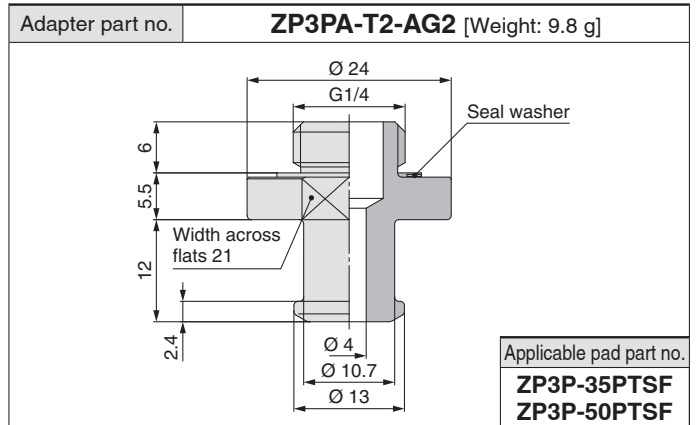
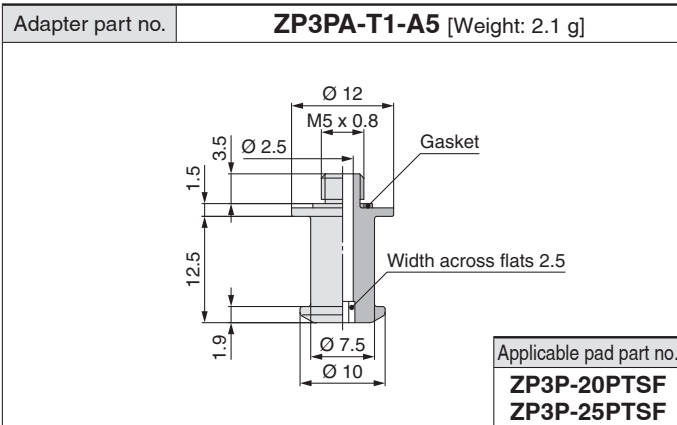

## Female Thread Adapter

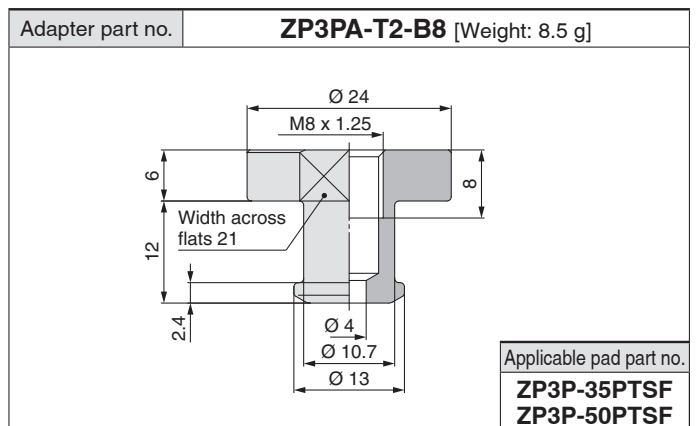
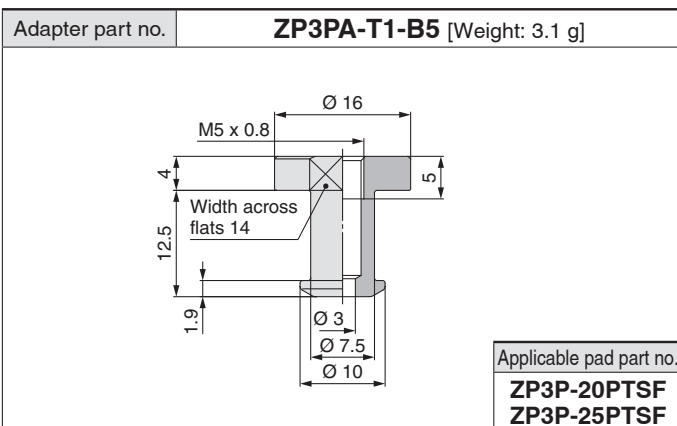

# ZP3P Series

# Buffer Assembly Part Nos.

Buffer assembly part no.	① ZPB2J10-B5 [Weight: 21.8 g]
	② ZPB2J20-B5 [Weight: 35.9 g]

**Dimensions**

Part no.	A	B	D
ZPB2J10-B5	34	47	23
ZPB2J20-B5	72	85	51

Applicable pad with adapter part no.
ZP3P-T20PTSF-B5
ZP3P-T25PTSF-B5

Buffer assembly part no.	① ZPB2K10-B5 [Weight: 23.6 g]
	② ZPB2K20-B5 [Weight: 36.9 g]

**Dimensions**

Part no.	A	B	D
ZPB2K10-B5	34	47	23
ZPB2K20-B5	72	85	51

Applicable pad with adapter part no.
ZP3P-T20PTSF-B5
ZP3P-T25PTSF-B5

Buffer assembly part no.	① ZPB3J10-B01 [Weight: 80.4 g]
	② ZPB3J20-B01 [Weight: 81.4 g]

**ZPB3J10-B01**

**J: Rotating**  
D-D

**ZPB3J20-B01**

**Dimensions**

Part no.	A	B
ZPB3J10-B01	62	78.5
ZPB3J20-B01	72	84

Applicable pad with adapter part no.
ZP3P-T35PTSF-B8
ZP3P-T50PTSF-B8

Buffer assembly part no.	① ZPB3K10-B01 [Weight: 79.8 g]
	② ZPB3K20-B01 [Weight: 80.9 g]

**ZPB3K10-B01**

**K: Non-rotating**  
D-D

**ZPB3K20-B01**



**Dimensions**

Part no.	A	B
ZPB3K10-B01	62	78.5
ZPB3K20-B01	72	84

Applicable pad with adapter part no.
ZP3P-T35PTSF-B8
ZP3P-T50PTSF-B8

## Safety Instructions

These safety instructions are intended to prevent hazardous situations and/or equipment damage. These instructions indicate the level of potential hazard with the labels of “Caution,” “Warning” or “Danger.” They are all important notes for safety and must be followed in addition to International Standards (ISO/IEC)<sup>1)</sup>, and other safety regulations.

-  **Caution:** **Caution** indicates a hazard with a low level of risk which, if not avoided, could result in minor or moderate injury.
-  **Warning:** **Warning** indicates a hazard with a medium level of risk which, if not avoided, could result in death or serious injury.
-  **Danger:** **Danger** indicates a hazard with a high level of risk which, if not avoided, will result in death or serious injury.

- 1) ISO 4414: Pneumatic fluid power – General rules relating to systems.  
ISO 4413: Hydraulic fluid power – General rules relating to systems.  
IEC 60204-1: Safety of machinery – Electrical equipment of machines.  
(Part 1: General requirements)  
ISO 10218-1: Manipulating industrial robots - Safety.  
etc.

## Warning

### 1. The compatibility of the product is the responsibility of the person who designs the equipment or decides its specifications.

Since the product specified here is used under various operating conditions, its compatibility with specific equipment must be decided by the person who designs the equipment or decides its specifications based on necessary analysis and test results. The expected performance and safety assurance of the equipment will be the responsibility of the person who has determined its compatibility with the product. This person should also continuously review all specifications of the product referring to its latest catalogue information, with a view to giving due consideration to any possibility of equipment failure when configuring the equipment.

### 2. Only personnel with appropriate training should operate machinery and equipment.

The product specified here may become unsafe if handled incorrectly. The assembly, operation and maintenance of machines or equipment including our products must be performed by an operator who is appropriately trained and experienced.

### 3. Do not service or attempt to remove product and machinery/equipment until safety is confirmed.

1. The inspection and maintenance of machinery/equipment should only be performed after measures to prevent falling or runaway of the driven objects have been confirmed.
2. When the product is to be removed, confirm that the safety measures as mentioned above are implemented and the power from any appropriate source is cut, and read and understand the specific product precautions of all relevant products carefully.
3. Before machinery/equipment is restarted, take measures to prevent unexpected operation and malfunction.

### 4. Contact SMC beforehand and take special consideration of safety measures if the product is to be used in any of the following conditions.

1. Conditions and environments outside of the given specifications, or use outdoors or in a place exposed to direct sunlight.
2. Installation on equipment in conjunction with atomic energy, railways, air navigation, space, shipping, vehicles, military, medical treatment, combustion and recreation, or equipment in contact with food and beverages, emergency stop circuits, clutch and brake circuits in press applications, safety equipment or other applications unsuitable for the standard specifications described in the product catalogue.
3. An application which could have negative effects on people, property, or animals requiring special safety analysis.
4. Use in an interlock circuit, which requires the provision of double interlock for possible failure by using a mechanical protective function, and periodical checks to confirm proper operation.

## Caution

### 1. The product is provided for use in manufacturing industries.

The product herein described is basically provided for peaceful use in manufacturing industries.

If considering using the product in other industries, consult SMC beforehand and exchange specifications or a contract if necessary. If anything is unclear, contact your nearest sales branch.

## Limited warranty and Disclaimer/Compliance Requirements

The product used is subject to the following “Limited warranty and Disclaimer” and “Compliance Requirements”. Read and accept them before using the product.

### Limited warranty and Disclaimer

1. The warranty period of the product is 1 year in service or 1.5 years after the product is delivered, whichever is first.<sup>2)</sup> Also, the product may have specified durability, running distance or replacement parts. Please consult your nearest sales branch.
  2. For any failure or damage reported within the warranty period which is clearly our responsibility, a replacement product or necessary parts will be provided. This limited warranty applies only to our product independently, and not to any other damage incurred due to the failure of the product.
  3. Prior to using SMC products, please read and understand the warranty terms and disclaimers noted in the specified catalogue for the particular products.
- 2) Vacuum pads are excluded from this 1 year warranty.  
A vacuum pad is a consumable part, so it is warranted for a year after it is delivered. Also, even within the warranty period, the wear of a product due to the use of the vacuum pad or failure due to the deterioration of rubber material are not covered by the limited warranty.

### Compliance Requirements

1. The use of SMC products with production equipment for the manufacture of weapons of mass destruction (WMD) or any other weapon is strictly prohibited.
2. The exports of SMC products or technology from one country to another are governed by the relevant security laws and regulations of the countries involved in the transaction. Prior to the shipment of a SMC product to another country, assure that all local rules governing that export are known and followed.

## Caution

### SMC products are not intended for use as instruments for legal metrology.

Measurement instruments that SMC manufactures or sells have not been qualified by type approval tests relevant to the metrology (measurement) laws of each country. Therefore, SMC products cannot be used for business or certification ordained by the metrology (measurement) laws of each country.

## Safety Instructions

Be sure to read “Handling Precautions for SMC Products” (M-E03-3) before using.

## SMC Corporation (Europe)

<b>Austria</b>	+43 (0)2262622800	www.smc.at	office@smc.at
<b>Belgium</b>	+32 (0)33551464	www.smc.be	info@smc.be
<b>Bulgaria</b>	+359 (0)2807670	www.smc.bg	office@smc.bg
<b>Croatia</b>	+385 (0)13707288	www.smc.hr	office@smc.hr
<b>Czech Republic</b>	+420 541424611	www.smc.cz	office@smc.cz
<b>Denmark</b>	+45 70252900	www.smc.dk.com	smc@smcdk.com
<b>Estonia</b>	+372 651 0370	www.smcee.ee	info@smcee.ee
<b>Finland</b>	+358 207513513	www.smc.fi	smcfi@smc.fi
<b>France</b>	+33 (0)164761000	www.smc-france.fr	supportclient@smc-france.fr
<b>Germany</b>	+49 (0)61034020	www.smc.de	info@smc.de
<b>Greece</b>	+30 210 2717265	www.smchellas.gr	sales@smchellas.gr
<b>Hungary</b>	+36 23513000	www.smc.hu	office@smc.hu
<b>Ireland</b>	+353 (0)14039000	www.smcautomation.ie	sales@smcautomation.ie
<b>Italy</b>	+39 03990691	www.smcitalia.it	mailbox@smcitalia.it
<b>Latvia</b>	+371 67817700	www.smc.lv	info@smc.lv

<b>Lithuania</b>	+370 5 2308118	www.smclt.lt	info@smclt.lt
<b>Netherlands</b>	+31 (0)205318888	www.smc.nl	info@smc.nl
<b>Norway</b>	+47 67129020	www.smc-norge.no	post@smc-norge.no
<b>Poland</b>	+48 222119600	www.smc.pl	office@smc.pl
<b>Portugal</b>	+351 214724500	www.smc.eu	apoioclientept@smc.smces.es
<b>Romania</b>	+40 213205111	www.smcromania.ro	smcromania@smcromania.ro
<b>Russia</b>	+7 (812)3036600	www.smc.eu	sales@smcru.com
<b>Slovakia</b>	+421 (0)413213212	www.smc.sk	office@smc.sk
<b>Slovenia</b>	+386 (0)73885412	www.smc.si	office@smc.si
<b>Spain</b>	+34 945184100	www.smc.eu	post@smc.smces.es
<b>Sweden</b>	+46 (0)86031240	www.smc.nu	smc@smc.nu
<b>Switzerland</b>	+41 (0)523963131	www.smc.ch	info@smc.ch
<b>Turkey</b>	+90 212 489 0 440	www.smcturkey.com.tr	info@smcturkey.com.tr
<b>UK</b>	+44 (0)845 121 5122	www.smc.uk	sales@smc.uk

**South Africa** +27 10 900 1233    www.smcza.co.za    zasales@smcza.co.za