

# Fieldbus System (Gateway Decentralised Type)



GW Unit which supports PROFINET added.  
M12 connector type Input Unit added.

## Decentralised valve installation

**Valves can be installed near the actuators!**

GW Unit (Gateway Unit)



- Reduced piping space and piping materials
- Reduced wiring space
- No need to set the address for the valve manifold and Input Unit.

Description	Compatible protocol	Number of inputs/outputs	Number of valve manifold and Input Unit connections	Branch cable length	New function
Gateway Decentralised System 2 <a href="#">Page 8</a>	 EtherNet/IP	128 inputs/ 128 outputs	Max. 16 Units	Max. 20 m	<b>Web server function</b> <ul style="list-style-type: none"> <li>Valve operation test</li> <li>Connection diagnostic</li> <li>Short-circuit diagnostic</li> </ul> <a href="#">Page 2</a>

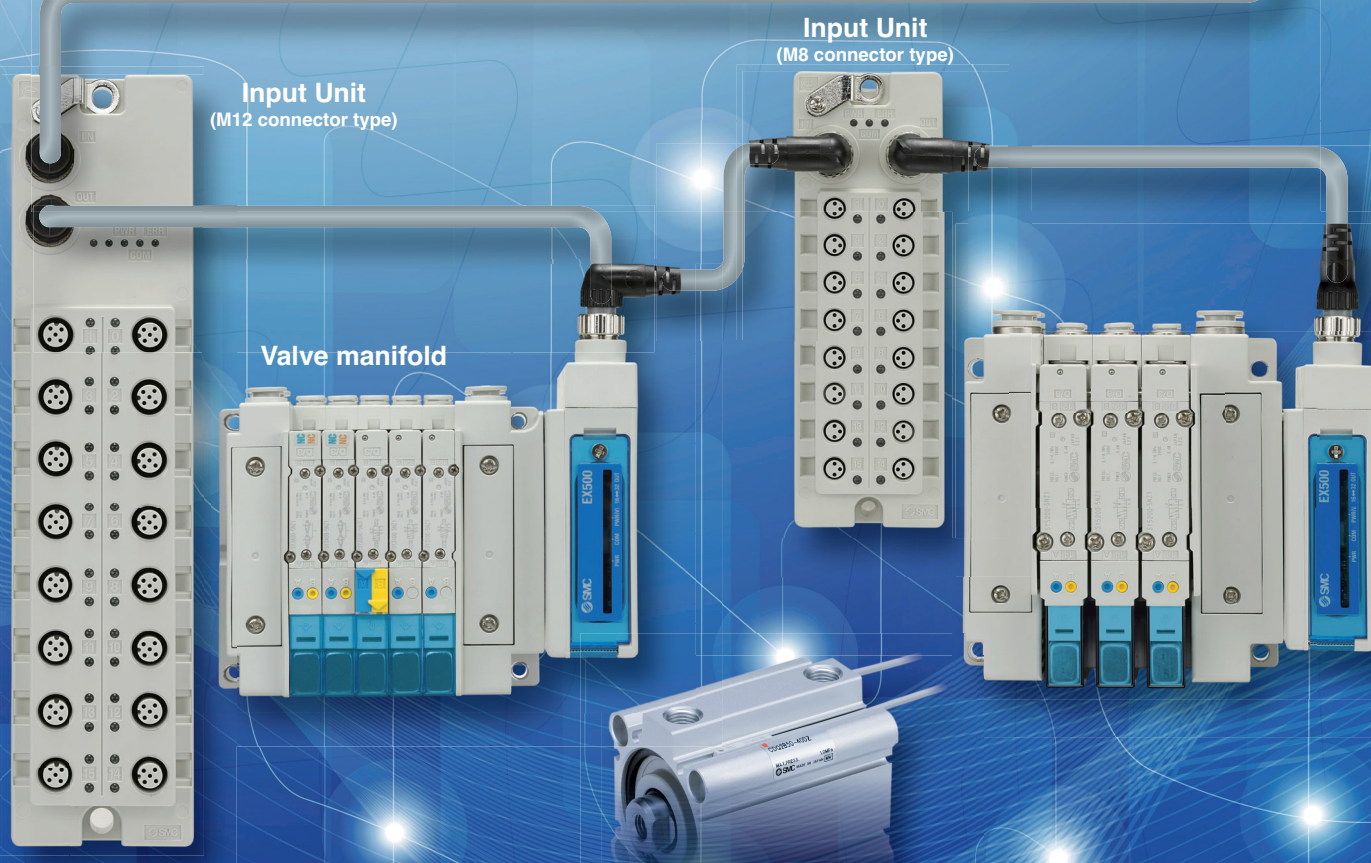

Series EX500



CAT.EU02-26Aa-UK

## Gateway Decentralised System 2 (128 Points)

● Number of branch ports: 4

Number of inputs/outputs **128** inputs/**128** outputs

● Number of inputs/outputs per branch: Max. 32 inputs/32 outputs

Number of valve manifold connections **Max. 8 Units\***      Number of Input Unit connections **Max. 8 Units**

● Number of valve manifold connections per branch: Max. 2 Units\*      ● Number of Input Unit connections per branch: Max. 2 Units

Total cable length per branch **Max. 20 m**

\* When the number of outputs is set to "16 outputs" using a built-in setting switch of the SI Unit.

Maximum number of inputs: **128** points      Maximum number of outputs: **128** points

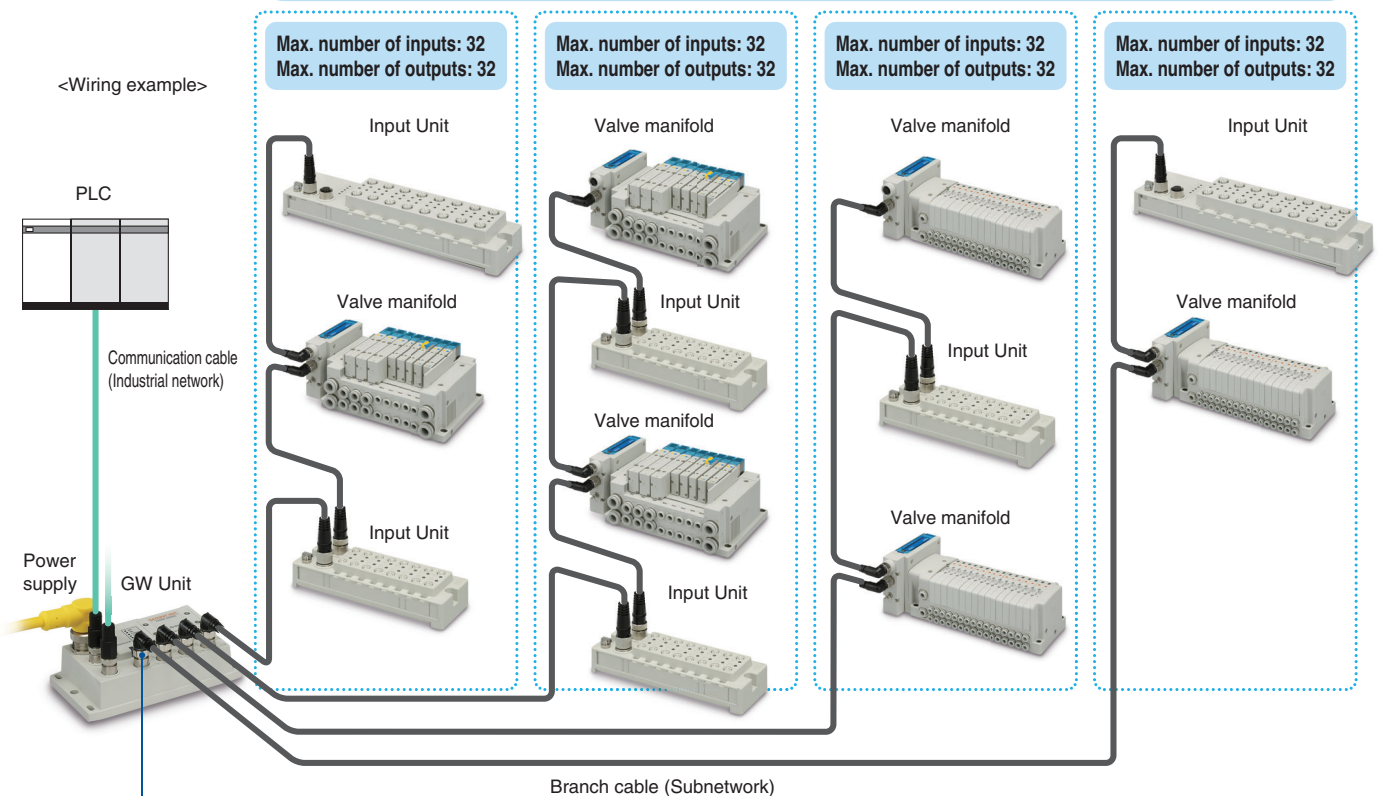

Branch port

### Two valve manifolds can be connected to one branch port.

SI Unit has a built-in setting switch which switches the number of outputs (32 points / 16 points) of the valve manifold connected to the SI Unit. By setting the number of outputs to 16 points, two valve manifolds can be installed to one branch port.

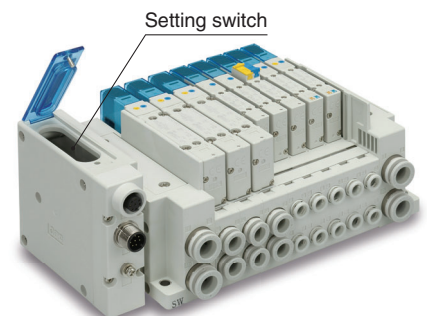

SI Unit



## Web server function

Valve operation test (ON/OFF), connection diagnostic between valve manifold and Input Unit, and short-circuit diagnostic of input device can be performed on a Web browser.

A password can be used for the valve operation test (ON/OFF) for security.

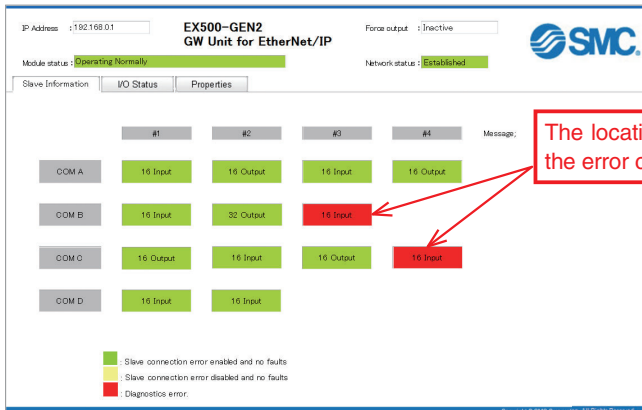

The location of the error can be identified. Details of the error can be identified on a Web browser.

Green LED flashing  
These ports are in error.

Red LED ON



\* WEB display example



RJ-45 connector

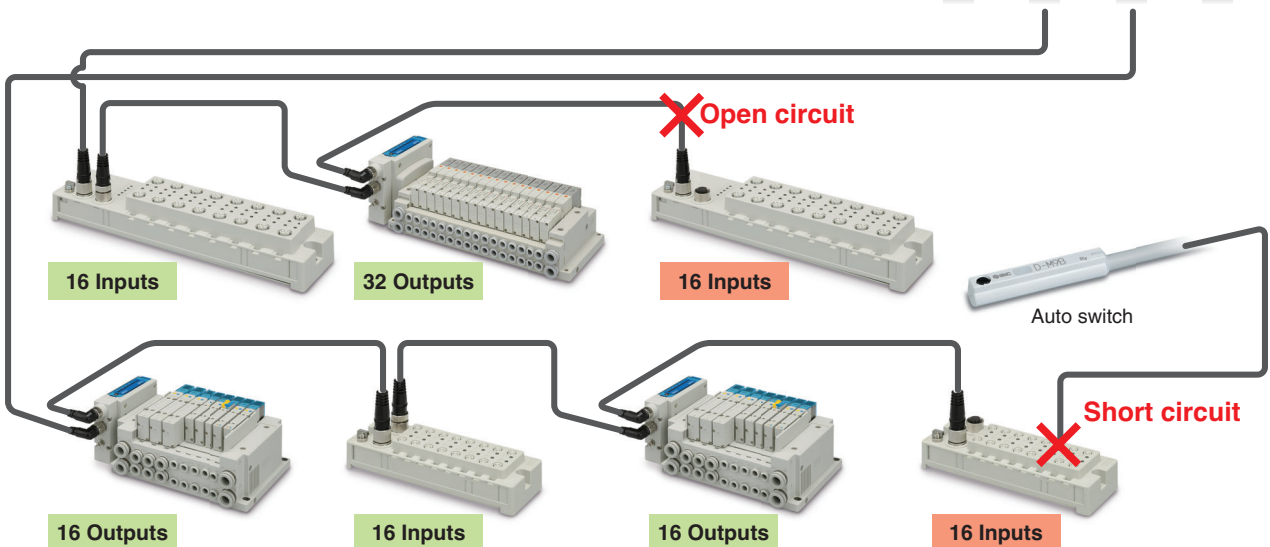
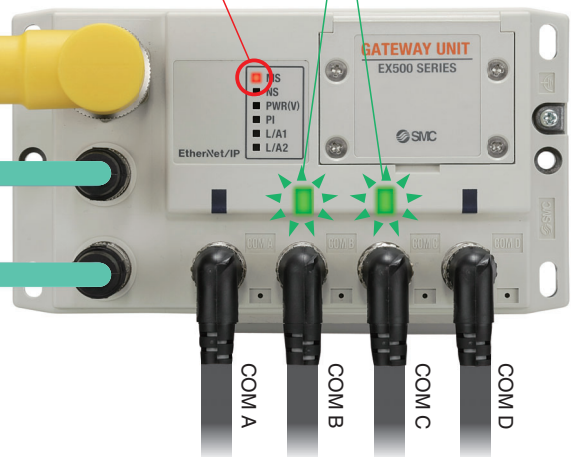

## No need to set the address

I/O mapping for the SI Unit and Input Unit is set by the Gateway Unit automatically.

The Unit installation order is not specified.

(The upper limit of the inputs / outputs is 32 points for one branch port.)

# Gateway Decentralised System 2 (128 Points)

## Reduced wiring

The amount of communication and power supply wiring for the I/O device can be reduced.

## Reduction of number of communication nodes

By reducing the number of communication nodes, the load on the network is reduced.

## Accessories can be ordered together. Page 13

Accessories including cables and connectors can be ordered together to SMC. Time for selecting parts, ordering and managing lead time can be reduced.



## Flexibly copes with changes in the protocol.

Previously, it was necessary to change the part number of the I/O unit, return the I/O unit, and make arrangements once again to obtain a new unit (additional quotation, delivery period control).



Only the GW Unit needs to be changed.

## Applicable to output devices other than valve manifold. Page 16

By using output block, lights and buzzers can be operated.

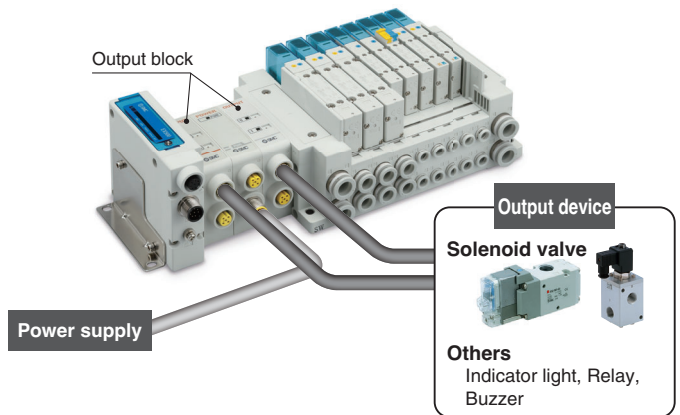

## Specified valve manifold can be controlled by supplying power from a different system. Page 15

By using a Y branch connector, power from a different system can be supplied to the SI Unit (valve manifold).

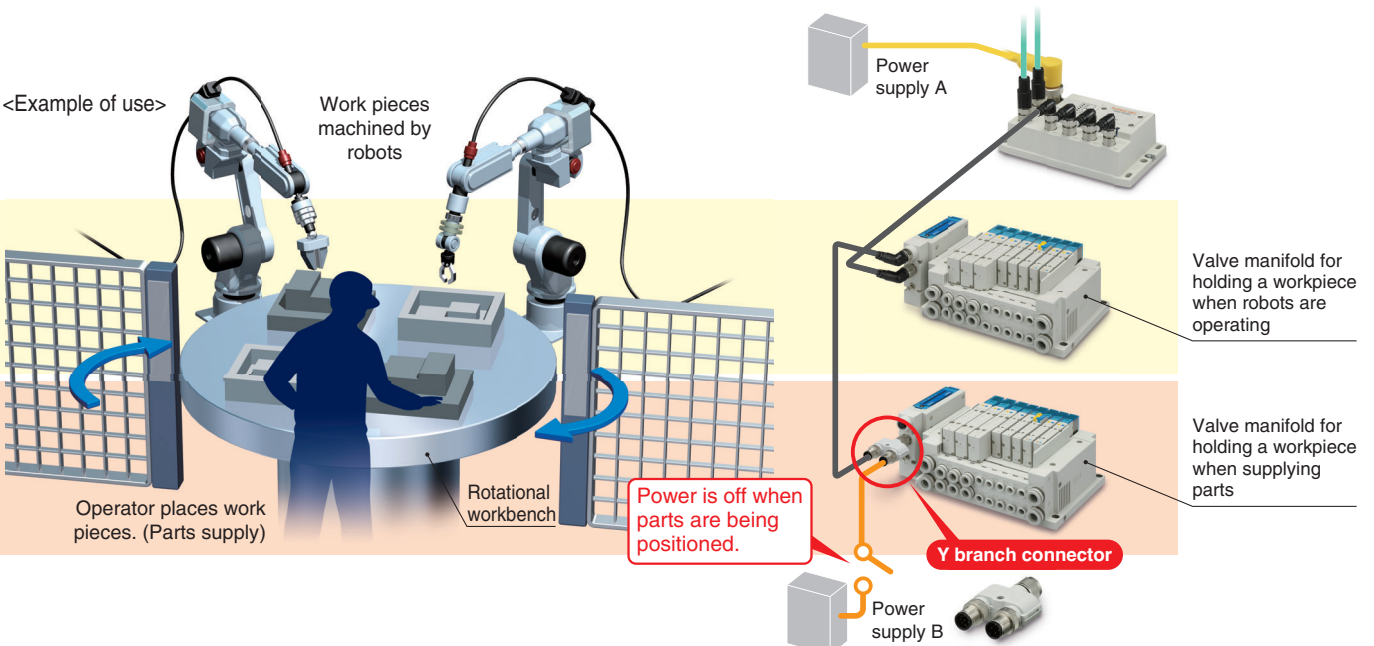









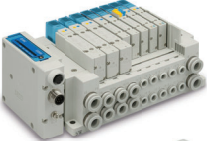



## System Comparison Table

Gateway Decentralised System 2	
Protocol	 EtherNet/IP <sup>®</sup>
Number of inputs/outputs (Number of inputs/outputs per branch)	128 inputs/128 outputs (32 inputs/32 outputs)
Number of valve manifold connections (Number of connections per branch)	Max. 8 Units* (Max. 2 Units)
Number of Input Unit connections (Number of connections per branch)	Max. 8 Units (Max. 2 Units)
Branch cable length	Max. 20 m
Enclosure	GW Unit: IP65 SI Unit: IP67 Input Unit: IP67
Function	Web server function (Valve operation test, Connection diagnostic, Short-circuit diagnostic)
Page	8

\* When the number of outputs is set to "16 outputs" using a built-in setting switch of the SI Unit.

## Applicable Valve Series

Series	Flow rate characteristics (4/2→5/3)			Maximum number of solenoids	Power consumption [W]	Enclosure	International standard	Page	
	C [dm <sup>3</sup> /(s·bar)]	b	Q [l/min (ANR)] <small>Note 2)</small>						
	SY3000	1.6	0.19	381	32	0.35 (Standard) 0.1 (With power saving circuit) [Inrush 0.4, Holding 0.1]			19
	SY5000	3.6	0.17	848					
	SY7000	5.9	0.20	1413					
	VQC1000	1.0 <small>Note 1)</small>	0.30 <small>Note 1)</small>	254	24	0.4 (Standard)  0.95 (Standard) 0.4 (Low-wattage type)			27
	VQC2000	3.2 <small>Note 1)</small>	0.30 <small>Note 1)</small>	814					
	VQC4000	7.3 <small>Note 1)</small>	0.38 <small>Note 1)</small>	1958					
	VQC5000	17.0 <small>Note 1)</small>	0.31 <small>Note 1)</small>	4350					
	S0700	0.37	0.39	100	32	0.35			39
	SV1000	1.1	0.35	289	32	0.6			42
	SV2000	2.4	0.18	568					
	SV3000	4.3	0.21	1036					

Note 1) Values for 2-position single, rubber seal type

Note 2) These values have been calculated according to ISO 6358 and indicate the flow rate under standard conditions with an inlet pressure of 0.6 MPa (relative pressure) and a pressure drop of 0.1 MPa.

# Series SY3000/5000/7000

Piping on the top or the bottom makes the footprint smaller to realise dramatic space-saving.

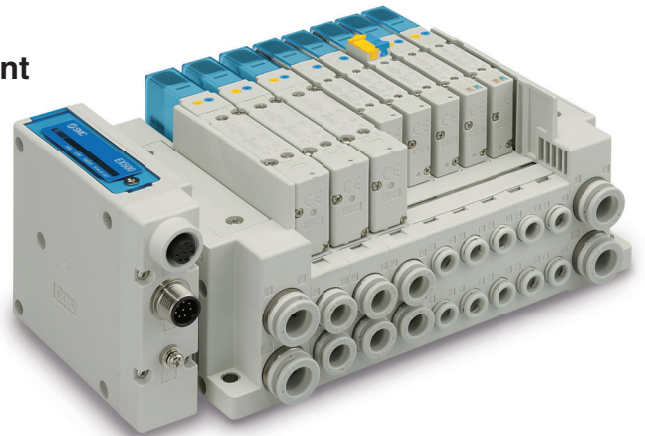

## Valve piping direction variations

Piping is possible from 3 directions.

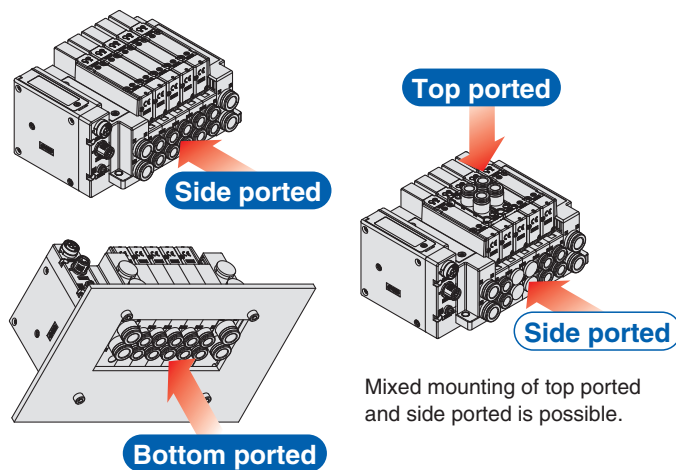

## Max. 24 stations connectable

It is possible to connect only the number of valves required, from 1 to 24 stations, to suit the application. (Maximum number of solenoids: 32)

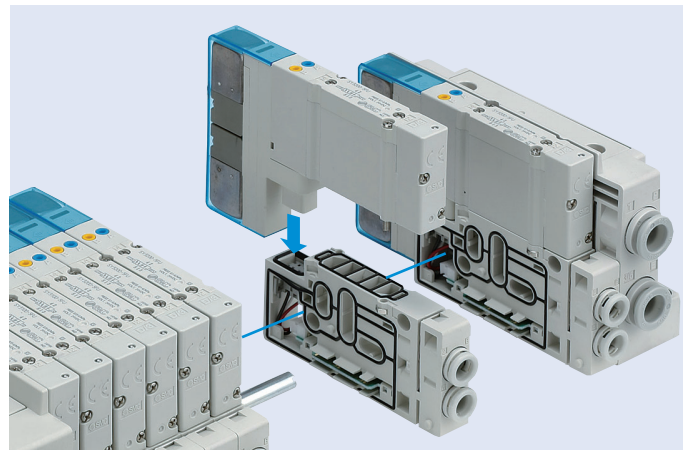

## Mixed valve sizes manifold

It is also possible to install a combination of different-sized valves on the same manifold. (SY3000 and SY5000, or SY5000 and SY7000)

This facilitates reduction in the installation space and number of units/cables.

Example: For SY5000 and SY3000

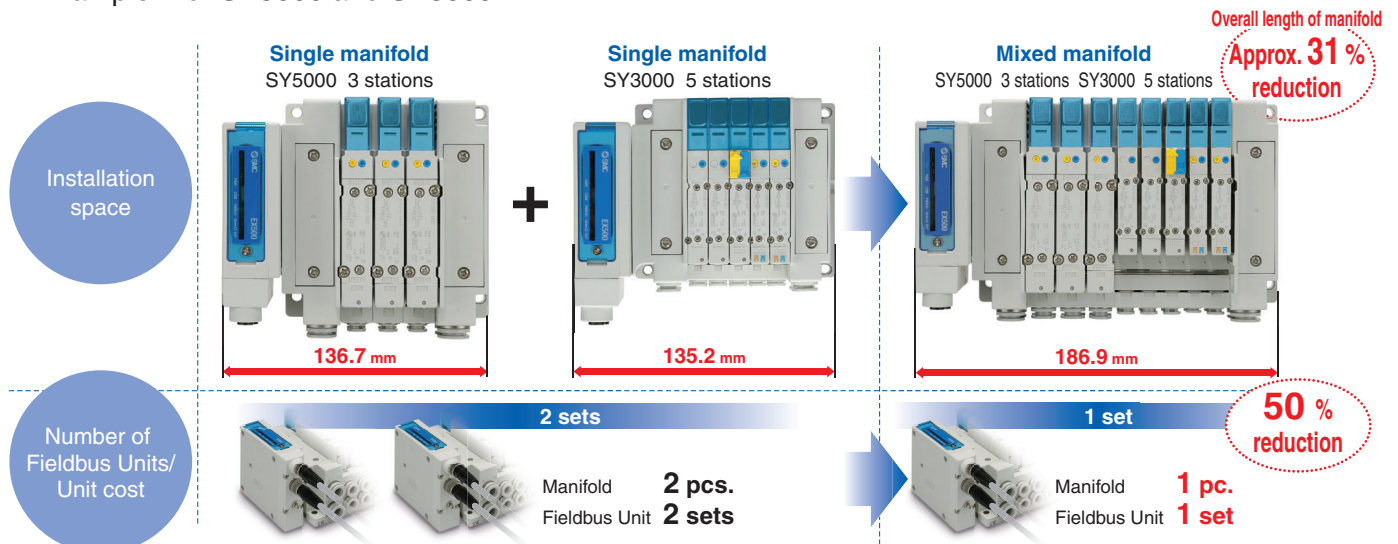

# CONTENTS

## Fieldbus System (Gateway Decentralised Type) Series EX500

■ Features (Gateway Decentralised System 2) .....	Page 1
■ System Comparison Table/Applicable Valve Series .....	Page 4
■ Introduction of the SY Series Valve .....	Page 5

### Series EX500 Gateway Decentralised System 2 (128 Points) Page 8

■ GW Unit	
How to Order .....	Page 9
Specifications .....	Page 9
Dimensions/Parts Description .....	Page 10
■ SI Unit	
How to Order .....	Page 11
Specifications .....	Page 11
Dimensions/Parts Description .....	Page 11
■ Input Unit	
How to Order .....	Page 12
Specifications .....	Page 12
Dimensions/Parts Description .....	Page 12
■ Accessories	
• Power Supply Cable • Communication Cable/Connector .....	Page 13
• Branch Cable • Y Branch Connector • Cable for Power Supply from a Different System .....	Page 15
• Marker • Seal Cap • DIN Rail Bracket .....	Page 15
• Output Block .....	Page 16
• Power Block .....	Page 16
• Connector for Output Block Wiring • Power Supply Cable for Power Block .....	Page 17
• End Plate • Bracket Plate .....	Page 18
■ SY3000/5000/7000	
How to Order: Type 10/Type 11 .....	Page 19
Type 12 .....	Page 22
Dimensions: Type 10 SY3000 .....	Page 24
SY5000 .....	Page 25
SY7000 .....	Page 26
For dimensions of Type 11 and Type 12, refer to the SY series catalogue (CAT. EUS11-103).	
■ VQC1000	
How to Order .....	Page 27
Dimensions .....	Page 29
■ VQC2000	
How to Order .....	Page 30
Dimensions .....	Page 32
■ VQC4000	
How to Order .....	Page 33
Dimensions .....	Page 35
■ VQC5000	
How to Order .....	Page 36
Dimensions .....	Page 38
■ S0700	
How to Order .....	Page 39
Dimensions .....	Page 41
■ SV1000/2000/3000	
How to Order .....	Page 42
Dimensions: Tie-rod Base SV1000 .....	Page 44
SV2000 .....	Page 45
SV3000 .....	Page 46
■ Precautions on Mixed Usage of Gateway Decentralised System 2 and Gateway Decentralised System .....	Page 47

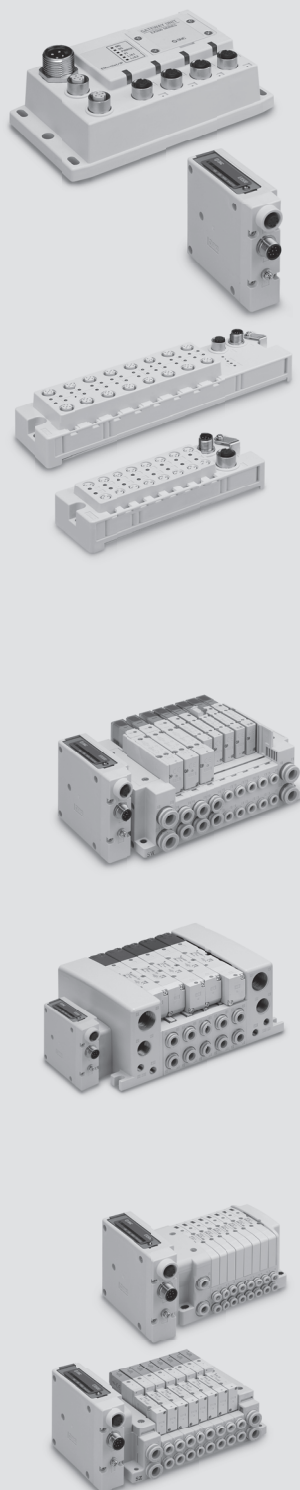

# CONTENTS

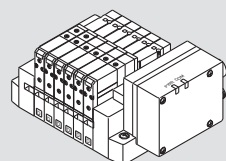
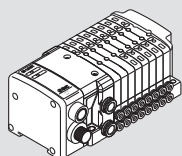
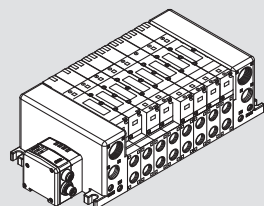
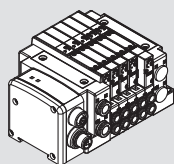

## Series EX500 Gateway Decentralised System (64 Points) **Page 48**

■ SY3000/5000/7000	
How to Order: Type 10/Type 11 .....	Page 47
Type 12 .....	Page 50
Dimensions: Type 10 SY3000 .....	Page 52
SY5000 .....	Page 53
SY7000 .....	Page 54
	For dimensions of Type 11 and Type 12, refer to the SY series catalogue (CAT. EUS11-103).
■ VQC1000	
How to Order .....	Page 55
Dimensions .....	Page 57
■ VQC2000	
How to Order .....	Page 58
Dimensions .....	Page 60
■ VQC4000	
How to Order .....	Page 61
Dimensions .....	Page 63
■ VQC5000	
How to Order .....	Page 64
Dimensions .....	Page 66
■ S0700	
How to Order .....	Page 67
Dimensions .....	Page 69
■ SV1000/2000/3000/4000	
How to Order .....	Page 70
Dimensions: Cassette Base	SV1000 .....
	SV2000 .....
	SV3000 .....
	SV4000 .....
Tie-rod Base	SV1000 .....
	SV2000 .....
	SV3000 .....
	SV4000 .....



# Fieldbus System Gateway Decentralised System 2 (128 Points) Series EX500



\* Only the SY and SV valves are UL-compliant.



- ★ Valve manifold and Input Unit can be connected around the GW (Gateway) Unit.
- ★ Number of inputs/outputs = 128 points/128 points. The number of outputs (solenoids) per branch is 32 points.
- ★ Number of valve manifold connections = Max. 8 Units, Number of Input Unit connections = Max. 8 Units, Branch cable length = Max. 20 m
- ★ Web server function (Valve operation test, connection diagnostic of Units, short-circuit diagnostic of input devices)
- ★ No need to set the address for the valve manifold and Input Unit.

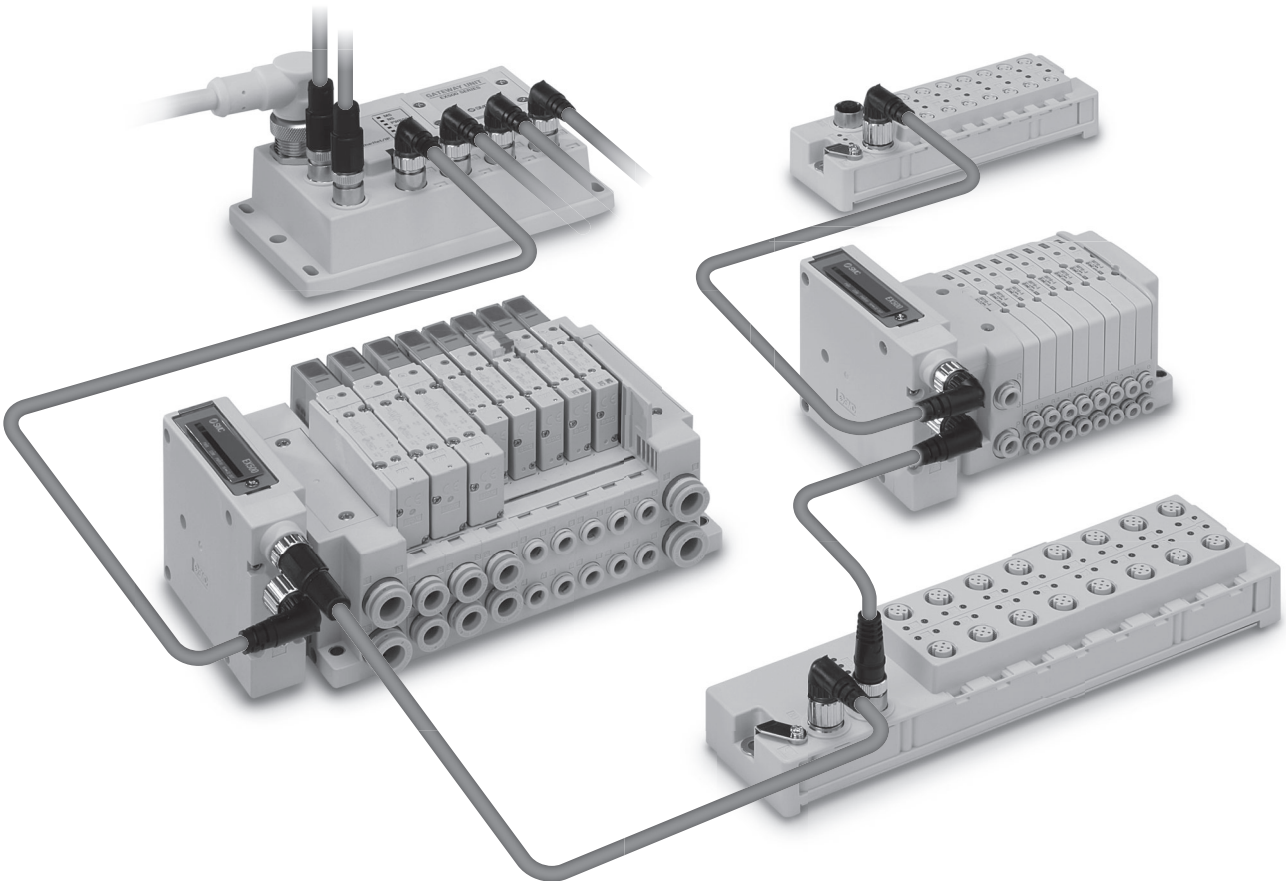

Gateway Decentralised System 2  
SY  
VQC  
S0700  
SV

**SY3000/5000/7000**

Page 19

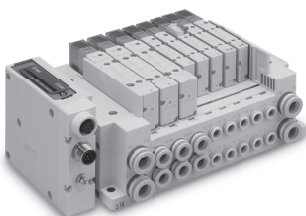

**VQC1000/2000/4000/5000**

Page 27

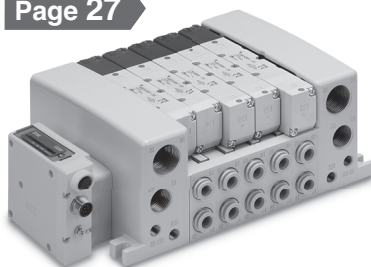

**S0700**

Page 39



**SV1000/2000/3000**

Page 42

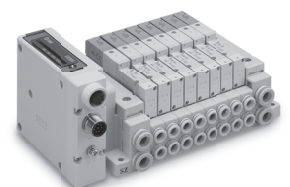

# Gateway Decentralised System 2 (128 Points) GW Unit



## How to Order

### EX500 – G EN2

#### Communication protocol

<b>EN2</b>	EtherNet/IP™ (Input/Output = 128 points/128 points)
<b>PN2</b>	PROFINET (Input/Output = 128 points/128 points)



## Specifications

Model		EX500-GEN2	EX500-GPN2
Communication	<b>Protocol</b>	EtherNet/IP™ Note 1)	PROFINET IO
	<b>Version</b> Note 2)	Volume 1 (Edition 3.14) Volume 2 (Edition 1.15)	PROFINET Specification Version 2.2
	<b>Media</b>	100BASE-TX	100BASE-TX
	<b>Communication speed</b>	10/100 Mbps (Automatic)	100 Mbps
	<b>Communication method</b>	Full duplex/Half duplex (Automatic)	Full duplex
	<b>Number of inputs/ outputs (I/O occupation area)</b>	128 inputs/128 outputs (20 bytes/20 bytes)	128 inputs/128 outputs (18 bytes/16 bytes)
	<b>Configuration file</b> Note 3)	EDS file	GSDML
	<b>IP address setting range</b>	Switch settings: 192.168.0.1 to 254 or 192.168.1.1 to 254, Through DHCP server: Optional address	Optional address
	<b>Device information</b>	Vendor ID: 7 (SMC Corporation) Product type: 12 (Communication Adapter), Product code: 198	—
<b>Applicable function</b>	DLR QuickConnect™ Web server	MRP Fast Start Up Web server	
Power supply voltage	<b>For input and control</b>	24 V DC ±10 %	
	<b>For valve</b>	24 V DC +10 %, -5 %	
Current consumption	<b>For input and control</b>	6.2 A or less (Max. 1.5 A per branch x 4 branches + GW Unit internal current consumption: 0.2 A or less)	
	<b>For output (valve)</b>	4 A or less (Max. 1 A per branch x 4 branches)	
Branch port	<b>Number of branch ports</b>	4 ports	
	<b>Number of inputs and outputs</b>	32 inputs/32 outputs per branch	
	<b>Branch cable length</b>	20 m or less per branch	
Environment	<b>Enclosure</b>	IP65	
	<b>Operating temperature range</b>	Operating: -10 to 50 °C, Stored: -20 to 60 °C (No condensation)	
	<b>Operating humidity range</b>	Operating, Stored: 35 to 85 %RH (No condensation)	
<b>Standards</b>	CE/UKCA marking (EMC directive/ RoHS directive), UL (CSA)		
<b>Weight</b>	550 g		
<b>Enclosed parts</b>	Seal cap (for M12 connector socket) 5 pcs.		

Note 1) Use a CAT5 or higher communication cable.

Note 2) Please note that the version is subject to change.

Note 3) Each file can be downloaded from SMC website, <http://www.smc.eu>

**Dimensions/Parts Description**

**EX500-GEN2 (EtherNet/IP™)**

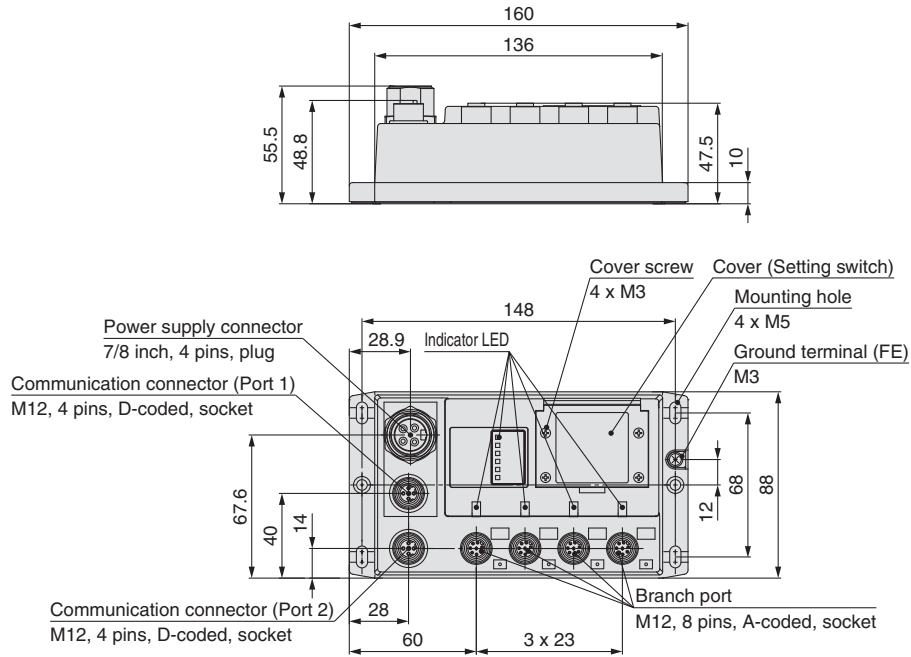

**EX500-GPN2 (PROFINET)**

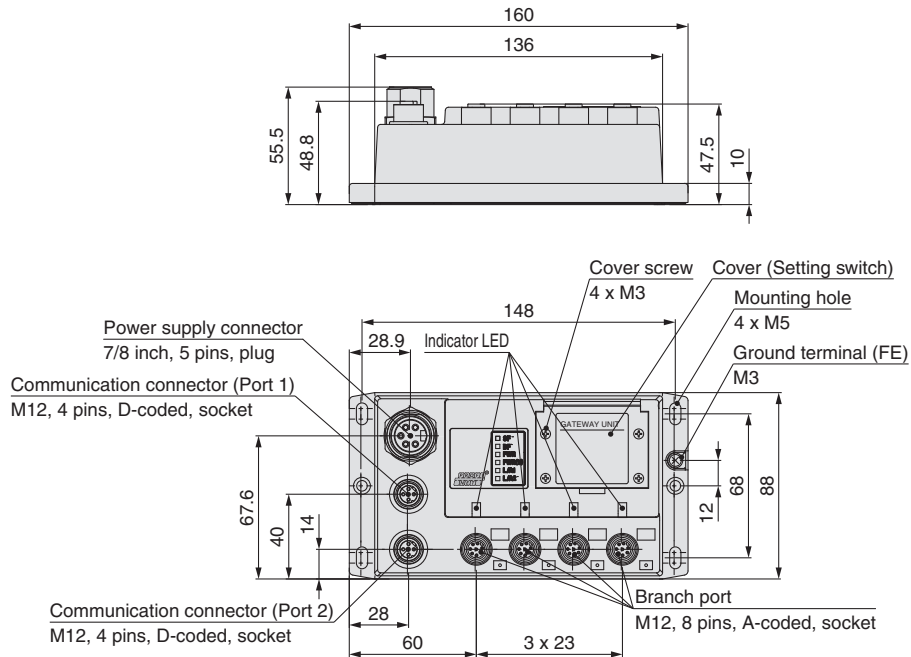

Gateway Decentralised System 2  
SY  
VQC  
S0700  
SV

Output Unit for valve manifold connection

### How to Order

## EX500 – S103



### Specifications

Model		EX500-S103
Applicable valve		SY, VQC, S0700, SV
Output	Number of outputs	16/32 outputs (Switched by built-in setting switch)
	Output type	Source/PNP (Negative common)
	Rated voltage	24 V DC
	Supply current	With power supplied to GW Unit: Max. 1.0 A With external power* supplied: Max. 1.5 A
Internal current consumption		50 mA or less
Environment	Enclosure	IP67
	Operating temperature range	Operating: -10 to 50 °C, Stored: -20 to 60 °C (No condensation)
	Operating humidity range	Operating, Stored: 35 to 85 % RH (No condensation)
Standards		CE/UKCA marking, UL (CSA), RoHS compliant
Weight		200 g
Enclosed parts		Seal cap (for M12 connector socket) 1 pc. Valve manifold mounting screw (M3 x 30) 2 pcs.

\* When an accessory, Y branch connector, is used.

### Dimensions/Parts Description

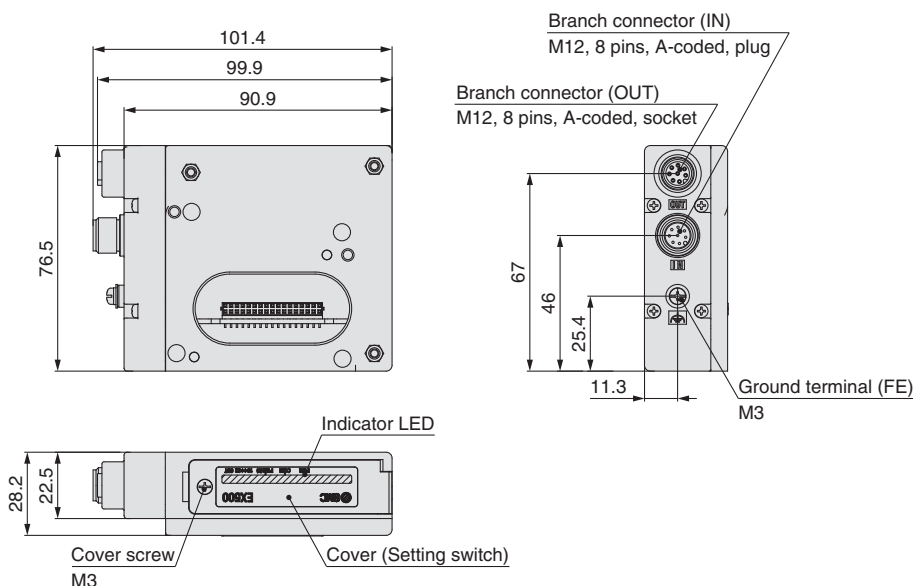

# Gateway Decentralised System 2 (128 Points) Input Unit

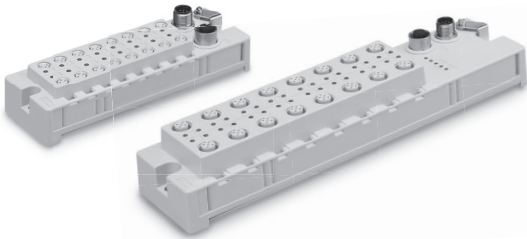

## How to Order

### EX500 — DX P A

Input unit

Connector type

A	M8 connector type
B	M12 connector type

## Specifications

Model	EX500-DXPA	EX500-DXPB
Connector type	M8 connector	M12 connector
Input	Number of inputs	16 inputs
	Input type	PNP
	Rated voltage	24 V DC
	Supply current	Max. 1.3 A/Unit [ Total of 8 connectors of even number must be Max. 0.65 A, 8 connectors of odd number must be Max. 0.65 A ]
	Input ON voltage/Input ON current	11 V or more/Typ. 7 mA (at 24 V DC)
	Input OFF voltage/Input OFF current	5 V or less/1.5 mA or less
Internal current consumption	200 mA or less (when the input signal is ON)	
Environment	Enclosure	IP67
	Operating temperature range	Operating: -10 to 50°C, Stored: -20 to 60 °C (No condensation)
	Operating humidity range	Operating, Stored: 35 to 85 %RH (No condensation)
Standards	CE/UKCA marking, UL (CSA), RoHS compliant	
Weight	250 g	450 g
Enclosed parts	Seal cap (for M8 connector socket) 16 pcs.	Seal cap (for M12 connector) 17 pcs.
	Seal cap (for M12 connector socket) 1 pc.	

## Dimensions/Parts Description

### EX500-DXPA

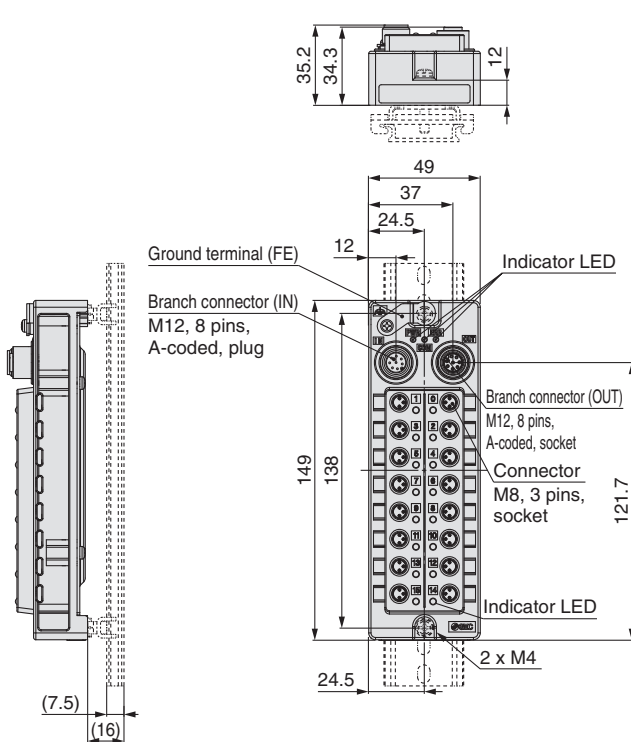

### EX500-DXPB

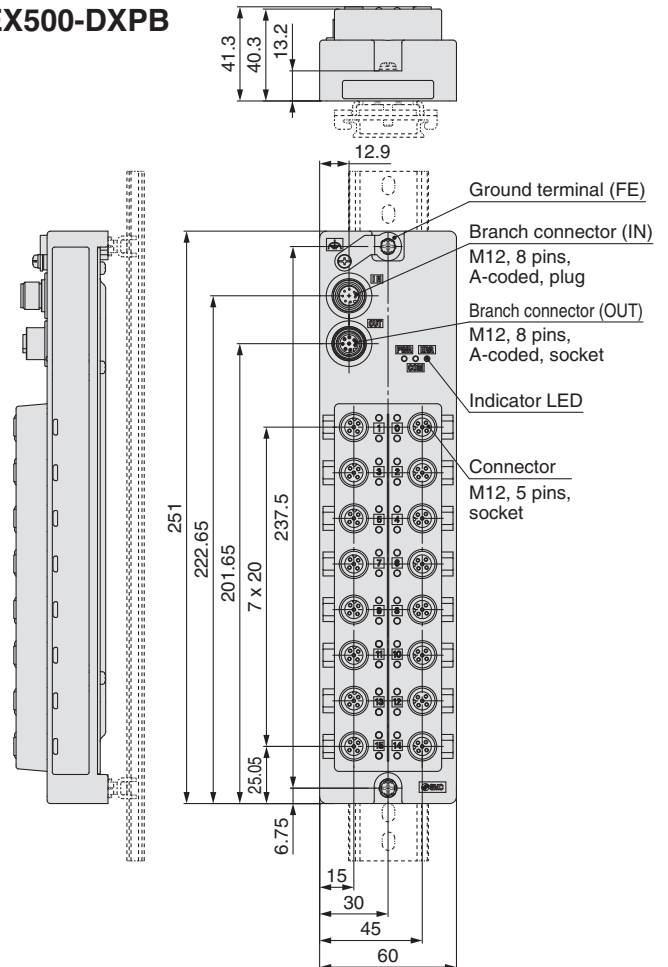

Gateway Decentralised System 2

SY

VQC

S0700

SV

# Gateway Decentralised System 2 (128 Points) Accessories

## ① Power Supply Cable

Supplies power to the GW Unit.

For EtherNet/IP™

### PCA-1416000

Connector specification, Cable length (L)

1415999	Straight 2 m
1415996	Straight 6 m
1416000	Angle 2 m
1415997	Angle 6 m

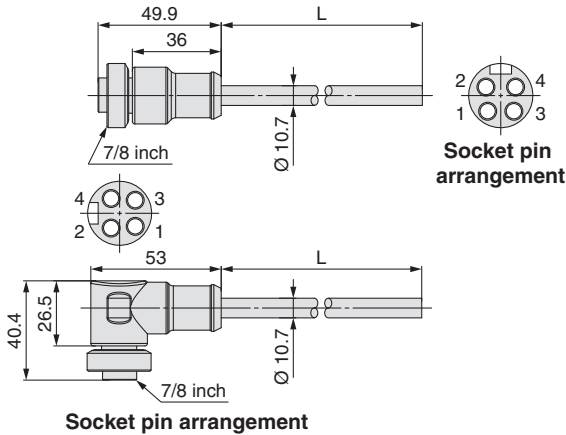

For PROFINET

### PCA-1558810

Connector specification, Cable length (L)

1558810	Straight 2 m
1558823	Straight 6 m
1558836	Angle 2 m
1558849	Angle 6 m

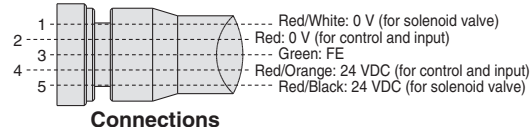
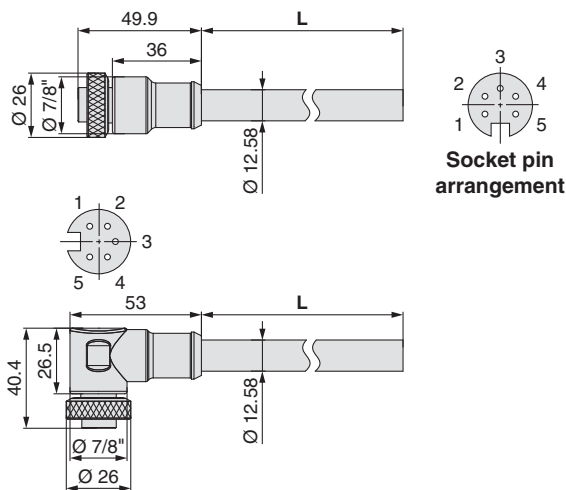

## ② Communication Cable/Connector

Connects Fieldbus to the GW Unit.

For PROFINET

For EtherNet/IP™

Cable with connector

### PCA-1446566

SPEEDCON

Cable length

1446566	5000 [mm]
---------	-----------

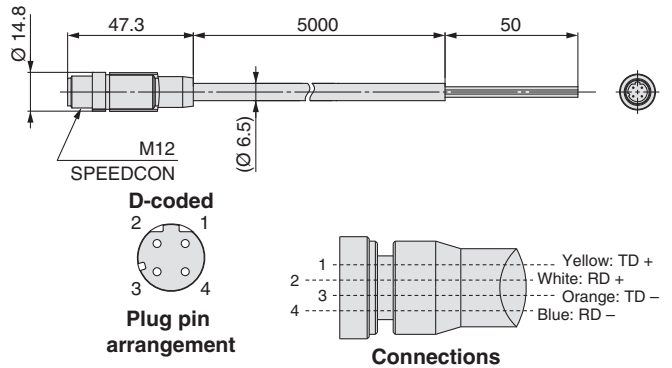

Field wireable connector

### PCA-1446553

D-coded

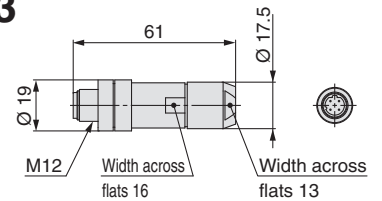
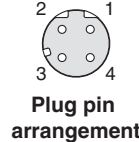

Applicable Cable

Cable O.D.	4.0 to 8.0 mm
Wire gauge (Stranded wire cross section)	0.14 to 0.34 mm <sup>2</sup> /AWG26 to 22

Note) The table above shows the specifications for the applicable cable. Adaptation for the connector may vary on account of the conductor construction of the electric wire.

## EX9-AC 020 EN-PSRJ

Cable length (L)

010	1000 [mm]
020	2000 [mm]
030	3000 [mm]
050	5000 [mm]
100	10000 [mm]

Connector specification

PSRJ	M12 plug (Straight) ⇔ RJ-45 connector
------	--

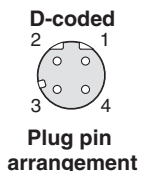
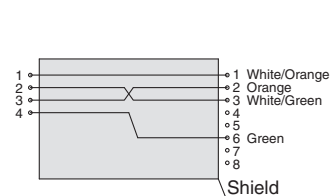
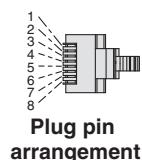
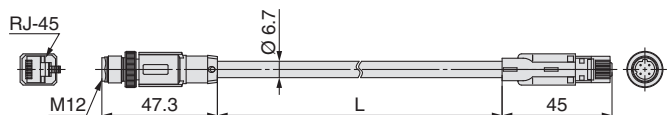

② Communication Cable/Connector

For PROFINET

For EtherNet/IP™

(With angle connector on both sides (Plug/Plug))

**EX9-AC 005 EN-PAPA**

● Cable length (L)

005	500 mm
010	1000 mm
020	2000 mm
030	3000 mm
050	5000 mm
100	10000 mm

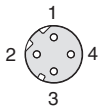
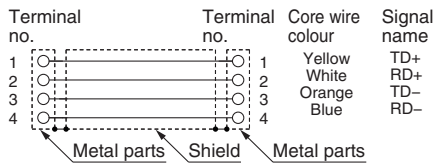
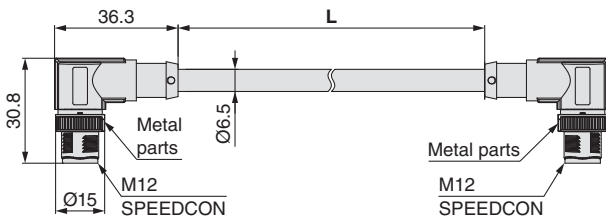

Plug connector pin arrangement D-coded

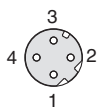

Plug connector pin arrangement D-coded

Connections (Straight cable)

Item	Specifications
Cable O.D.	Ø 6.5 mm
Conductor nominal cross section	0.34 mm <sup>2</sup> /AWG22
Wire O.D.(including insulator)	1.55 mm
Min. bending radius (Fixed)	19.5 mm

<Example of use>

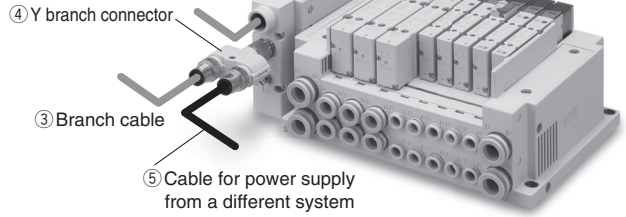

③ Branch Cable

Connects the GW Unit and SI Unit or Input Unit.

**EX500-AC 030 - SSPS**

● Cable length (L)

003	300 [mm]
005	500 [mm]
010	1000 [mm]
030	3000 [mm]
050	5000 [mm]
100	10000 [mm]

● Connector specification

SSPS	Socket side: Straight, Plug side: Straight
SAPA	Socket side: Angle, Plug side: Angle

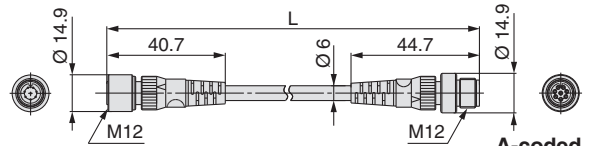

A-coded



Plug

A-coded



Socket

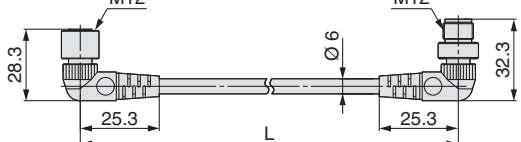

A-coded



Plug

A-coded



Socket

# Series EX500

## ④ Y Branch Connector

Supplies separate power to valve manifold when it is connected to the SI Unit.

### EX500-ACY01-S

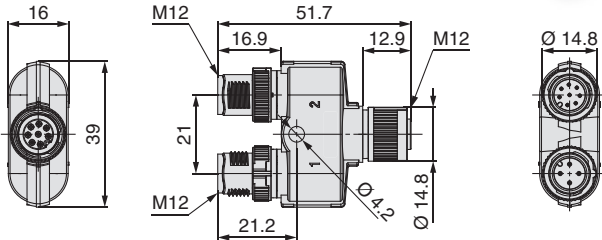

#### Pin Layout of the Cable for Power Supply from a Different System

1	24 V DC +10 %, -5 % (for solenoid valve)
2	0 V DC (for solenoid valve)
3	Unused
4	Unused

A-coded

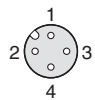

Plug pin arrangement

## ⑤ Cable for Power Supply from a Different System

Connect to Y branch connector to supply power.

### EX500-AP050-S

Cable length (L)

010	1000 [mm]
050	5000 [mm]

Connector specification

S	Straight
A	Angle

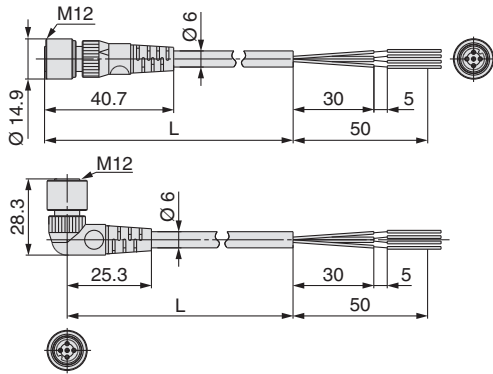

### PCA-1401804

Cable length (L)

1401804	1500 [mm]
1401805	3000 [mm]
1401806	5000 [mm]

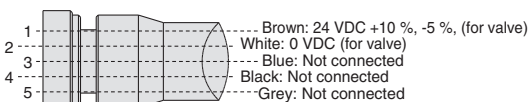
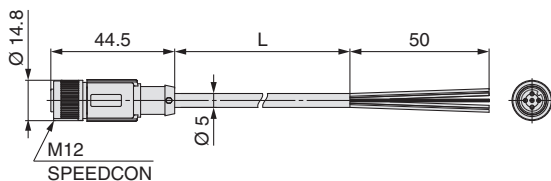

Connections

A-coded

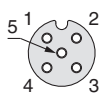

Socket pin arrangement

## ⑥ Marker (1 sheet, 88 pcs.)

Signal name of the input device such as a switch can be written on the marker and installed to the Input Unit.

### EX600-ZT1

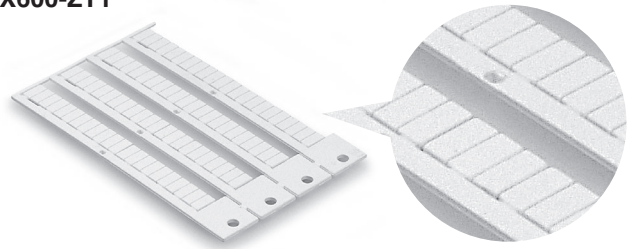

## ⑦ Seal Cap (10 pcs.)

Use with new connector. By using these waterproof caps, the new connector maintains IP65/67 enclosure.

### EX9-AWES

For M8 connector socket

### EX9-AWTS

For M12 connector socket



## ⑧ DIN Rail Bracket (2 pcs.)

Bracket for mounting the Input Unit (EX500-DXPA, EX500-DXPB) to DIN rail.

### EX500-ZMA1

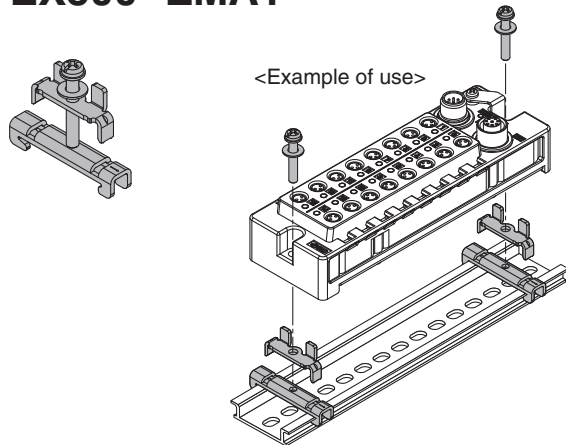



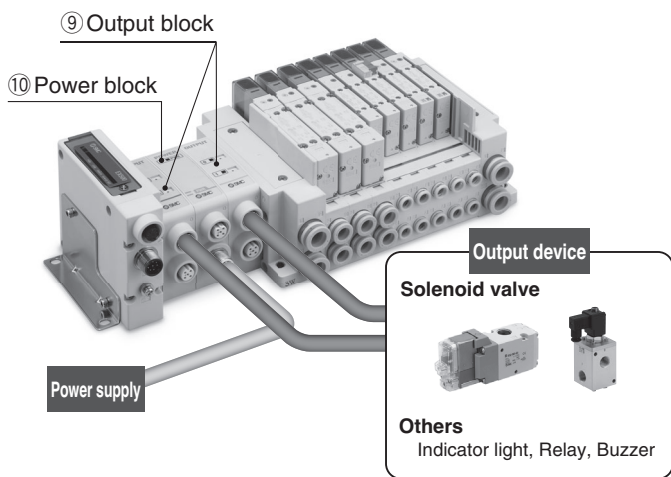

- Output devices other than valve manifold can be operated.
- By using the power block and output block for high watt load, operation up to 0.5 A/1 point can be performed.
- Possible to mount the output block and power block additionally between the SI Unit and the valve (The surplus I/O points are used).
- 2 point outputs per output block (M12 connector)

You are requested to connect it to an SI Unit and a valve manifold. For detailed specifications, refer to the Operation Manual that can be downloaded from SMC website, <http://www.smc.eu>

### ⑨ Output Block

#### EX9 – OET 1

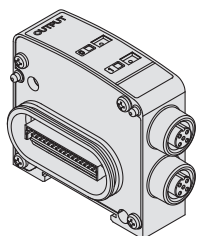

● Output specification

1	Source/PNP (Negative common)
---	------------------------------

● Power supply type

T	Internal power supply method (for low-wattage load)
P	Integrated power supply method (for high-wattage load) <small>Note)</small>

Note) Required to connect with a power block.

#### Dimensions/Parts Description

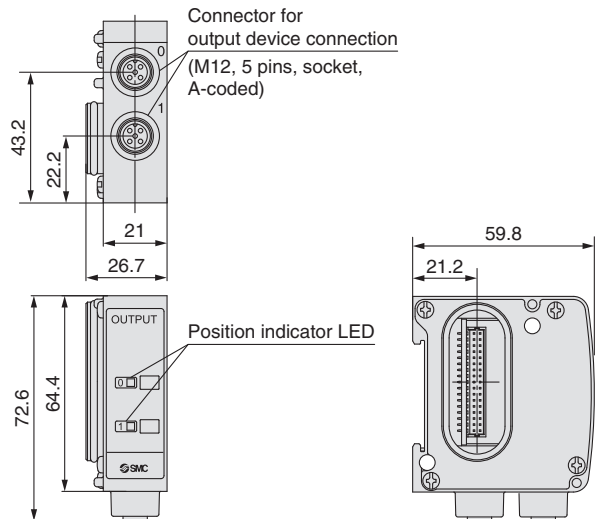

### ⑩ Power Block

#### EX9 – PE1

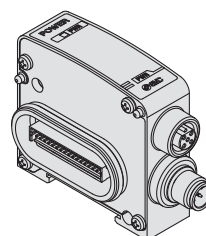

#### Dimensions/Parts Description

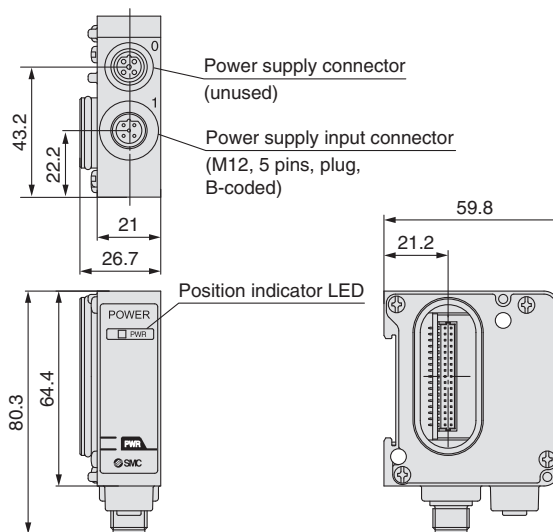

#### Specifications

Model	EX9-OET1	EX9-OEP1	
Internal current consumption	40 mA or less		
Output	Output type	Source/PNP (Negative common)	
	Number of outputs	2 outputs	
	Power supply method	Internal power supply method   Integrated power supply method (Power block: supplied from EX9-PE1)	
	Output device supply voltage	24 V DC	
	Output device supply current	Max. 42 mA/point (1.0 W/point)   Max. 0.5 A/point (12 W/point)	
Environment	Enclosure	IP67	
	Operating temperature range	-10 to 50 °C	
	Operating humidity range	35 to 85 %RH (No condensation)	
Standards	CE/UKCA marking, UL (CSA), RoHS compliant		
Weight	120 g		

#### Specifications

Model	EX9-PE1	
Connection block	Output block for high wattage load	
Connection block stations	Output block: Max. 8 stations	
Power supply for output and internal control	Power supply voltage	22.8 to 26.4 V DC
	Internal current consumption	20 mA or less
Supply current	Max. 3.1 A <small>Note)</small>	
Environment	Enclosure	IP67
	Operating temperature range	-10 to 50 °C
	Operating humidity range	35 to 85 %RH (No condensation)
Standards	CE/UKCA marking, UL (CSA), RoHS compliant	
Weight	120 g	
Enclosed parts	Seal cap (for M12 connector) 1 pc.	

Note) When using with 3.0 to 3.1 A, the ambient temperature should not exceed 40 °C, and do not bundle the cable.

# Series EX500

## ⑪ Connector for Output Block Wiring

Field wireable connects the output device to the output block.

### PCA-1557743

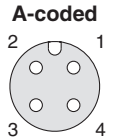
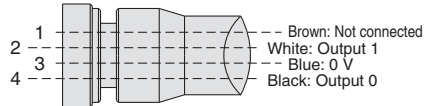
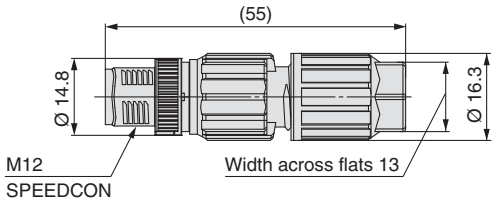

#### Applicable Cable

Cable O.D.	3.5 to 6.0 mm
Wire gauge (Stranded wire cross section)	0.14 to 0.34 mm <sup>2</sup> /AWG26 to 22
Core wire diameter (Including insulating material)	0.7 to 1.3 mm

### PCA-1557756

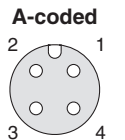
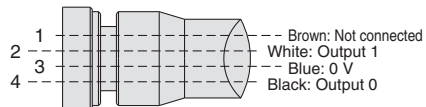
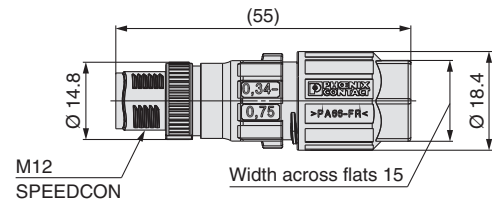

#### Applicable Cable

Cable O.D.	4.0 to 8.0 mm
Wire gauge (Stranded wire cross section)	0.34 to 0.75 mm <sup>2</sup> /AWG22 to 18
Core wire diameter (Including insulating material)	1.3 to 2.5 mm

## ⑫ Power Supply Cable for Power Block

Supplies power to the power block.

### EX9-AC 050-1

#### Cable length (L)

010	1000 [mm]
030	3000 [mm]
050	5000 [mm]

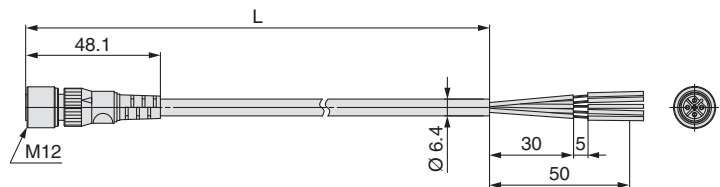

### PCA-1401807

#### Cable length (L)

1401807	1500 [mm]
1401808	3000 [mm]
1401809	5000 [mm]

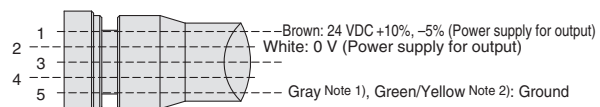
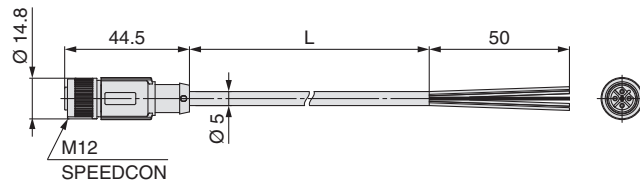

Note 1) For EX9-AC□-1  
Note 2) For PCA-□

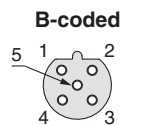

⑬ End Plate

Use when the output block is not used and the valve manifold is not connected.

EX9 – EA03

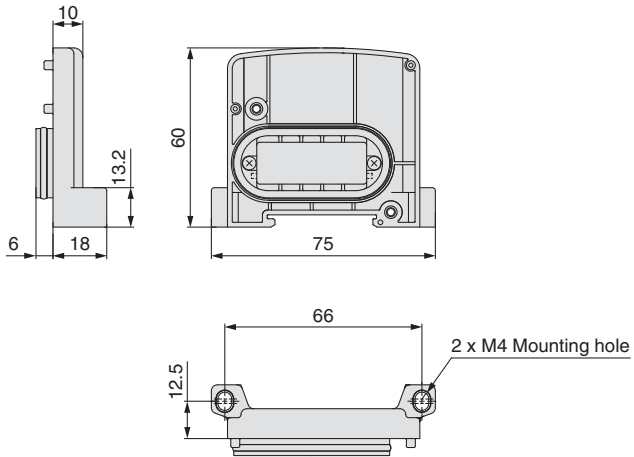

<Example of use>



⑭ Bracket Plate

A reinforcing brace used to mount output block or power block onto the SI Unit. To prevent connection failure between products due to deflection, use this bracket plate whenever output block or power block is mounted.

EX9 – BP1

Dimensions

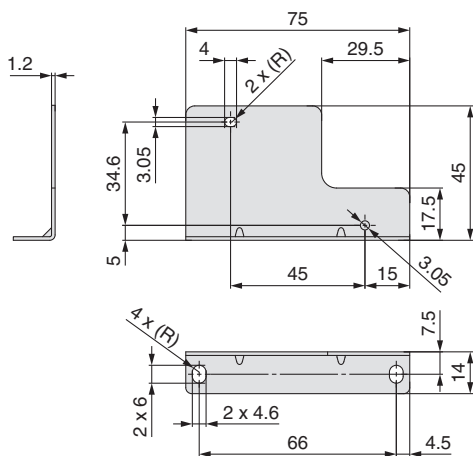

<Example of use>

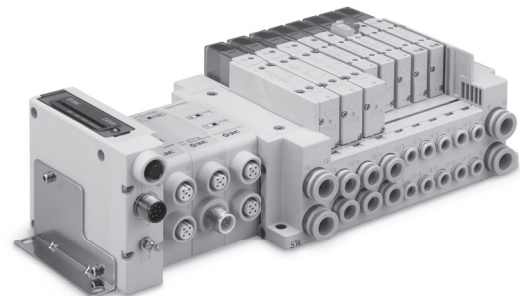

Accessory

Description	Quantity
Hexagon socket head cap screw (M3 x 35)	2

Type 10  
Side Ported

Type 11  
Bottom Ported

# Gateway Decentralised System 2

## 5 Port Solenoid Valve

### Series SY3000/5000/7000



For detailed specifications, Common Precautions and Specific Product Precautions, refer to the **WEB catalogue** or the SY series catalogue (CAT. EUS11-103).

### How to Order Manifold

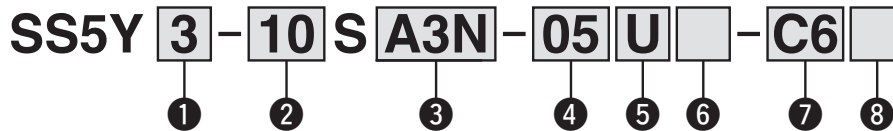

#### 1 Series

3	SY3000
5	SY5000
7	SY7000

\* For mixed mounting, refer to the **WEB catalogue** or the SY series catalogue (CAT. EUS11-103).

#### 2 Type

10	Side ported
11	Bottom ported <sup>Note)</sup>

Note) The SY5000 manifold base is used for the bottom ported of the SY3000. When ordering, refer to the **WEB catalogue** or the SY series catalogue (CAT. EUS11-103).

\* When mixing top ported configurations, select from page 23.  
In this case, use caution as there is also output on the A and B port on base side. Specify on a manifold specification sheet if plugs are required on the A and B port on base side.

#### 3 SI Unit (Number of outputs, Output polarity, Max. number of valve stations)

0	Without SI Unit
A3N	32 outputs <sup>Note 1, 4)</sup> , 1 to 16 stations (24 stations <sup>Note 3)</sup> ), Negative common <sup>Note 2)</sup>

Note 1) 16 outputs can be set by switching the built-in setting switch.  
Note 2) Ensure a match with the common specification of the valve.  
Note 3) ( ): Maximum number of stations for mixed single and double wiring.  
Note 4) When using the SI Unit with 32 outputs, use the GW Unit compatible with the EX500 Gateway Decentralised System 2 (128 points).

#### 4 Valve stations

Stations	Note
02	2 stations Double wiring <sup>Note 1)</sup>
⋮	
16	16 stations Mixed wiring, Specified layout <sup>Note 2)</sup> (Available up to 32 solenoids)
02	
⋮	
24	24 stations

Note 1) Double wiring: 2-position single, double, 3-position and 4-position valves can be used on all manifold stations. Use of a 2-position single solenoid will result in an unused control signal. If this is not desired, order with a specified layout.  
Note 2) Specified layout: Indicate the wiring specifications on the manifold specification sheet. (Note that 2-position double, 3-position and 4-position valves cannot be used where single wiring has been specified.)  
Note 3) For the product without the SI Unit (S0), note the maximum number of solenoids of the SI Unit that will be mounted. If the layout is specified, indicate it on the manifold specification sheet.

\* This also includes the number of blanking plate assembly.

### How to Order Manifold Assembly

**Example**

SS5Y3-10SA3N-05D-C6...1 set (Manifold base part number)  
 \* SY3200-5U1 .....5 sets (2-position double part number)  
 ↳ The asterisk denotes the symbol for assembly.  
 Prefix it to the part numbers of the valve etc.

- The valve arrangement is numbered as the 1st station from the D side.
- Under the manifold base part number, state the valves to be mounted in order from the 1st station as shown in the figure above. If the arrangement becomes complicated, specify on the manifold specification sheet.

#### 5 P, E port entry

U	U side (2 to 10 stations)
D	D side (2 to 10 stations)
B	Both sides (2 to 24 stations)

#### 6 SUP/EXH block assembly

—	Internal pilot
S	Internal pilot, Built-in silencer <sup>Note 1) 2)</sup>
R	External pilot

Note 1) 3/5(E) port is plugged for the built-in silencer type.  
Note 2) When built-in silencer type is used, keep the exhaust port from coming in direct contact with water or other liquids.

## 7 A, B port size (Metric/One-touch fitting)

	A, B port	Type 10/Side Ported			Type 11/Bottom Ported	
		SY3000	SY5000	SY7000	SY5000	SY7000
<b>C2</b>	Ø 2	●	—	—	—	—
<b>C3</b>	Ø 3.2	●	—	—	—	—
<b>C4</b>	Ø 4	●	●	—	●	—
<b>C6</b>	Ø 6	●	●	●	●	●
<b>C8</b>	Ø 8	—	●	●	●	●
<b>C10</b>	Ø 10	—	—	●	—	●
<b>C12</b>	Ø 12	—	—	—	—	●
<b>CM (Note 1)</b>	Mixed sizes	●	●	●	●	●
<b>L4</b> <b>L6</b> <b>L8</b> <b>L10</b> <b>L12</b>	Upward	Ø 4	●	●	—	—
		Ø 6	●	●	●	—
		Ø 8	—	●	●	—
		Ø 10	—	—	●	—
		Ø 12	—	—	—	—
		Mixed sizes	●	●	●	—
<b>B4</b> <b>B6</b> <b>B8</b> <b>B10</b> <b>B12</b>	Downward	Ø 4	●	●	—	—
		Ø 6	●	●	●	—
		Ø 8	—	●	●	—
		Ø 10	—	—	●	—
		Ø 12	—	—	—	—
		Mixed sizes	●	●	●	—
<b>LM (Note 1)</b>	Mixed sizes	●	●	●	—	—
<b>P, E port (Note 3)</b>		Ø 8	Ø 10	Ø 12	Ø 10	Ø 12

## A, B port size (Inch/One-touch fitting)

	A, B port	Type 10/Side Ported			Type 11/Bottom Ported	
		SY3000	SY5000	SY7000	SY5000	SY7000
<b>N1</b>	Ø 1/8"	●	—	—	—	—
<b>N3</b>	Ø 5/32"	●	●	—	●	—
<b>N7</b>	Ø 1/4"	●	●	●	●	●
<b>N9</b>	Ø 5/16"	—	●	●	●	●
<b>N11</b>	Ø 3/8"	—	—	●	—	●
<b>CM (Note 1)</b>	Mixed sizes	●	●	●	●	●
<b>LN3</b> <b>LN7</b> <b>LN9</b>	Upward	Ø 5/32"	●	—	—	—
		Ø 1/4"	●	●	—	—
		Ø 5/16"	—	●	—	—
<b>LN11</b> <b>BN3</b> <b>BN7</b> <b>BN9</b> <b>BN11</b>	Downward	Ø 3/8"	—	—	●	—
		Ø 5/32"	●	—	—	—
		Ø 1/4"	●	●	—	—
		Ø 5/16"	—	●	—	—
<b>BN11</b>	Downward	Ø 3/8"	—	—	●	—
		Mixed sizes	●	●	●	—
<b>LM (Note 1)</b>	Mixed sizes	●	●	●	—	—
<b>P, E port (Note 3)</b>		Ø 5/16"	Ø 3/8"	Ø 1/2"	Ø 3/8"	Ø 1/2"

Note 1) Indicate the sizes on the manifold specification sheet.

Note 2) To avoid interference with the body or piping, select downward elbow port when mounting the optional spacer assembly. For details, refer to the **WEB catalogue** or the SY series catalogue (CAT. EUS11-103).

Note 3) The direction of P, E port fittings is the same as for A, B port. If selecting "LM", indicate it on the manifold specification sheet for the P, E port fitting direction.

## 8 Mounting and Option

	Mounting	Option	
		Name plate	Station number
—	Direct mounting	—	—
<b>AA</b>		●	●
<b>BA</b>		●	—
<b>D</b> (Note 1)	DIN rail mounting	—	—
<b>A</b> (Note 1)		●	●
<b>B</b> (Note 1)		●	—

Note 1) Refer to "DIN Rail Option" below.

\* Select the direct mounting type for Type 11 (Bottom ported).

### DIN Rail Option

—	With DIN bracket, DIN rail with standard length
<b>0</b>	With DIN bracket, without DIN rail
<b>3</b> (Note)	With DIN bracket, DIN rail for 3 stations
⋮	⋮
<b>24</b> (Note)	With DIN bracket, DIN rail for 24 stations

Note) Specify a longer rail than the length of valve stations.

\* If the DIN rail must be mounted without an SI Unit, select "D0" and order the DIN rail separately. Refer to L3 of the dimensions for the DIN rail length. For the DIN rail part number, refer to the **WEB catalogue** or the SY series catalogue (CAT. EUS11-103).

\* For the fixation of DIN rail mounting type manifold, refer to the **WEB catalogue** or the SY series catalogue (CAT. EUS11-103).



# Series SY3000/5000/7000

## How to Order Valves (With mounting screw)

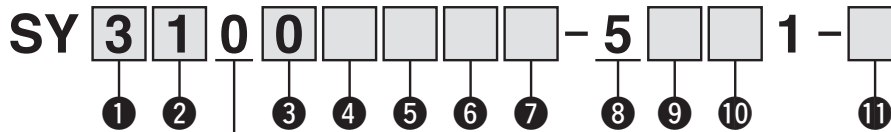

• Side/Bottom ported

### 1 Series

3	SY3000
5	SY5000
7	SY7000

### 2 Type of actuation

1	2-position	Single
2		Double
3	3-position	Closed centre
4		Exhaust centre
5		Pressure centre
A (Note)	4-position dual	N.C./N.C.
B (Note)		N.O./N.O.
C (Note)	3-port valve	N.C./N.O.

Note) Select the rubber seal type for the 4-position dual 3-port valve.

### 3 Seal type

0	Rubber seal
1	Metal seal

### 4 Pilot type

—	Internal pilot
R	External pilot

### 5 Back pressure check valve

—	None
H (Note)	Built-in

Note) Select the rubber seal type when the back pressure check valve is built-in. Manifold installed type is available if the back pressure check valve is required for a valve with metal seal. For ordering example, refer to the **WEB catalogue** or the SY series catalogue (CAT. EUS11-103). However, it is not recommended to use the built-in valve type and the manifold installed type at the same time because it will reduce the flow.

\* Select “—” for 3-position type and the SY7000.

### 6 Pilot valve option

—	Standard (0.7 MPa)
B	Quick response type (0.7 MPa)
K (Note)	High pressure type (1.0 MPa)

Note) Select the metal seal type for high pressure type.

### 7 Coil type

—	Standard
T	With power saving circuit (Continuous duty type) (Note 1) 2)

Note 1) Be sure to select the power saving circuit type when the valve is continuously energised for long periods of time.

Note 2) Be careful of the energising time when the power saving circuit is selected. For details, refer to the **WEB catalogue** or the SY series catalogue (CAT. EUS11-103).

### 8 Rated voltage

5	24 V DC
---	---------

### 9 Light/surge voltage suppressor and common specification

	With light	Surge voltage suppressor	Common specification
R	—	●	Non-polar
U	●		Negative common
NS	—		
NZ	●		

\* Select “NZ” type for with the power saving circuit.

### 10 Manual override

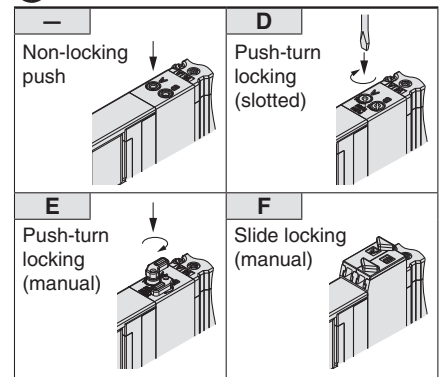

### 11 Type of mounting screw

—	Round head combination screw
B	Hexagon socket head cap screw
K	Round head combination screw (Falling-out-prevention type) (Note)
H	Hexagon socket head cap screw (Falling-out-prevention type) (Note)

Note) For “K” and “H”, the valve body cover has a drop prevention construction to stop the mounting screws from falling out when the valve is removed for maintenance etc.

\* **When ordering a valve individually, the base gasket is not included.** Since the base gasket is attached to the manifold, please order the base gasket separately if it is needed for maintenance service. For details, refer to the **WEB catalogue** or the SY series catalogue (CAT. EUS11-103).  
\* Select “—” or “K” for the optional individual SUP/EXH spacer assembly, interface regulator or double check spacer assembly with residual pressure release valve.

# Gateway Decentralised System 2

## 5 Port Solenoid Valve

### Series SY3000/5000/7000



RoHS

Type 12  
Top Ported

Gateway Decentralised System 2

SY

VQC

S0700

SV

For detailed specifications, Common Precautions and Specific Product Precautions, refer to the **WEB catalogue** or the SY series catalogue (CAT. EUS11-103).

### How to Order Manifold

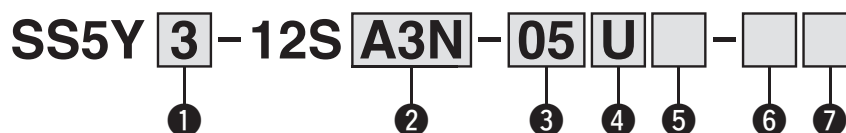

#### ① Series

3	SY3000
5	SY5000
7	SY7000

\* For mixed mounting, refer to the **WEB catalogue** or the SY series catalogue (CAT. EUS11-103).

#### ② SI Unit (Number of outputs, Output polarity, Max. number of valve stations)

0	Without SI Unit
A3N	32 outputs <sup>Note 1, 4</sup> , 1 to 16 stations (24 stations <sup>Note 3</sup> ), Negative common <sup>Note 2</sup>

Note 1) 16 outputs can be set by switching the built-in setting switch.

Note 2) Ensure a match with the common specification of the valve.

Note 3) ( ): Maximum number of stations for mixed single and double wiring.

Note 4) When using the SI Unit with 32 outputs, use the GW Unit compatible with the EX500 Gateway Decentralised System 2 (128 points).

#### ③ Valve stations

Stations	Note
02	2 stations Double wiring <sup>Note 1</sup>
⋮	
16	
02	2 stations Specified layout <sup>Note 2</sup> (Available up to 32 solenoids)
⋮	
24	

Note 1) Double wiring: 2-position single, double, 3-position and 4-position valves can be used on all manifold stations. Use of a 2-position single solenoid will result in an unused control signal. If this is not desired, order with a specified layout.

Note 2) Specified layout: Indicate the wiring specifications on the manifold specification sheet. (Note that 2-position double, 3-position and 4-position valves cannot be used where single wiring has been specified.)

Note 3) For the product without the SI Unit (S0), note the maximum number of solenoids of the SI Unit that will be mounted. If the layout is specified, indicate it on the manifold specification sheet.

\* This also includes the number of blanking plate assembly.

#### ④ P, E port entry

U <sup>Note</sup>	U side (2 to 10 stations)
D <sup>Note</sup>	D side (2 to 10 stations)
B	Both sides (2 to 24 stations)

Note) For type "S", supply/exhaust block assembly with built-in silencer, choose "U" or "D" for P, E port entry.

#### ⑤ SUP/EXH block assembly

—	Internal pilot
S <sup>Note 1</sup>	Internal pilot, Built-in silencer <sup>Note 2</sup>
R	External pilot

Note 1) For type "S", supply/exhaust block assembly with built-in silencer, choose "U" or "D" for P, E port entry. 3/5(E) port is plugged. The silencer exhaust port is located on the opposite side of P, E port entry. (Example: When the P, E port entry is D side, the silencer exhaust port is U side.)

Note 2) When the built-in silencer type is used, keep the exhaust port from coming in direct contact with water or other liquids.

### How to Order Manifold Assembly

#### Example

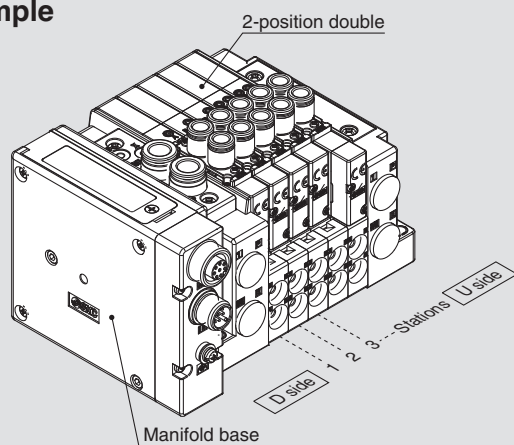

SS5Y3-12SA3N-05D ..... 1 set (Manifold base part number)  
 \* SY3230-5U1-C6 ..... 5 sets (2-position double part number)  
 ↳ The asterisk denotes the symbol for assembly.  
 Prefix it to the part numbers of the valve etc.

- The valve arrangement is numbered as the 1st station from the D side.
- Under the manifold base part number, state the valves to be mounted in order from the 1st station as shown in the figure above. If the arrangement becomes complicated, specify on the manifold specification sheet.

#### ⑥ P, E port size (One-touch fittings)

	SY3000	SY5000	SY7000
—	Ø 8	Ø 10	Ø 12
N <sup>Note</sup>	Ø 5/16"	Ø 3/8"	Ø 1/2"

Note) For "N", sizes are in inches.

#### ⑦ Mounting

—	Direct mounting
D	With DIN bracket, DIN rail with standard length
D0	With DIN bracket, without DIN rail
D3 <sup>Note</sup>	With DIN bracket, DIN rail for 3 stations
⋮	⋮
D24 <sup>Note</sup>	With DIN bracket, DIN rail for 24 stations

Note) Specify a longer rail than the length of valve stations.

\* If the DIN rail must be mounted without an SI Unit, select "D0". Then, refer to L3 of the dimensions for the DIN rail length and order separately. For the DIN rail part number, refer to the **WEB catalogue** or the SY series catalogue (CAT. EUS11-103).

\* For the fixation of DIN rail mounting type manifold, refer to the **WEB catalogue** or the SY series catalogue (CAT. EUS11-103).

# Series SY3000/5000/7000

## How to Order Valves (With mounting screw)

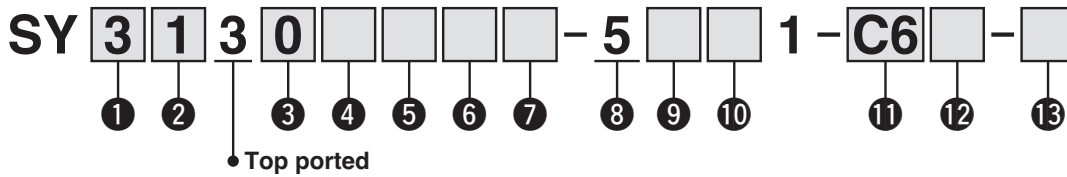

### 1 Series

3	SY3000
5	SY5000
7	SY7000

### 2 Type of actuation

1	2-position	Single
2		Double
3	3-position	Closed centre
4		Exhaust centre
5		Pressure centre
A (Note)	4-position dual	N.C./N.C.
B (Note)		N.O./N.O.
C (Note)	3-port valve	N.C./N.O.

Note) Select the rubber seal type for the 4-position dual 3-port valve.

### 3 Seal type

0	Rubber seal
1	Metal seal

### 4 Pilot type

—	Internal pilot
R	External pilot

### 5 Back pressure check valve (Built-in valve type)

—	None
H (Note)	Built-in

Note) Select the rubber seal type when the back pressure check valve is built-in. Manifold installed type is available if the back pressure check valve is required for a valve with metal seal. For ordering example, refer to the SY series catalogue (CAT. EUS11-103). However, it is not recommended to use the built-in valve type and the manifold installed type at the same time because it will reduce the flow.

\* Select "—" for 3-position type and the SY7000.

### 6 Pilot valve option

—	Standard (0.7 MPa)
B	Quick response type (0.7 MPa)
K (Note)	High pressure type (1.0 MPa)

Note) Select the metal seal type for high pressure type.

### 7 Coil type

—	Standard
T	With power saving circuit (Continuous duty type) (Note 1) 2)

Note 1) Be sure to select the power saving circuit type when the valve is continuously energised for long periods of time.

Note 2) Be careful of the energising time when the power saving circuit is selected. For details, refer to the SY series catalogue (CAT. EUS11-103).

### 8 Rated voltage

5	24 V DC
---	---------

### 9 Light/surge voltage suppressor and common specification

	With light	Surge voltage suppressor	Common specification
R	—	●	Non-polar
U	●		
NS	—		
NZ	●		Negative common

\* Select "NZ" type for with the power saving circuit.

### 10 Manual override

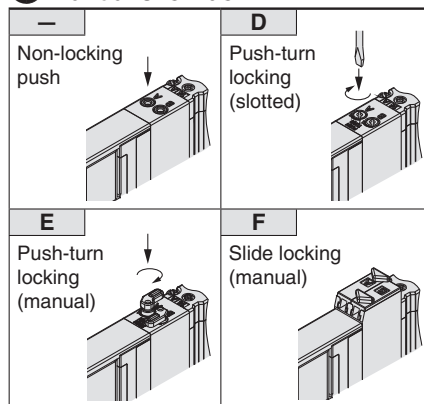

### 11 A, B port size

#### Thread piping

	Port size	SY3000	SY5000	SY7000
M5	M5 x 0.8	●	—	—
O1	1/8	—	●	—
O2	1/4	—	—	●

#### One-touch fitting (Metric)

	A, B port	SY3000	SY5000	SY7000
C2	Ø 2	●	—	—
C3	Ø 3.2	●	—	—
C4	Ø 4	●	●	—
C6	Ø 6	●	●	●
C8	Ø 8	—	●	●
C10	Ø 10	—	—	●
C12	Ø 12	—	—	●

#### One-touch fitting (Inch)

	A, B port	SY3000	SY5000	SY7000
N1	Ø 1/8"	●	—	—
N3	Ø 5/32"	●	●	—
N7	Ø 1/4"	●	●	●
N9	Ø 5/16"	—	●	●
N11	Ø 3/8"	—	—	●

### 12 A, B port thread type

—	Rc
F	G
N	NPT
T	NPTF

\* Select "—" for M5.

### 13 Type of mounting screw

—	Round head combination screw
B	Hexagon socket head cap screw
K	Round head combination screw (Falling-out-prevention type (Note))
H	Hexagon socket head cap screw (Falling-out-prevention type (Note))

Note) For "K" and "H", the valve body cover has a drop prevention construction to stop the mounting screws from falling out when the valve is removed for maintenance etc.

\* **When ordering a valve individually, the base gasket is not included.**

Since the base gasket is attached to the manifold, please order the base gasket separately if it is needed for maintenance service. For details, refer to the SY series catalogue (CAT. EUS11-103).

\* Select "—" or "K" for the optional individual SUP/EXH spacer assembly or interface regulator.

For dimensions of Type 1 1 /Bottom ported type and Type 12/Top ported type, refer to the **WEB catalogue** or the SY series catalogue (CAT. EUS11-103).



## Dimensions

Type 10/Side Ported

Series SY3000

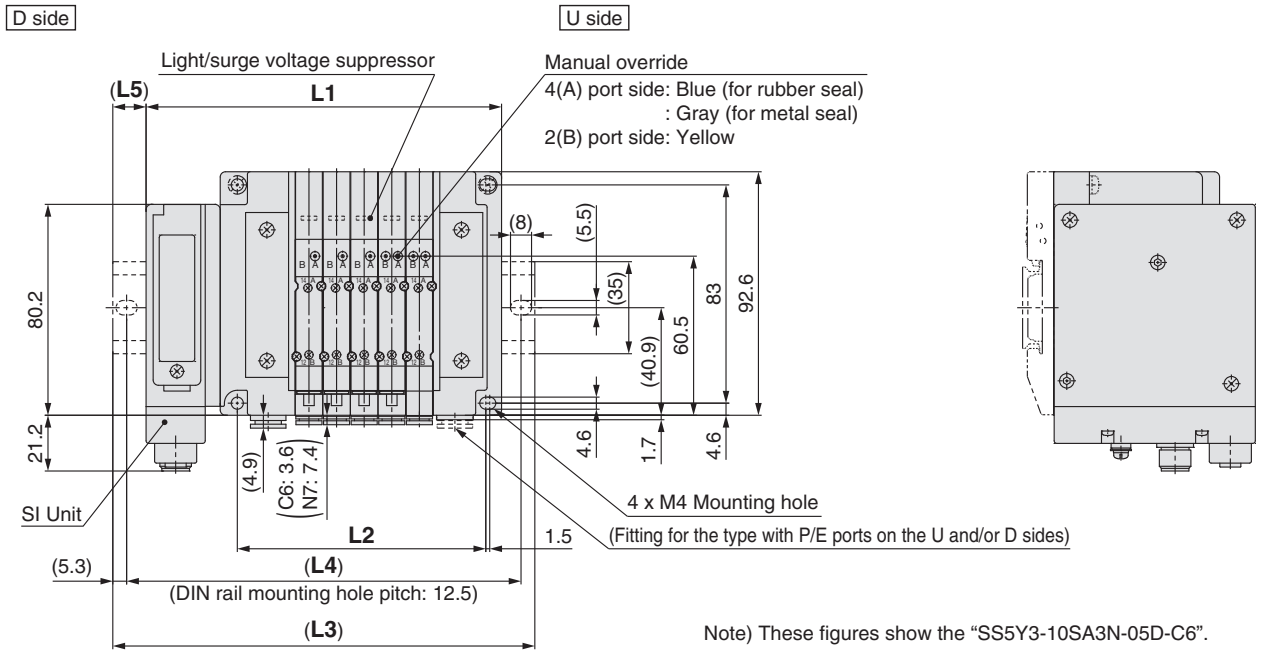
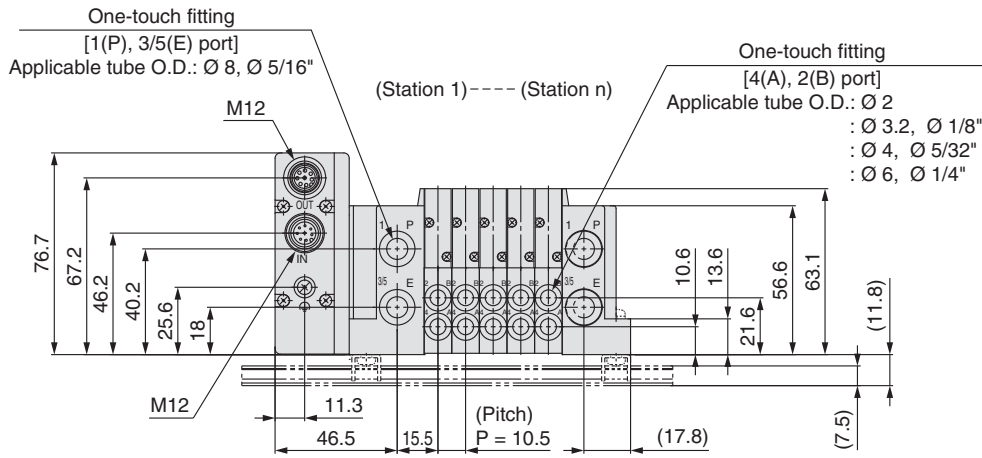

### L: Dimensions

n: Stations

L \ n	2	3	4	5	6	7	8	9	10	11	12	13	14	15	16
L1	103.7	114.2	124.7	135.2	145.7	156.2	166.7	177.2	187.7	198.2	208.7	219.2	229.7	240.2	250.7
L2	63	73.5	84	94.5	105	115.5	126	136.5	147	157.5	168	178.5	189	199.5	210
L3	135.5	148	148	160.5	173	185.5	198	210.5	223	223	235.5	248	260.5	273	285.5
L4	125	137.5	137.5	150	162.5	175	187.5	200	212.5	212.5	225	237.5	250	262.5	275
L5	16	17	11.5	12.5	13.5	14.5	15.5	16.5	17.5	12.5	13.5	14.5	15.5	16.5	17.5

L \ n	17	18	19	20	21	22	23	24
L1	261.2	271.7	282.2	292.7	303.2	313.7	324.2	334.7
L2	220.5	231	241.5	252	262.5	273	283.5	294
L3	285.5	298	310.5	323	335.5	348	348	360.5
L4	275	287.5	300	312.5	325	337.5	337.5	350
L5	12	13	14	15	16	17	12	13

For dimensions of Type 11/Bottom ported type and Type 12/Top ported type, refer to the **WEB catalogue** or the SY series catalogue (CAT. EUS11-103).

# Series SY5000

## Dimensions

Type 10/Side Ported Series SY5000

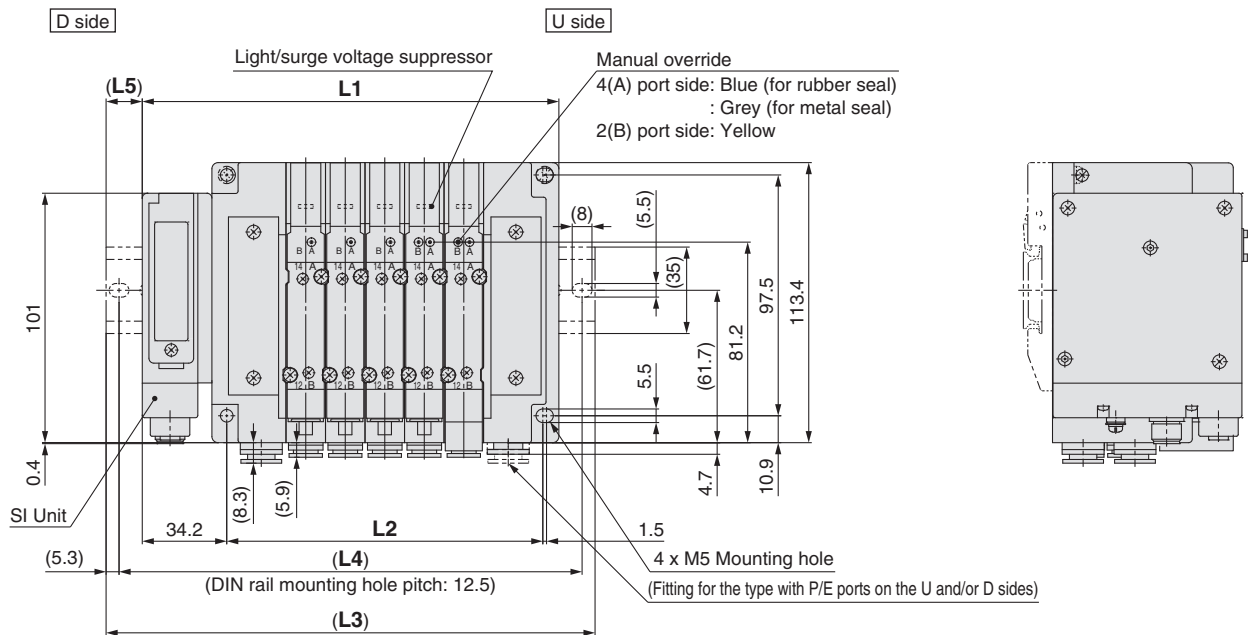
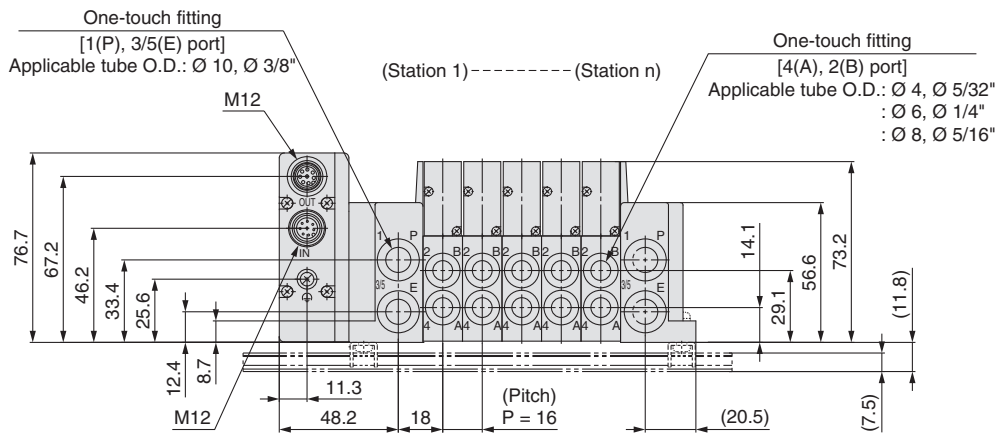

Note) These figures show the "SS5Y5-10SA3N-05D-C8".

### L: Dimensions

n: Stations

L \ n	2	3	4	5	6	7	8	9	10	11	12	13	14	15	16
L1	120.7	136.7	152.7	168.7	184.7	200.7	216.7	232.7	248.7	264.7	280.7	296.7	312.7	328.7	344.7
L2	80	96	112	128	144	160	176	192	208	224	240	256	272	288	304
L3	148	160.5	185.5	198	210.5	235.5	248	260.5	273	298	310.5	323	348	360.5	373
L4	137.5	150	175	187.5	200	225	237.5	250	262.5	287.5	300	312.5	337.5	350	362.5
L5	13.5	12	16.5	14.5	13	17.5	15.5	14	12	16.5	15	13	17.5	16	14

L \ n	17	18	19	20	21	22	23	24
L1	360.7	376.7	392.7	408.7	424.7	440.7	456.7	472.7
L2	320	336	352	368	384	400	416	432
L3	385.5	410.5	423	435.5	448	473	485.5	498
L4	375	400	412.5	425	437.5	462.5	475	487.5
L5	12.5	17	15	13.5	11.5	16	14.5	12.5

For dimensions of Type 11/Bottom ported type and Type 12/Top ported type, refer to the **WEB catalogue** or the SY series catalogue (CAT. EUS11-103).

## Dimensions

Type 10/Side Ported

Series SY7000

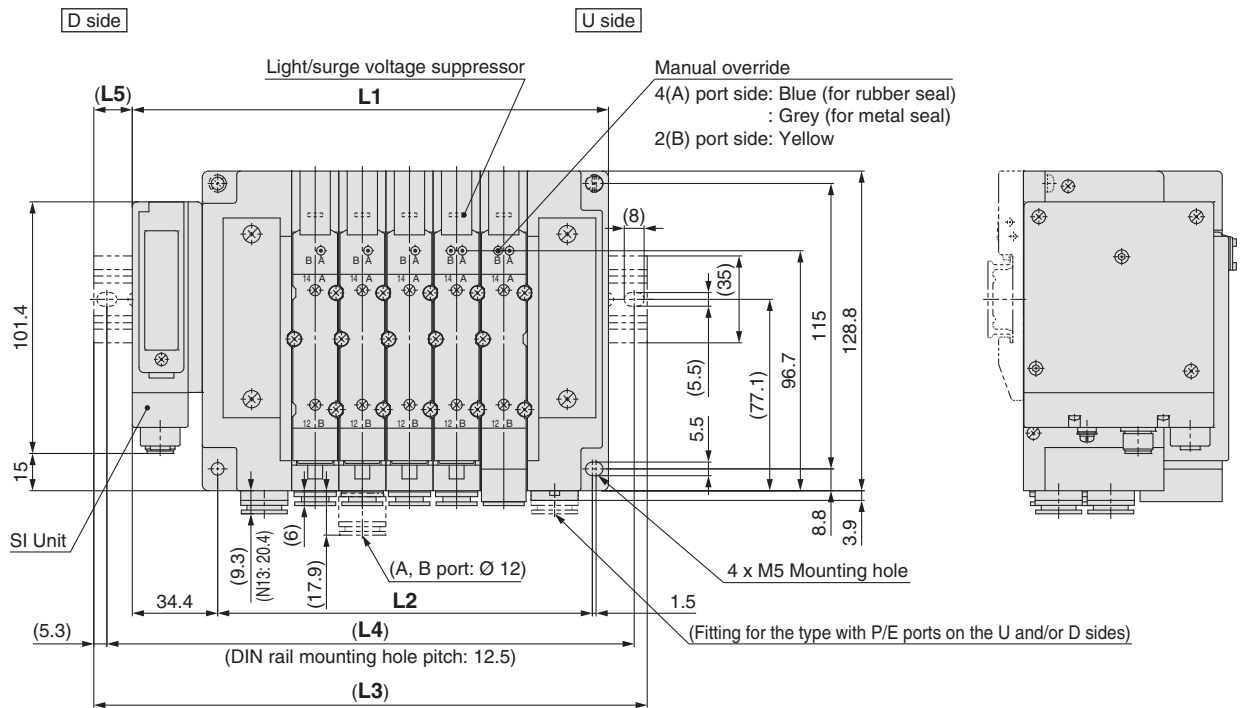
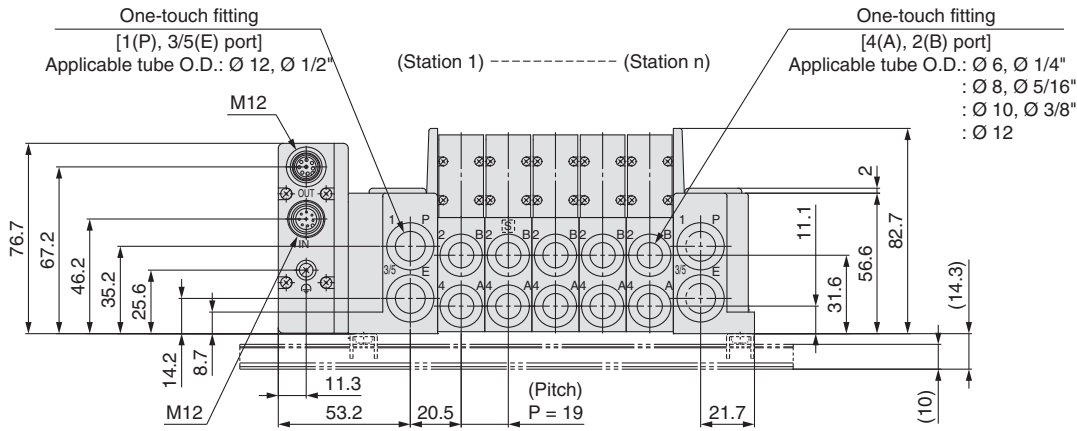

Note) These figures show the "SS5Y7-10SA3N-05D-C10".

### L: Dimensions

n: Stations

L \ n	2	3	4	5	6	7	8	9	10	11	12	13	14	15	16
L1	134.9	153.9	172.9	191.9	210.9	229.9	248.9	267.9	286.9	305.9	324.9	343.9	362.9	381.9	400.9
L2	94	113	132	151	170	189	208	227	246	265	284	303	322	341	360
L3	160.5	185.5	198	223	235.5	260.5	273	298	310.5	335.5	348	373	398	410.5	435.5
L4	150	175	187.5	212.5	225	250	262.5	287.5	300	325	337.5	362.5	387.5	400	425
L5	13	16	12.5	15.5	12.5	15.5	12	15	12	15	11.5	14.5	17.5	14.5	17.5

L \ n	17	18	19	20	21	22	23	24
L1	419.9	438.9	457.9	476.9	495.9	514.9	533.9	552.9
L2	379	398	417	436	455	474	493	512
L3	448	473	485.5	510.5	523	548	560.5	585.5
L4	437.5	462.5	475	500	512.5	537.5	550	575
L5	14	17	14	17	13.5	16.5	13.5	16.5

For dimensions of Type 11/Bottom ported type and Type 12/Top ported type, refer to the **WEB catalogue** or the SY series catalogue (CAT. EUS11-103).

# Gateway Decentralised System 2

## 5 Port Solenoid Valve



### Series VQC1000

For detailed specifications, Common Precautions and Specific Product Precautions, refer to the **WEB catalogue** or the VQC1000/2000 series catalogue (CAT. EUS11-101).

#### How to Order Manifold

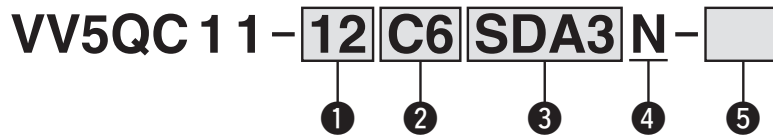

#### 1 Valve stations

	Stations	Note
01	1 station	Double wiring
⋮	⋮	
12	12 stations	Mixed wiring, Specified layout <sup>Note</sup> (Available up to 24 solenoids)
01	1 station	
⋮	⋮	
24	24 stations	

Note) Specified layout: Indicate the wiring specifications on the manifold specification sheet. (Note that 2-position double, 3-position and 4-position valves cannot be used where single wiring has been specified.) In addition, select the option "K".

#### 2 A, B port size

##### Metric size

C3	Straight piping: Ø 3.2 One-touch fitting
C4	Straight piping: Ø 4 One-touch fitting
C6	Straight piping: Ø 6 One-touch fitting
M5	Straight piping: M5 thread
CM <sup>Note 1)</sup>	Straight piping: Mixed sizes and with port plug
L3	Top ported elbow: Ø 3.2 One-touch fitting
L4	Top ported elbow: Ø 4 One-touch fitting
L6	Top ported elbow: Ø 6 One-touch fitting
L5	Top ported elbow: M5 thread
B3	Bottom ported elbow: Ø 3.2 One-touch fitting
B4	Bottom ported elbow: Ø 4 One-touch fitting
B6	Bottom ported elbow: Ø 6 One-touch fitting
B5	Bottom ported elbow: M5 thread
LM <sup>Note 1)</sup>	Elbow piping: Mixed sizes and with port plug
MM <sup>Note 2)</sup>	Mixed size for different types of piping, option installed

##### Inch size

N1	Straight piping: Ø 1/8" One-touch fitting
N3	Straight piping: Ø 5/32" One-touch fitting
N7	Straight piping: Ø 1/4" One-touch fitting
NM <sup>Note 1)</sup>	Straight piping: Mixed sizes and with port plug
LN1	Top ported elbow: Ø 1/8" One-touch fitting
LN3	Top ported elbow: Ø 5/32" One-touch fitting
LN7	Top ported elbow: Ø 1/4" One-touch fitting
BN1	Bottom ported elbow: Ø 1/8" One-touch fitting
BN3	Bottom ported elbow: Ø 5/32" One-touch fitting
BN7	Bottom ported elbow: Ø 1/4" One-touch fitting
LNM <sup>Note 1)</sup>	Elbow piping: Mixed sizes and with port plug
BNM <sup>Note 2)</sup>	Mixed size for different types of piping, option installed

Note 1) Indicate the sizes on the manifold specification sheet.

Note 2) When a combination of straight and elbow piping is or when option such as dual flow fitting assembly is mounted, please mention the mounting conditions in the Manifold Specification.

#### 3 SI Unit (Number of outputs, Max. number of valve stations)

SD0	Without SI Unit
SDA3	32 outputs <sup>Note 1, 3)</sup> , 1 to 12 stations (24 stations <sup>Note 2)</sup> )

Note 1) Due to the internal wiring of the valve, the maximum number of outputs is 24 points. 16 outputs can be set by switching the built-in setting switch.

Note 2) ( ): Maximum number of stations for mixed single and double wiring.

Note 3) When using the SI Unit with 32 outputs, use the GW Unit compatible with the EX500 Gateway Decentralised System 2 (128 points).

#### 4 SI Unit (Output polarity)

-	(Without SI Unit)
N	Negative common

\* Ensure a match with the common specification of the valve to be used.

#### 5 Option

-	None
B <sup>Note 1)</sup>	With back pressure check valve (All stations)
D	With DIN bracket, DIN rail with standard length
D0	With DIN bracket, without DIN rail
D□ <sup>Note 2)</sup>	With DIN bracket, DIN rail for □ stations
K <sup>Note 3)</sup>	Special wiring specification (Except double wiring)
N	With name plate
R <sup>Note 4)</sup>	External pilot
S <sup>Note 5)</sup>	Built-in silencer, Direct exhaust

\* When multiple symbols are specified, indicate them alphabetically. Example) -BRS

Note 1) When a back pressure check valve is used only for specified station, specify the back pressure check valve part number, and specify the station number to which the valve is mounted, on the manifold specification sheet.

Note 2) □: Specify a longer rail than the length of valve stations.  
Example) "-D08"  
In this case, the valves will be mounted on the DIN rail for 8 stations, regardless of the number of manifold stations.

Note 3) When single wiring and double wiring are mixed, specify wiring type of each station on the manifold specification sheet.

Note 4) For external pilot option "-R", indicate the external pilot specification "R" for the applicable valves as well.

Note 5) Built-in silencer type does not satisfy IP67.

**How to Order Valves**

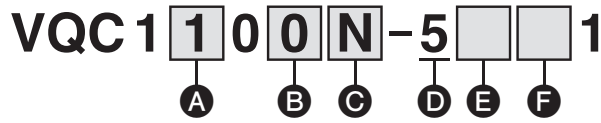

**A Type of actuation**

<b>1</b>	2-position single	<b>A</b> Note)	4-position dual 3-port valve (N.C./N.C.)
<b>2</b>	2-position double	<b>B</b> Note)	4-position dual 3-port valve (N.O./N.O.)
<b>3</b>	3-position closed centre	<b>C</b> Note)	4-position dual 3-port valve (N.C./N.O.)
<b>4</b>	3-position exhaust centre		
<b>5</b>	3-position pressure centre		

Note) Only rubber seal type

**B Seal type**

<b>0</b>	Metal seal
<b>1</b>	Rubber seal

**C Function**

<b>N</b>	Negative common, Standard (0.4 W)
<b>BN</b>	Negative common, Quick response type (0.95 W)
<b>KN</b> Note 1)	Negative common, High pressure type (1.0 MPa, 0.95 W)
<b>NR</b> Note 2)	Negative common, External pilot
Note 1) 2) <b>KNR</b>	Negative common, High pressure type (1.0 MPa, 0.95 W), External pilot

Note 1) For "KN" or "KNR" high pressure type, select "0" metal seal.

Note 2) For "NR" or "KNR" external pilot, select "1" to "5". 4-position dual 3-port valve is unavailable.

**D Coil voltage**

<b>5</b>	24 V DC
----------	---------

**E Light/surge voltage suppressor**

<b>—</b>	With light/surge voltage suppressor
----------	-------------------------------------

**F Manual override**

<b>—</b>	Non-locking push (tool required)	
<b>B</b>	Locking push (tool required)	
<b>C</b>	Turn locking (manual)	
<b>D</b>	Slide locking (manual)	

**How to Order Manifold Assembly**

**Example**

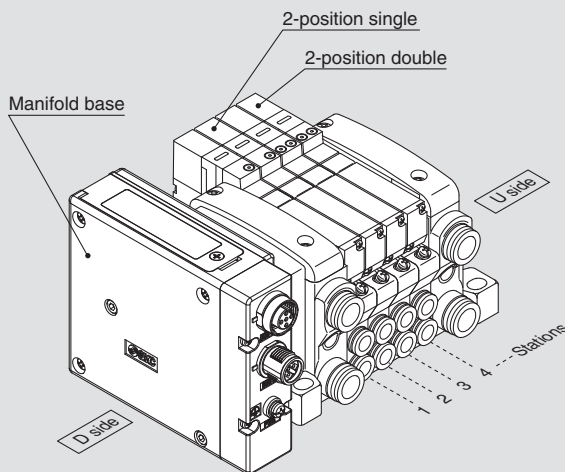

VV5QC11-04C6SDA3N.....1 set (Manifold base part number)  
 \* VQC1100N-51.....2 sets (2-position single part number)  
 \* VQC1200N-51.....2 sets (2-position double part number)

↳ The asterisk denotes the symbol for assembly. Prefix it to the part numbers of the valve etc.

- The valve arrangement is numbered as the 1st station from the D side.
- Under the manifold base part number, state the valves to be mounted in order from the 1st station as shown in the figure above. If the arrangement becomes complicated, specify on the manifold specification sheet.

# Series VQC1000

## Dimensions

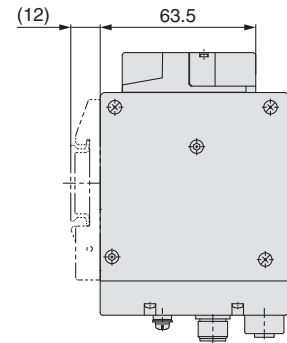
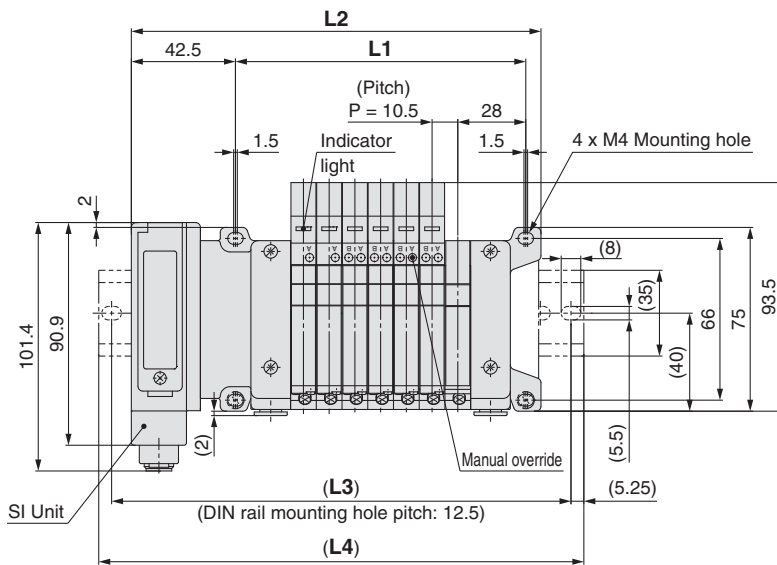
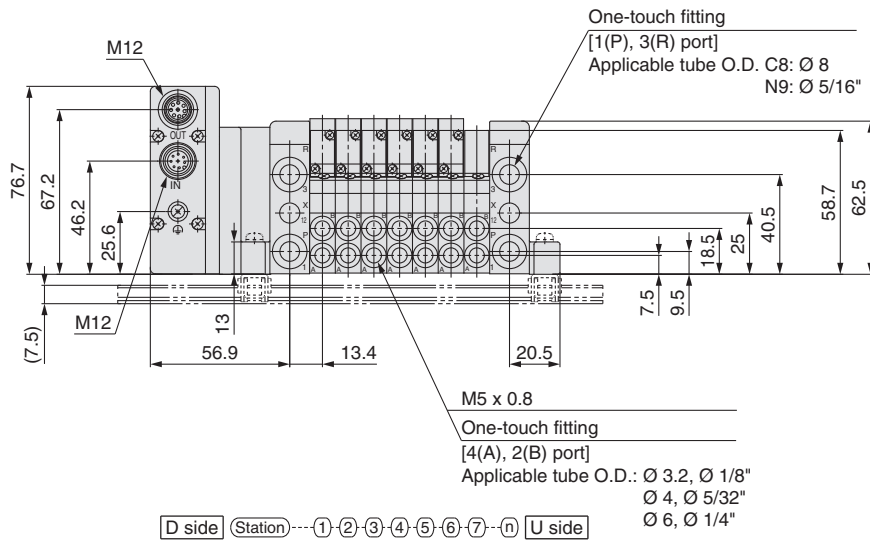

### L: Dimensions

n: Stations

L \ n	1	2	3	4	5	6	7	8	9	10	11	12	13	14	15
L1	55.5	66	76.5	87	97.5	108	118.5	129	139.5	150	160.5	171	181.5	192	202.5
L2	104.2	114.7	125.2	135.7	146.2	156.7	167.2	177.7	188.2	198.7	209.2	219.7	230.2	240.7	251.2
L3	125	137.5	150	162.5	175	187.5	187.5	200	212.5	225	237.5	250	250	262.5	275
L4	135.5	148	160.5	173	185.5	198	198	210.5	223	235.5	248	260.5	260.5	273	285.5

L \ n	16	17	18	19	20	21	22	23	24
L1	213	223.5	234	244.5	255	265.5	276	286.5	297
L2	261.7	272.2	282.7	293.2	303.7	314.2	324.7	335.2	345.7
L3	287.5	300	312.5	325	325	337.5	350	362.5	375
L4	298	310.5	323	335.5	335.5	348	360.5	373	385.5

# Gateway Decentralised System 2

## 5 Port Solenoid Valve



### Series VQC2000

For detailed specifications, Common Precautions and Specific Product Precautions, refer to the **WEB catalogue** or the VQC1000/2000 series catalogue (CAT. EUS11-101).

### How to Order Manifold

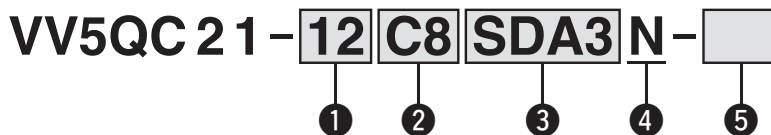

#### ① Valve stations

	Stations	Note
01	1 station	Double wiring
⋮	⋮	
12	12 stations	Mixed wiring, Specified layout <sup>Note)</sup> (Available up to 24 solenoids)
01	1 station	
⋮	⋮	
24	24 stations	

Note) Specified layout: Indicate the wiring specifications on the manifold specification sheet. (Note that 2-position double, 3-position and 4-position valves cannot be used where single wiring has been specified.) In addition, select the option "K".

#### ③ SI Unit (Number of outputs, Max. number of valve stations)

SD0	Without SI Unit
SDA3	32 outputs <sup>Note 1, 3)</sup> , 1 to 12 stations (24 stations <sup>Note 2)</sup> )

Note 1) Due to the internal wiring of the valve, the maximum number of outputs is 24 points. 16 outputs can be set by switching the built-in setting switch.

Note 2) ( ): Maximum number of stations for mixed single and double wiring.

Note 3) When using the SI Unit with 32 outputs, use the GW Unit compatible with the EX500 Gateway Decentralised System 2 (128 points).

#### ② A, B port size

##### Metric size

C4	Straight piping: Ø 4 One-touch fitting
C6	Straight piping: Ø 6 One-touch fitting
C8	Straight piping: Ø 8 One-touch fitting
CM <sup>Note 1)</sup>	Straight piping: Mixed sizes and with port plug
L4	Top ported elbow: Ø 4 One-touch fitting
L6	Top ported elbow: Ø 6 One-touch fitting
L8	Top ported elbow: Ø 8 One-touch fitting
B4	Bottom ported elbow: Ø 4 One-touch fitting
B6	Bottom ported elbow: Ø 6 One-touch fitting
B8	Bottom ported elbow: Ø 8 One-touch fitting
LM <sup>Note 1)</sup>	Elbow piping: Mixed sizes and with port plug
MM <sup>Note 2)</sup>	Mixed size for different types of piping, option installed

##### Inch size

N1	Straight piping: Ø 1/8" One-touch fitting
N3	Straight piping: Ø 5/32" One-touch fitting
N7	Straight piping: Ø 1/4" One-touch fitting
NM <sup>Note 1)</sup>	Straight piping: Mixed sizes and with port plug
LN1	Top ported elbow: Ø 1/8" One-touch fitting
LN3	Top ported elbow: Ø 5/32" One-touch fitting
LN7	Top ported elbow: Ø 1/4" One-touch fitting
BN1	Bottom ported elbow: Ø 1/8" One-touch fitting
BN3	Bottom ported elbow: Ø 5/32" One-touch fitting
BN7	Bottom ported elbow: Ø 1/4" One-touch fitting
LNM <sup>Note 1)</sup>	Elbow piping: Mixed sizes and with port plug
BNM <sup>Note 2)</sup>	Mixed size for different types of piping, option installed

Note 1) Indicate the sizes on the manifold specification sheet.

Note 2) When a combination of straight and elbow piping is or when option such as dual flow fitting assembly is mounted, please mention the mounting conditions in the Manifold Specification.

#### ④ SI Unit (Output polarity)

—	(Without SI Unit)
N	Negative common

\* Ensure a match with the common specification of the valve to be used.

#### ⑤ Option

—	None
B <sup>Note 1)</sup>	With back pressure check valve (All stations)
D	With DIN bracket, DIN rail with standard length
D0	With DIN bracket, without DIN rail
D□ <sup>Note 2)</sup>	With DIN bracket, DIN rail for □ stations
K <sup>Note 3)</sup>	Special wiring specification (Except double wiring)
N	With name plate
R <sup>Note 4)</sup>	External pilot
S <sup>Note 5)</sup>	Built-in silencer, Direct exhaust
T <sup>Note 6)</sup>	P and R ports included on both sides of the U side

\* When multiple symbols are specified, indicate them alphabetically. Example) -BRS

Note 1) When a back pressure check valve is used only for specified station, specify the back pressure check valve part number, and specify the station number to which the valve is mounted, on the manifold specification sheet.

Note 2) □: Specify a longer rail than the length of valve stations.  
Example) "-D08"

In this case, the valves will be mounted on the DIN rail for 8 stations, regardless of the number of manifold stations.

Note 3) When single wiring and double wiring are mixed, specify wiring type of each station on the manifold specification sheet.

Note 4) For external pilot option "-R", indicate the external pilot specification "R" for the applicable valves as well.

Note 5) Built-in silencer type does not satisfy IP67.

Note 6) P and R ports are included on both sides of U side (cylinder port and coil side) with Ø 12 One-touch fittings.

## How to Order Valves

VQC 2 **1** **0** **0** **N** - **5** **□** **□** **1**

A
B
C
D
E
F

### A Type of actuation

1	2-position single	<b>A</b> Note)	4-position dual 3-port valve (N.C./N.C.)
2	2-position double	<b>B</b> Note)	4-position dual 3-port valve (N.O./N.O.)
3	3-position closed centre	<b>C</b> Note)	4-position dual 3-port valve (N.C./N.O.)
4	3-position exhaust centre		
5	3-position pressure centre		

Note) Only rubber seal type

### B Seal type

0	Metal seal
1	Rubber seal

### C Function

<b>N</b>	Negative common, Standard (0.4 W)
<b>BN</b>	Negative common, Quick response type (0.95 W)
<b>KN</b> Note 1)	Negative common, High pressure type (1.0 MPa, 0.95 W)
<b>NR</b> Note 2)	Negative common, External pilot
Note 1) 2) <b>KNR</b>	Negative common, High pressure type (1.0 MPa, 0.95 W), External pilot

Note 1) For "KN" or "KNR" high pressure type, select "0" metal seal.

Note 2) For "NR" or "KNR" external pilot, select "1" to "5". 4-position dual 3-port valve is unavailable.

### D Coil voltage

5	24 V DC
---	---------

### E Light/surge voltage suppressor

—	With light/surge voltage suppressor
---	-------------------------------------

### F Manual override

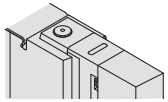
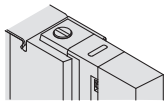
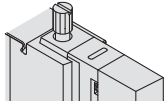
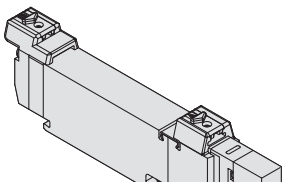
—	Non-locking push (tool required)	
<b>B</b>	Locking push (tool required)	
<b>C</b>	Turn locking (manual)	
<b>D</b>	Slide locking (manual)	

## How to Order Manifold Assembly

### Example

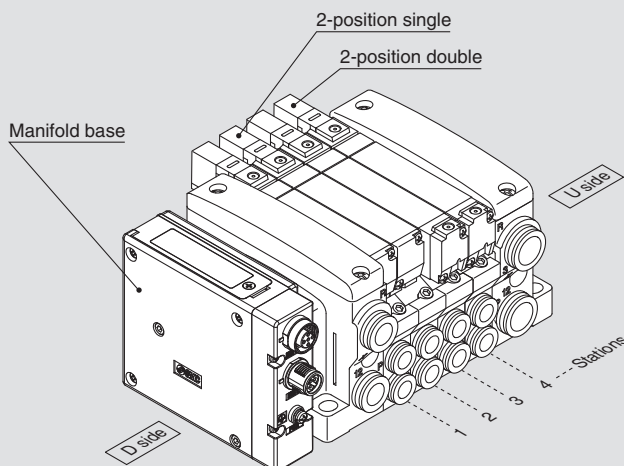

VV5QC21-04C6SDA3N.....1 set (Manifold base part number)  
 \* VQC2100N-51.....2 sets (2-position single part number)  
 \* VQC2200N-51.....2 sets (2-position double part number)

↳ The asterisk denotes the symbol for assembly. Prefix it to the part numbers of the valve etc.

- The valve arrangement is numbered as the 1st station from the D side.
- Under the manifold base part number, state the valves to be mounted in order from the 1st station as shown in the figure above. If the arrangement becomes complicated, specify on the manifold specification sheet.



Dimensions

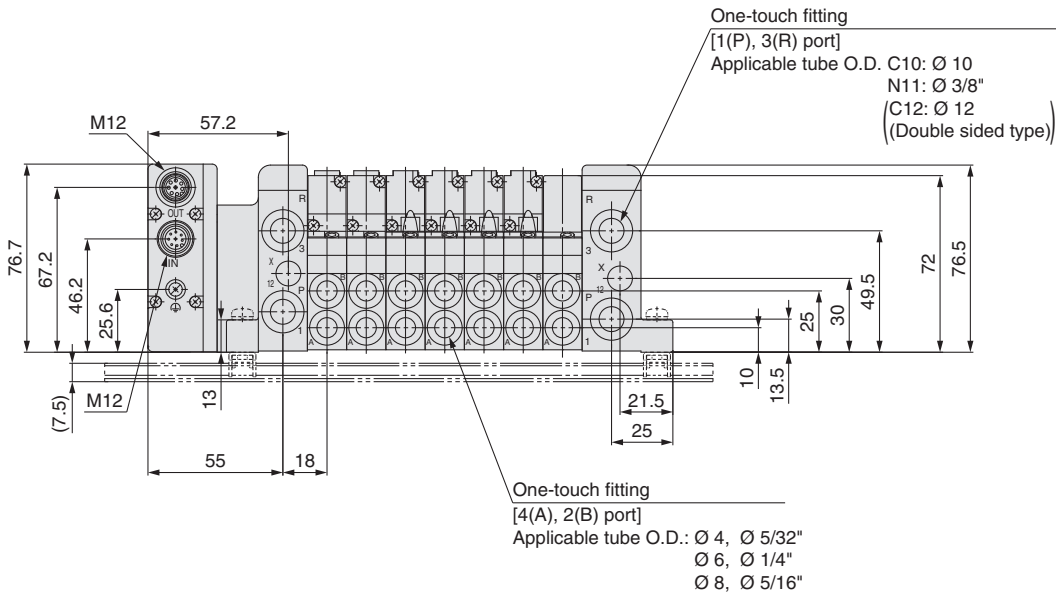

D side Station ① ② ③ ④ ⑤ ⑥ ⑦ n U side

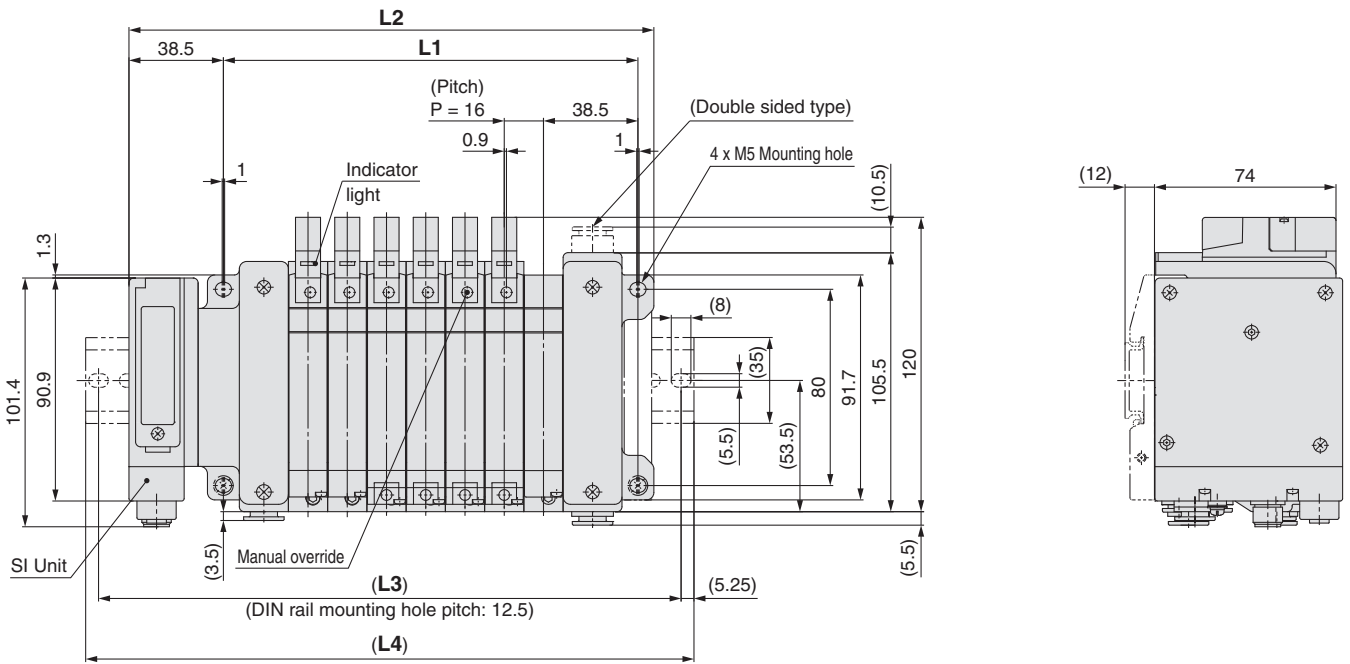

L: Dimensions

n: Stations

L \ n	1	2	3	4	5	6	7	8	9	10	11	12	13	14	15
L1	73	89	105	121	137	153	169	185	201	217	233	249	265	281	297
L2	118	134	150	166	182	198	214	230	246	262	278	294	310	326	342
L3	137.5	162.5	175	187.5	212.5	225	237.5	250	275	287.5	300	325	337.5	350	362.5
L4	148	173	185.5	198	223	235.5	248	260.5	285.5	298	310.5	335.5	348	360.5	373

L \ n	16	17	18	19	20	21	22	23	24
L1	313	329	345	361	377	393	409	425	441
L2	358	374	390	406	422	438	454	470	486
L3	387.5	400	412.5	437.5	450	462.5	475	500	512.5
L4	398	410.5	423	448	460.5	473	485.5	510.5	523

# Gateway Decentralised System 2

## 5 Port Solenoid Valve



### Series VQC4000

For detailed specifications, Common Precautions and Specific Product Precautions, refer to the **WEB catalogue** or the VQC4000/5000 series catalogue (CAT. EUS11-108).

#### How to Order Manifold

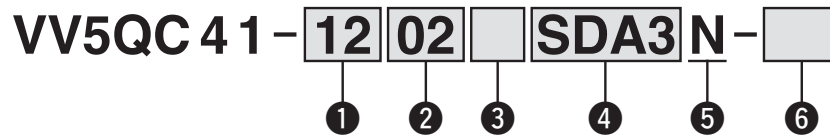

#### 1 Valve stations

Stations	Note
01	1 station
⋮	
12	12 stations
01	1 station
⋮	
16	16 stations

Double wiring

Mixed wiring, Specified layout <sup>Note</sup>  
(Available up to 24 solenoids)

Note) Specified layout: Indicate the wiring specifications on the manifold specification sheet. (Note that 2-position double, 3-position and 4-position valves cannot be used where single wiring has been specified.) In addition, select the option "K".

#### 4 SI Unit (Number of outputs, Max. number of valve stations)

SD0	Without SI Unit
SDA3	32 outputs <sup>Note 1, 3</sup> , 1 to 12 stations (16 stations <sup>Note 2</sup> )

Note 1) Due to the internal wiring of the valve, the maximum number of outputs is 24 points.

Note 2) ( ): Maximum number of stations for mixed single and double wiring.

Note 3) When using the SI Unit with 32 outputs, use the GW Unit compatible with the EX500 Gateway Decentralised System 2 (128 points).

#### 2 Cylinder port size

C6	With Ø 6 One-touch fitting
C8	With Ø 8 One-touch fitting
C10	With Ø 10 One-touch fitting
C12	With Ø 12 One-touch fitting
N7	Ø 1/4" One-touch fitting
N9	Ø 5/16" One-touch fitting
N11	Ø 3/8" One-touch fitting
02	1/4 <sup>Note</sup>
03	3/8 <sup>Note</sup>
B	Bottom ported 1/4 <sup>Note</sup>
CM	Mixed sizes

Note) Compatible with Rc, G, NPT/NPTF.  
Part number displayed is as shown below.

#### 5 SI Unit (Output polarity)

-	(Without SI Unit)
N	Negative common

#### 6 Option

-	None
K <sup>Note</sup>	Special wiring specification (Except double wiring)

Note) When single wiring and double wiring are mixed, specify wiring type of each station on the manifold specification sheet.

#### 3 Thread type

-	Rc
F	G
N	NPT
T	NPTF

**How to Order Valves**

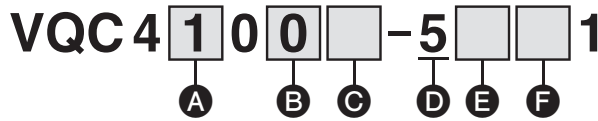

**A Type of actuation**

1	2-position single	4	3-position exhaust centre
2	2-position double	5	3-position pressure centre
3	3-position closed centre	6 <sup>Note)</sup>	3-position double check

Note) For double check type, refer to the **WEB catalogue** or the VQ4000/5000 series catalogue (CAT. EUS11-104).

**B Seal type**

0	Metal seal
1	Rubber seal

**C Function**

— <sup>Note 1)</sup>	Standard (0.95 W)
Y	Low wattage type (0.4 W)
R <sup>Note 2)</sup>	External pilot

\* When multiple symbols are specified, indicate them alphabetically.

Note 1) When the power is energised continuously, refer to "Specific Product Precautions 1" in the **WEB catalogue** or the VQ4000/5000 series catalogue (CAT. EUS11-108).

Note 2) For details about the external pilot type, refer to the **WEB catalogue** or the VQ4000/5000 series catalogue (CAT. EUS11-104). In addition, an external pilot type cannot be combined with the double check spacer.

**D Coil voltage**

5	24 V DC
---	---------

**E Light/surge voltage suppressor**

—	With
E	Without light, with surge voltage suppressor

**F Manual override**

—	Non-locking push (tool required)	
B	Locking push (tool required)	
C	Turn locking (manual)	

**How to Order Manifold Assembly**

**Example**

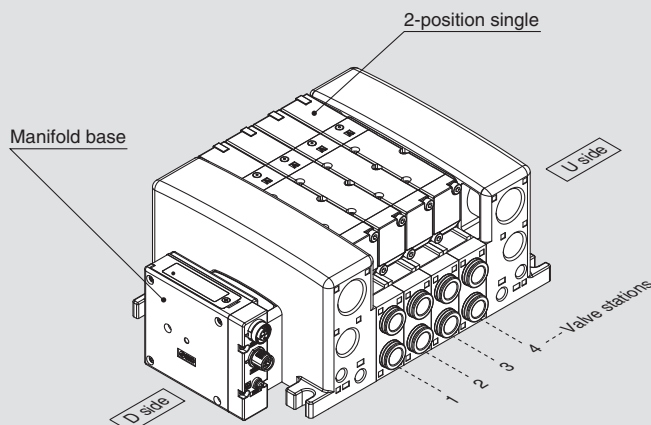

VV5QC41-04C8SDA3N.....1 set (Manifold base part number)  
 \* VQC4100-51.....4 sets (2-position single part number)  
 ↳ The asterisk denotes the symbol for assembly. Prefix it to the part numbers of the valve etc.

- The valve arrangement is numbered as the 1st station from the D side.
- Under the manifold base part number, state the valves to be mounted in order from the 1st station as shown in the figure above. If the arrangement becomes complicated, specify on the manifold specification sheet.

# Series VQC4000

## Dimensions

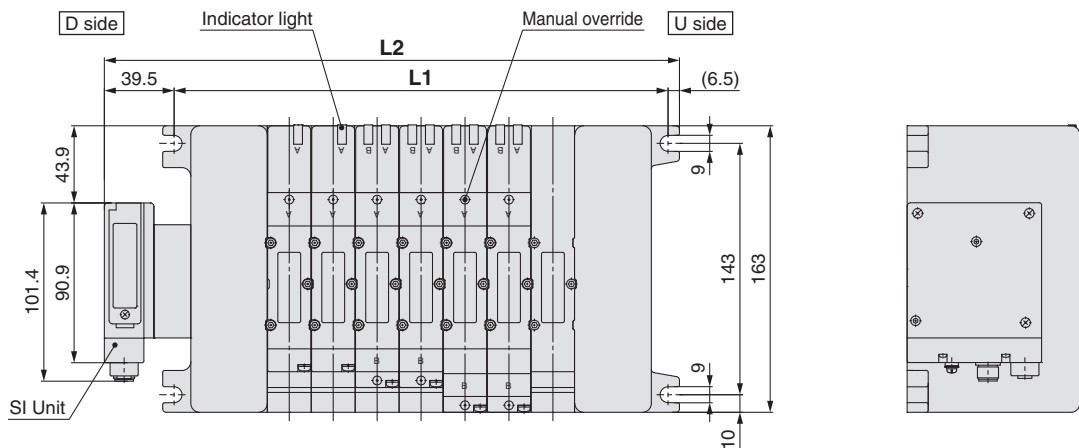
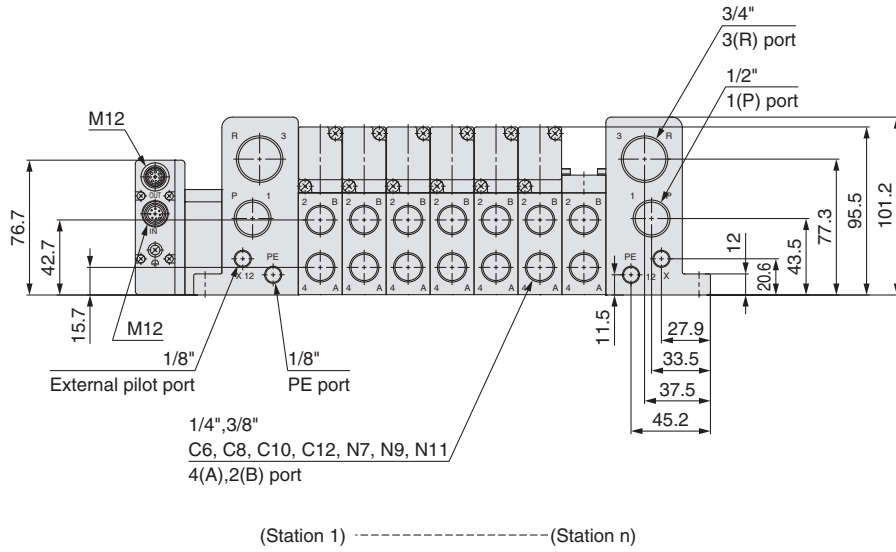

Formula:  $L1 = 25n + 106$ ,  $L2 = 25n + 152$  n: Stations (Maximum 16 stations)

L \ n	1	2	3	4	5	6	7	8	9	10	11	12	13	14	15	16
<b>L1</b>	131	156	181	206	231	256	281	306	331	356	381	406	431	456	481	506
<b>L2</b>	177	202	227	252	277	302	327	352	377	402	427	452	477	502	527	552

# Gateway Decentralised System 2

## 5 Port Solenoid Valve



### Series VQC5000

For detailed specifications, Common Precautions and Specific Product Precautions, refer to the **WEB catalogue** or the VQC4000/5000 series catalogue (CAT. EUS11-108).

#### How to Order Manifold

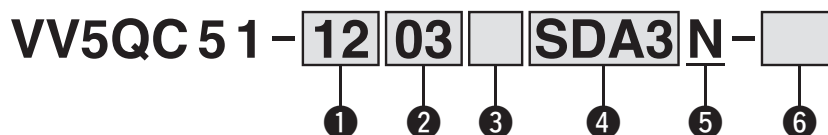

#### 1 Valve stations

	Stations	Note
01	1 station	Double wiring
⋮	⋮	
12	12 stations	Mixed wiring, Specified layout <sup>Note)</sup> (Available up to 24 solenoids)
01	1 station	
⋮	⋮	
16	16 stations	

Note) Specified layout: Indicate the wiring specifications on the manifold specification sheet. (Note that 2-position double, 3-position and 4-position valves cannot be used where single wiring has been specified.) In addition, select the option "K".

#### 2 Cylinder port size

03	3/8 <sup>Note)</sup>
04	1/2 <sup>Note)</sup>
B	Bottom ported 1/4 <sup>Note)</sup>
CM	Mixed sizes

Note) Compatible with Rc, G, NPT/NPTF.  
Part number displayed is as shown below.

#### 3 Thread type

—	Rc
F	G
N	NPT
T	NPTF

#### 4 SI Unit (Number of outputs, Max. number of valve stations)

SD0	Without SI Unit
SDA3	32 outputs <sup>Note 1, 3)</sup> , 1 to 12 stations (16 stations <sup>Note 2)</sup> )

Note 1) Due to the internal wiring of the valve, the maximum number of outputs is 24 points.

Note 2) ( ): Maximum number of stations for mixed single and double wiring.

Note 3) When using the SI Unit with 32 outputs, use the GW Unit compatible with the EX500 Gateway Decentralised System 2 (128 points).

#### 5 SI Unit (Output polarity)

—	(Without SI Unit)
N	Negative common

#### 6 Option

—	None
K <sup>Note)</sup>	Special wiring specification (Except double wiring).

Note) When single wiring and double wiring are mixed, specify wiring type of each station on the manifold specification sheet.

## How to Order Valves

VQC5 **1** **0** **0** **□** - **5** **□** **□** **1**

A      B      C      D      E      F

### A Type of actuation

<b>1</b>	2-position single	<b>4</b>	3-position exhaust centre
<b>2</b>	2-position double	<b>5</b>	3-position pressure centre
<b>3</b>	3-position closed centre	<b>6</b> (Note)	3-position double check

Note) For double check type, refer to the **WEB catalogue** or the VQ4000/5000 series catalogue (CAT. EUS11-104).

### B Seal type

<b>0</b>	Metal seal
<b>1</b>	Rubber seal

### C Function

— (Note 1)	Standard (0.95 W)
<b>Y</b>	Low wattage type (0.4 W)
<b>R</b> (Note 2)	External pilot

\* When multiple symbols are specified, indicate them alphabetically.

Note 1) When the power is energised continuously, refer to "Specific Product Precautions 1" in the **WEB catalogue** or the VQC4000/5000 series catalogue (CAT. EUS11-108).

Note 2) For details about the external pilot type, refer to the **WEB catalogue** or the VQ4000/5000 series catalogue (CAT. EUS11-104). In addition, an external pilot type cannot be combined with the double check spacer.

### D Coil voltage

<b>5</b>	24 V DC
----------	---------

### E Light/surge voltage suppressor

—	With
<b>E</b>	Without light, with surge voltage suppressor

### F Manual override

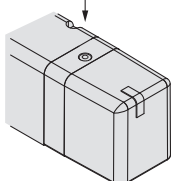
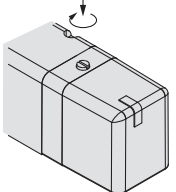
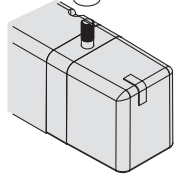
—	Non-locking push (tool required)	
<b>B</b>	Push-turn locking (tool required)	
<b>C</b>	Turn locking (manual)	

## How to Order Manifold Assembly

**Example**

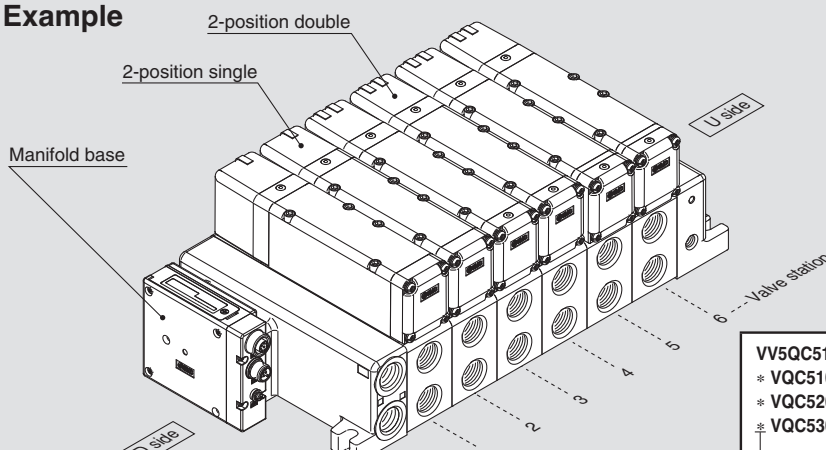

Manifold base

2-position single

2-position double

D side

U side

6 Valve stations

VV5QC51-0603SDA3N..... 1 set

\* VQC5100-51..... 2 sets (2-position single part number)

\* VQC5200-51..... 2 sets (2-position double part number)

\* VQC5300-51..... 3 sets (3-position closed centre part number)

→ The asterisk denotes the symbol for assembly. Prefix it to the part numbers of the valve etc.

- The valve arrangement is numbered as the 1st station from the D side.
- Under the manifold base part number, state the valves to be mounted in order from the 1st station as shown in the figure above. If the arrangement becomes complicated, specify on the manifold specification sheet.

## Dimensions

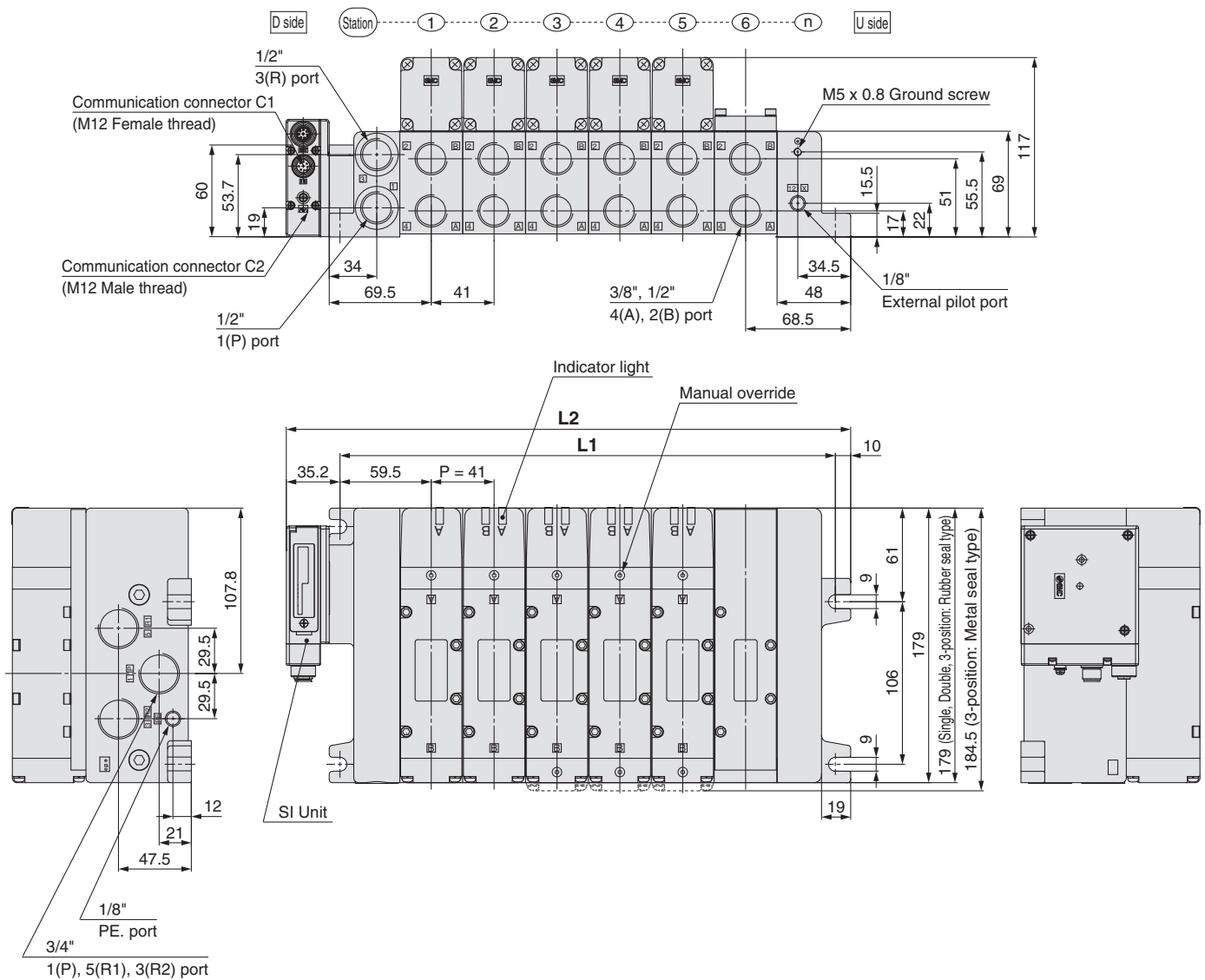

Formula:  $L1 = 41n + 77$ ,  $L2 = 41n + 122n$ : Stations (Maximum 12 stations)

n	1	2	3	4	5	6	7	8	9	10	11	12
L1	118	159	200	241	282	323	364	405	446	487	528	569
L2	163.2	204.2	245.2	286.2	327.2	368.2	409.2	450.2	491.2	532.2	573.2	614.2

# Gateway Decentralised System 2

## 5 Port Solenoid Valve



### Series S0700

For detailed specifications, Common Precautions and Specific Product Precautions, refer to the **WEB catalogue** or the S0700 series catalogue (CAT. EUS11-88).

#### How to Order Manifold

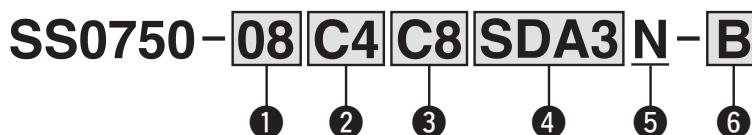

#### 1 Valve stations

	Stations	Note
<b>01</b>	1 station	Double wiring
⋮	⋮	
<b>16</b>	16 stations	Mixed wiring, Specified layout <sup>Note)</sup> (Available up to 32 solenoids)
<b>01</b>	1 station	
⋮	⋮	
<b>24</b>	24 stations	

Note) Specified layout: Indicate the wiring specifications on the manifold specification sheet. (Note that 2-position double, 3-position and 4-position valves cannot be used where single wiring has been specified.) In addition, select the option "K".

#### 4 SI Unit (Number of outputs, Max. number of valve stations)

SD0	Without SI Unit
<b>SDA3</b>	32 outputs <sup>Note 1, 3)</sup> , 1 to 16 stations (24 stations <sup>Note 2)</sup> )

Note 1) 16 outputs can be set by switching the built-in setting switch.  
 Note 2) ( ): Maximum number of stations for mixed single and double wiring.  
 Note 3) When using the SI Unit with 32 outputs, use the GW Unit compatible with the EX500 Gateway Decentralised System 2 (128 points).

#### 2 A, B port size

##### Metric size

<b>C2</b>	Ø 2 One-touch fitting
<b>C3</b>	Ø 3.2 One-touch fitting
<b>C4</b>	Ø 4 One-touch fitting
<b>CM</b> <sup>Note)</sup>	Mixed sizes and with port plug

##### Inch size

<b>N1</b>	Ø 1/8" One-touch fitting
<b>N3</b>	Ø 5/32" One-touch fitting
<b>NM</b> <sup>Note)</sup>	Mixed sizes and with port plug

Note) Indicate the sizes on the manifold specification sheet.

#### 5 SI Unit (Output polarity)

-	(Without SI Unit)
<b>N</b>	Negative common

#### 6 Option

-	None
<b>B</b> <sup>Note 1)</sup>	With back pressure check valve (All stations)
<b>D</b>	With DIN bracket, DIN rail with standard length
<b>D0</b>	With DIN bracket, without DIN rail
<b>D□</b> <sup>Note 2)</sup>	With DIN bracket, DIN rail for □ stations
<b>K</b> <sup>Note 3)</sup>	Special wiring specification (Except double wiring)
<b>N</b>	With name plate
<b>R</b> <sup>Note 4)</sup>	External pilot
<b>S</b>	Built-in silencer

\* When multiple symbols are specified, indicate them alphabetically. Example) "BKN"

Note 1) When a back pressure check valve is used only for specified station, specify the back pressure check valve part number, and specify the station number to which the valve is mounted, on the manifold specification sheet.

Note 2) □: Specify a longer rail than the length of valve stations.  
 Example) "D08"

In this case, the valves will be mounted on the DIN rail for 8 stations, regardless of the number of manifold stations.

Note 3) When single wiring and double wiring are mixed, specify wiring type of each station on the manifold specification sheet.

Note 4) For external pilot option "-R", indicate the external pilot specification "R" for the applicable valves as well.

#### 3 P, R port size

##### Metric size

-	Ø 8 One-touch fitting <sup>Note)</sup>
<b>C6</b>	Ø 6 One-touch fitting
<b>C8</b>	Ø 8 One-touch fitting

##### Inch size

<b>N7</b>	Ø 1/4" One-touch fitting
<b>N9</b>	Ø 5/16" One-touch fitting

Note) When A and B ports are inch size, the One-touch fitting will be changed to Ø 5/16".



## How to Order Valves

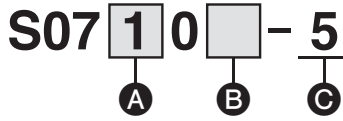

### A Type of actuation

<b>1</b>	2-position single
<b>2</b>	2-position double
<b>A</b> (Note)	4-position dual 3-port (N.C. + N.C.) [Exhaust centre]
<b>B</b> (Note)	4-position dual 3-port (N.O. + N.O.) [Pressure centre]
<b>C</b> (Note)	4-position dual 3-port (N.C. + N.O.)

Note) For 4-position dual 3-port, select “—” internal pilot.

### B Function

—	Internal pilot
<b>R</b> (Note)	External pilot

Note) For external pilot, select “1” 2-position single or “2” 2-position double.

### C Rated voltage

<b>5</b>	24 V DC
----------	---------

## How to Order Manifold Assembly

### Example

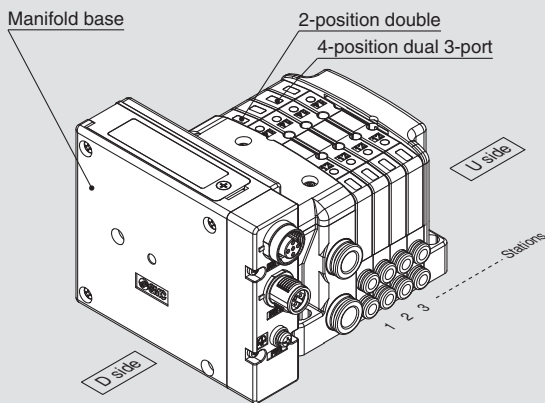

SS0750-04C4SDA3...1 set (Manifold base part number)  
 \* S0720-5.....2 sets (2-position double part number)  
 \* S07A0-5.....2 sets (4-position dual 3-port number)  
 ↳ The asterisk denotes the symbol for assembly.  
 Prefix it to the part numbers of the valve etc.

- The valve arrangement is numbered as the 1st station from the D side.
- Under the manifold base part number, state the valves to be mounted in order from the 1st station as shown in the figure above. If the arrangement becomes complicated, specify on the manifold specification sheet.

# Series S0700

## Dimensions

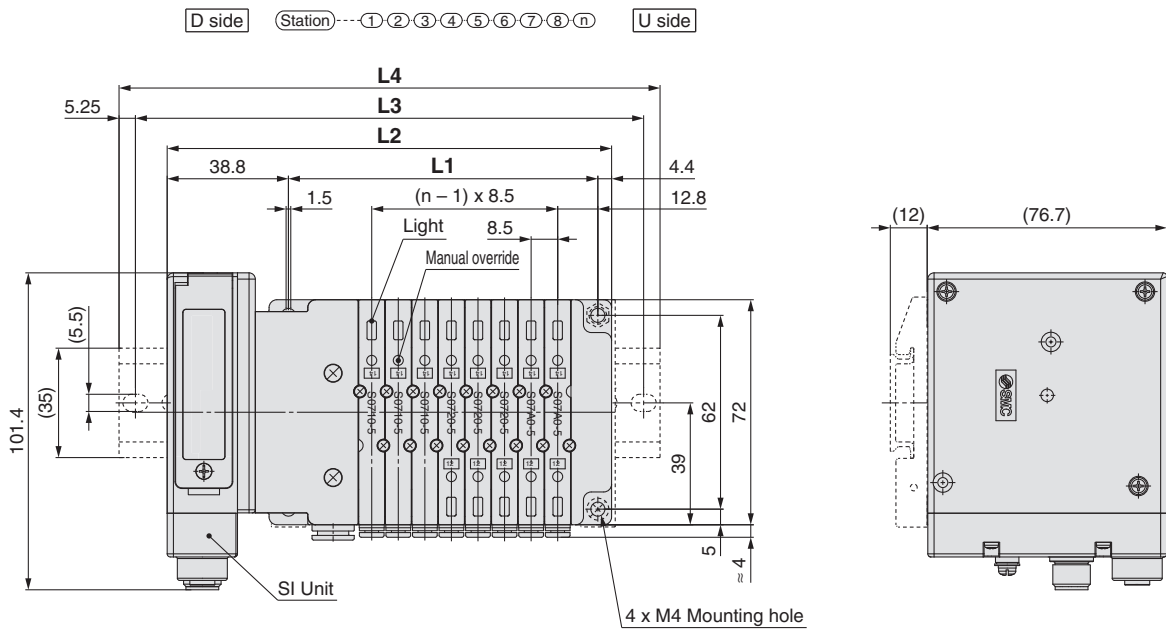
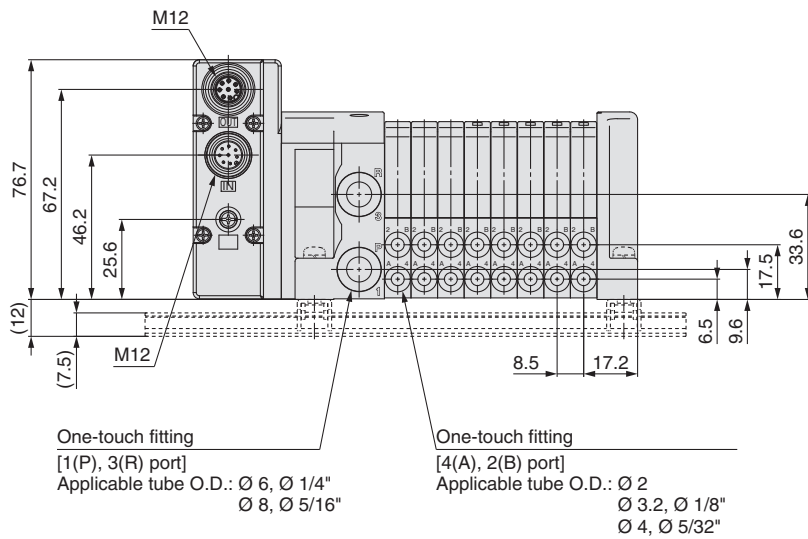

## Dimensions

Formula:  $L1 = 8.5n + 31$ ,  $L2 = 8.5n + 74$  n: Stations (Maximum 24 stations)

L \ n	1	2	3	4	5	6	7	8	9	10	11	12	13	14	15	16
L1	39.5	48	56.5	65	73.5	82	90.5	99	107.5	116	124.5	133	141.5	150	158.5	167
L2	82.5	91	99.5	108	116.5	125	133.5	142	150.5	159	167.5	176	184.5	193	201.5	210
L3	112.5	112.5	125	137.5	137.5	150	162.5	162.5	175	187.5	187.5	200	212.5	212.5	225	237.5
L4	123	123	135.5	148	148	160.5	173	173	185.5	198	198	210.5	223	223	235.5	248

L \ n	17	18	19	20	21	22	23	24
L1	175.5	184	192.5	201	209.5	218	226.5	235
L2	218.5	227	235.5	244	252.5	261	269.5	278
L3	250	250	262.5	275	275	287.5	300	300
L4	260.5	260.5	273	285.5	285.5	298	310.5	310.5

# Gateway Decentralised System 2

## 5 Port Solenoid Valve

### Series SV1000/2000/3000



For detailed specifications, Common Precautions and Specific Product Precautions, refer to the **WEB catalogue** or the SV series catalogue (CAT. EUS11-81).

#### How to Order Manifold



#### 1 Series

1	SV1000
2	SV2000
3	SV3000

#### 2 SI Unit (Number of outputs, Output polarity, Max. number of valve stations)

0	Without SI Unit
A3N	32 outputs <sup>Note 1, 3)</sup> , Negative common, 1 to 16 stations (20 stations <sup>Note 2)</sup> )

Note 1) 16 outputs can be set by switching the built-in setting switch.  
 Note 2) ( ): Maximum number of stations for mixed single and double wiring.  
 Note 3) When using the SI Unit with 32 outputs, use the GW Unit compatible with the EX500 Gateway Decentralised System 2 (128 points).

#### 3 Valve stations

Stations	Note
02	2 stations Double wiring <sup>Note 1)</sup>
⋮	
16	
02	2 stations Mixed wiring, Specified layout <sup>Note 2)</sup> (Available up to 32 solenoids)
⋮	
20	

Note 1) Double wiring: single, double, 3-position and 4-position valves can be used on all manifold stations.  
 Use of a single solenoid will result in an unused control signal. If this is not desired, order with a specified layout.  
 Note 2) Specified layout: Indicate the wiring specifications on the manifold specification sheet. (Note that double, 3-position and 4-position valves cannot be used where single wiring has been specified.)

#### 4 P, E port entry

U	U side (2 to 10 stations)
D	D side (2 to 10 stations)
B	Both sides (2 to 20 stations)

#### 5 SUP/EXH block assembly

—	Internal pilot
S	Internal pilot, Built-in silencer <sup>Note)</sup>
R	External pilot
RS	External pilot, Built-in silencer <sup>Note)</sup>

Note) When the built-in silencer type is used, keep the exhaust port from coming in direct contact with water or other liquids.

#### 6 A, B port size

##### Metric size

	A, B port	P, E port	Applicable series
C3	Ø 3.2 One-touch fitting	Ø 8 One-touch fitting	SV1000
C4	Ø 4 One-touch fitting		
C6	Ø 6 One-touch fitting		
C4	Ø 4 One-touch fitting	Ø 10 One-touch fitting	SV2000
C6	Ø 6 One-touch fitting		
C8	Ø 8 One-touch fitting		
C6	Ø 6 One-touch fitting	Ø 12 One-touch fitting	SV3000
C8	Ø 8 One-touch fitting		
C10	Ø 10 One-touch fitting		
M <sup>Note)</sup>	A, B port mixed		

##### Inch size

	A, B port	P, E port	Applicable series
N1	Ø 1/8" One-touch fitting	Ø 5/16" One-touch fitting	SV1000
N3	Ø 5/32" One-touch fitting		
N7	Ø 1/4" One-touch fitting		
N3	Ø 5/32" One-touch fitting	Ø 3/8" One-touch fitting	SV2000
N7	Ø 1/4" One-touch fitting		
N9	Ø 5/16" One-touch fitting		
N7	Ø 1/4" One-touch fitting	Ø 3/8" One-touch fitting	SV3000
N9	Ø 5/16" One-touch fitting		
N11	Ø 3/8" One-touch fitting		
M <sup>Note)</sup>	A, B port mixed		

Note) Indicate the sizes on the manifold specification sheet.  
 \* The X and PE port size of external pilot type [R, RS] are Ø 4 (mm) or Ø 5/32" (inch) for the SV1000/2000 series, and Ø 6 (mm) or Ø 1/4" (inch) for the SV3000 series.

#### 7 Mounting

—	Direct mounting
D	With DIN bracket, DIN rail with standard length
D0	With DIN bracket, without DIN rail
D3 <sup>Note)</sup>	With DIN bracket, DIN rail for 3 stations
⋮	⋮
D20 <sup>Note)</sup>	With DIN bracket, DIN rail for 20 stations

Note) Specify a longer rail than the length of valve stations.  
 \* If the DIN rail must be mounted without an SI Unit, select "D0" and order the DIN rail separately. Refer to L3 of the dimensions for the DIN rail length. For the DIN rail part number, refer to the **WEB catalogue** or the SV series catalogue (CAT. EUS11-81).

Gateway Decentralised System 2

SV

VQC

S0700

SV

# Series SV1000/2000/3000

## How to Order Valves

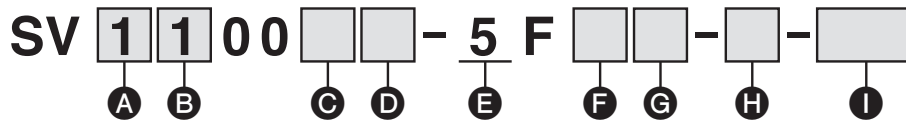

### A Series

1	SV1000
2	SV2000
3	SV3000

### B Type of actuation

1	2-position single
2	2-position double
3	3-position closed centre
4	3-position exhaust centre
5	3-position pressure centre
<b>A</b> (Note)	4-position dual 3-port valve (N.C./N.C.)
<b>B</b> (Note)	4-position dual 3-port valve (N.O./N.O.)
<b>C</b> (Note)	4-position dual 3-port valve (N.C./N.O.)

Note) Select the SV1000 or SV2000 series for the 4-position dual 3-port valve.

\* Select the internal pilot type for the 4-position dual 3-port valve.

### C Pilot type

—	Internal pilot
R	External pilot

### D Back pressure check valve

—	None
K	Built-in

\* Built-in back pressure check valve type is applicable to the SV1000 series only.

\* The product with a back pressure check valve is not available for 3-position valves.

\* Refer to the **WEB catalogue** for built-in back pressure check valve type.

### E Rated voltage

5	24 V DC
---	---------

### F Light/surge voltage suppressor

U	With light/surge voltage suppressor
R	Without light, with surge voltage suppressor

### G Manual override

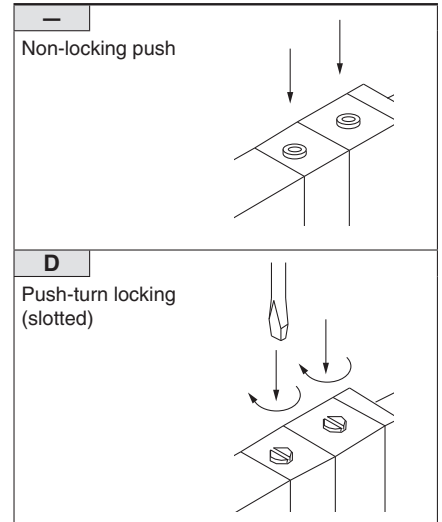

### H Manifold block

If stations are to be added, order the product with manifold block.

(For details, refer to the **WEB catalogue**.)

### I Made to Order

—	—
X90	Main valve fluororubber specification (For details, refer to the <b>WEB catalogue</b> .)

## How to Order Manifold Assembly

### Example

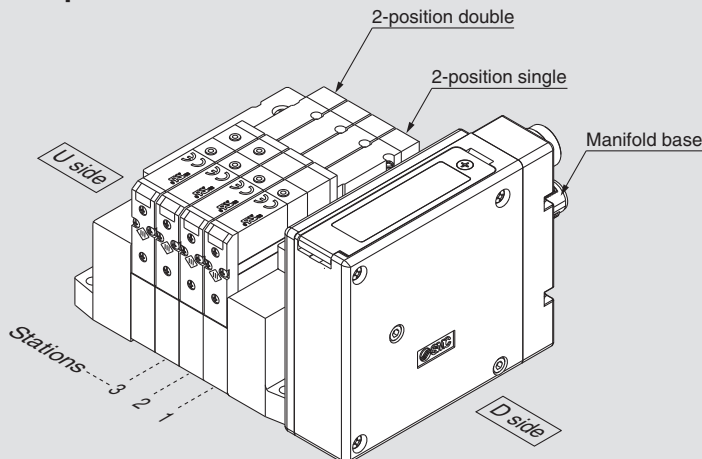

SS5V1-W10S1A3ND-04B-C6.....1 set (Manifold base part number)  
 \* SV1100-5FU.....2 sets (2-position single part number)  
 \* SV1200-5FU.....2 sets (2-position double part number)

The asterisk denotes the symbol for assembly.  
 Prefix it to the part numbers of the valve etc.

- The valve arrangement is numbered as the 1st station from the D side.
- Under the manifold base part number, state the valves to be mounted in order from the 1st station as shown in the figure above. If the arrangement becomes complicated, specify on the manifold specification sheet.

## Dimensions

Tie-rod Base Series SV1000

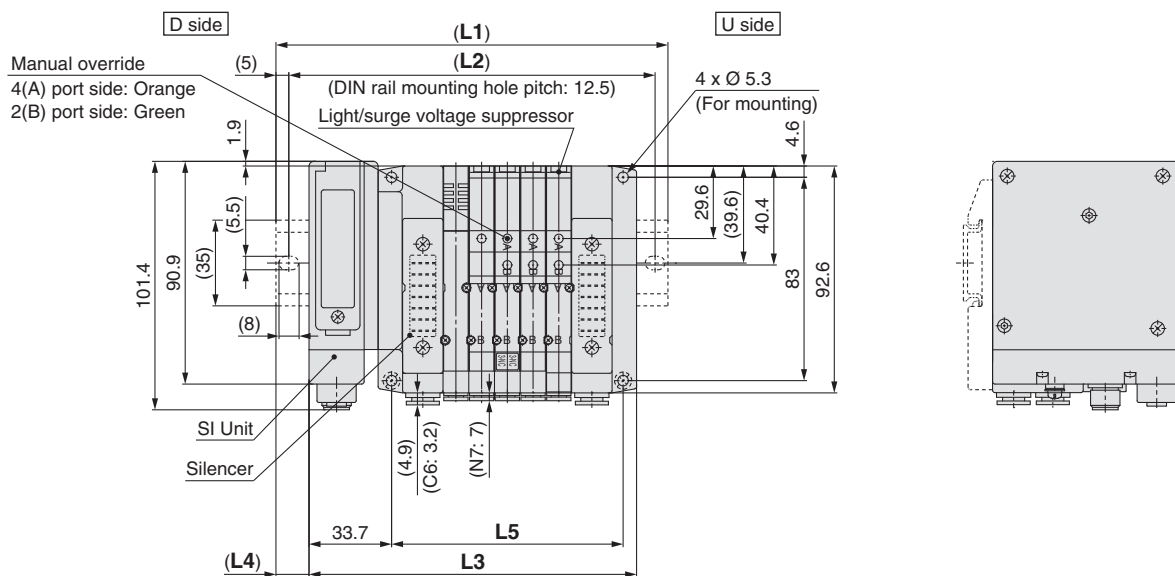
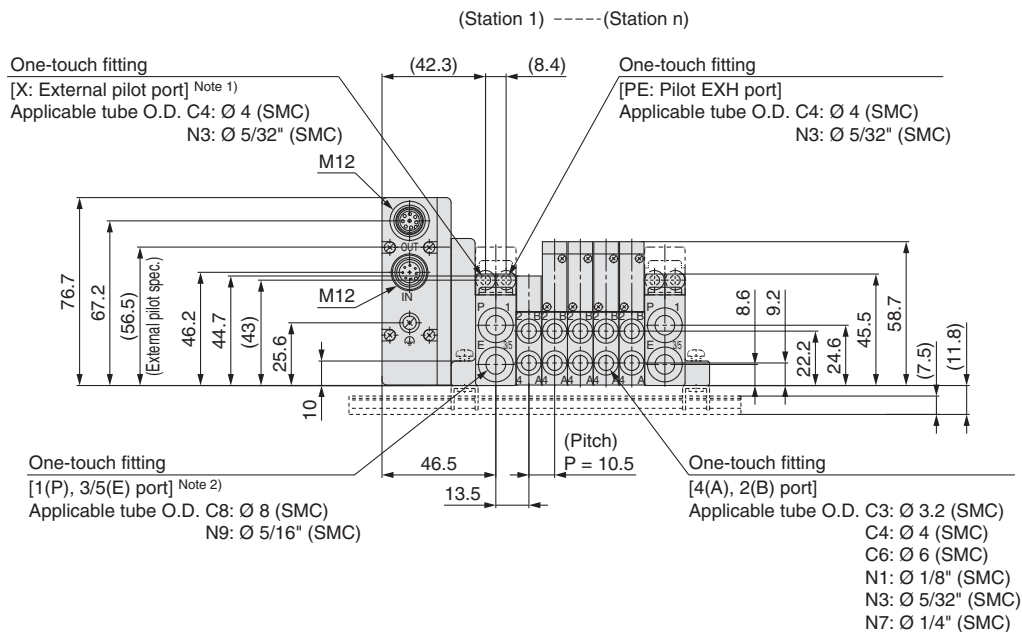

Note 1) External pilot port positions and silencer discharge port positions are the same as P, E port outlet positions.  
 Note 2) When P, E port outlets are indicated on the U side or D side, the P, E ports on the opposite side are plugged.

### L: DIN Rail Overall Length

n: Stations

L \ n	2	3	4	5	6	7	8	9	10	11	12	13	14	15	16	17	18	19	20
L1	135.5	148	148	160.5	173	185.5	198	210.5	210.5	223	235.5	248	260.5	273	273	285.5	298	310.5	323
L2	125	137.5	137.5	150	162.5	175	187.5	200	200	212.5	225	237.5	250	262.5	262.5	275	287.5	300	312.5
L3	102.2	112.7	123.2	133.7	144.2	154.7	165.2	175.7	186.2	196.7	207.2	217.7	228.2	238.7	249.2	259.7	270.2	280.7	291.2
L4	16.5	17.5	12.5	13.5	14.5	15.5	16.5	17.5	12	13	14	15	16	17	12	13	14	15	16
L5	63	73.5	84	94.5	105	115.5	126	136.5	147	157.5	168	178.5	189	199.5	210	220.5	231	241.5	252

Gateway Decentralised System 2  
SY  
VQC  
S0700  
SV

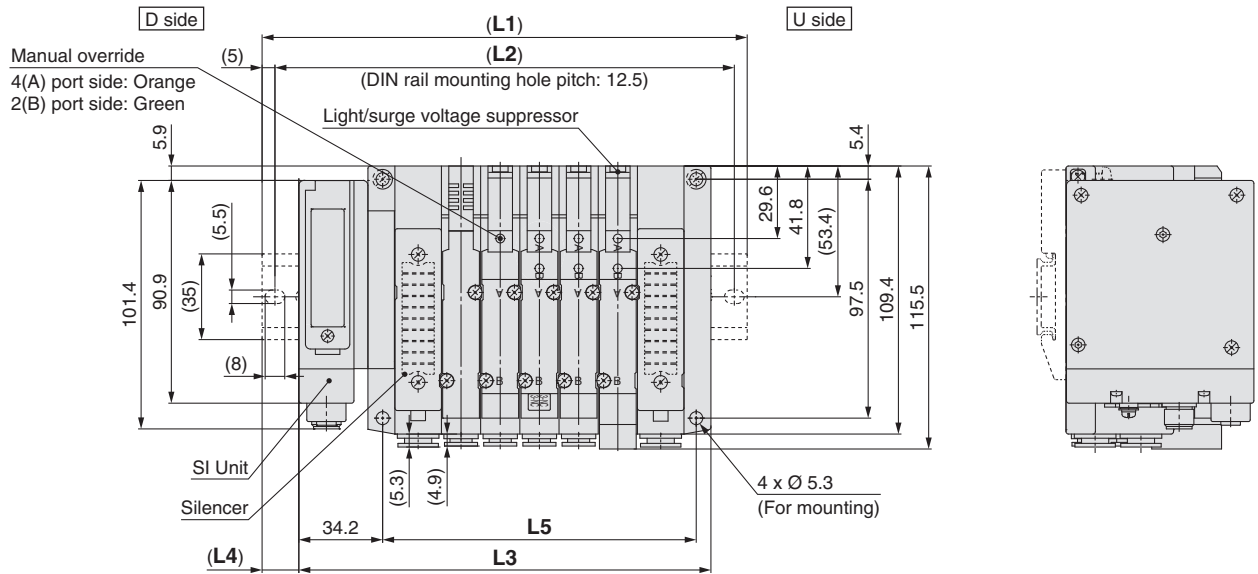
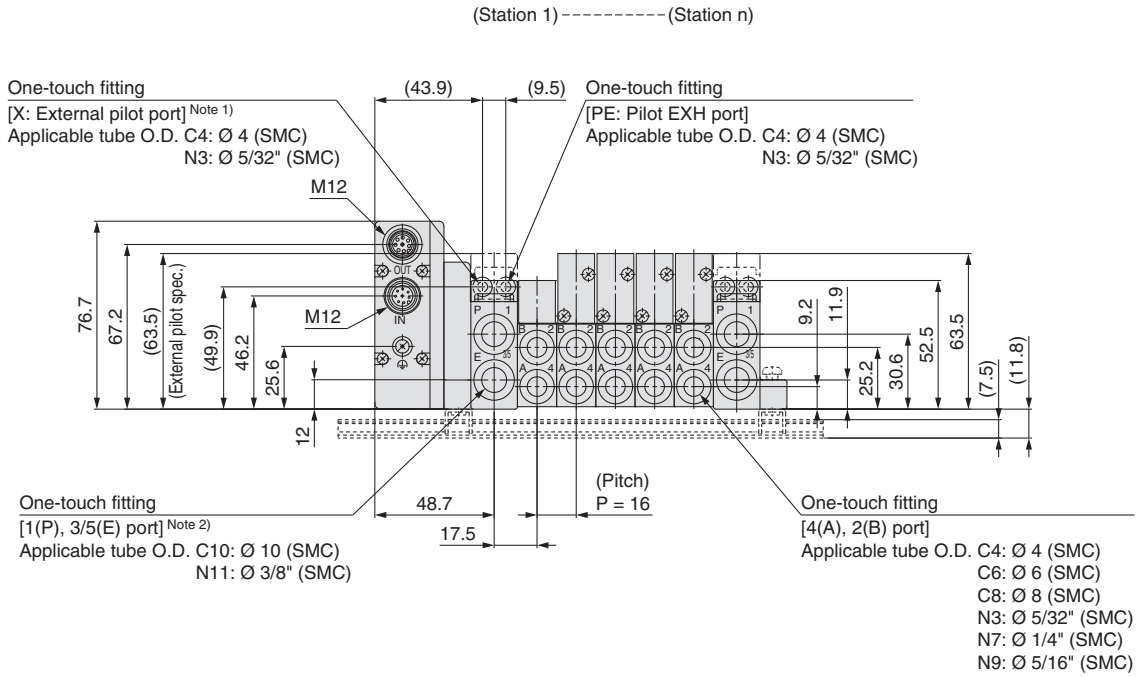

Note 1) External pilot port positions and silencer discharge port positions are the same as P, E port outlet positions.  
Note 2) When P, E port outlets are indicated on the U side or D side, the P, E ports on the opposite side are plugged.

### L: DIN Rail Overall Length

n: Stations

L \ n	2	3	4	5	6	7	8	9	10	11	12	13	14	15	16	17	18	19	20
<b>L1</b>	148	160.5	185.5	198	210.5	235.5	248	260.5	273	298	310.5	323	335.5	360.5	373	385.5	410.5	423	435.5
<b>L2</b>	137.5	150	175	187.5	200	225	237.5	250	262.5	287.5	300	312.5	325	350	362.5	375	400	412.5	425
<b>L3</b>	120.2	136.2	152.2	168.2	184.2	200.2	216.2	232.2	248.2	264.2	280.2	296.2	312.2	328.2	344.2	360.2	376.2	392.2	408.2
<b>L4</b>	14	12	16.5	15	13	17.5	16	14	12.5	17	15	13.5	11.5	16	14.5	12.5	17	15.5	13.5
<b>L5</b>	80	96	112	128	144	160	176	192	208	224	240	256	272	288	304	320	336	352	368

## Dimensions

Tie-rod Base Series SV3000

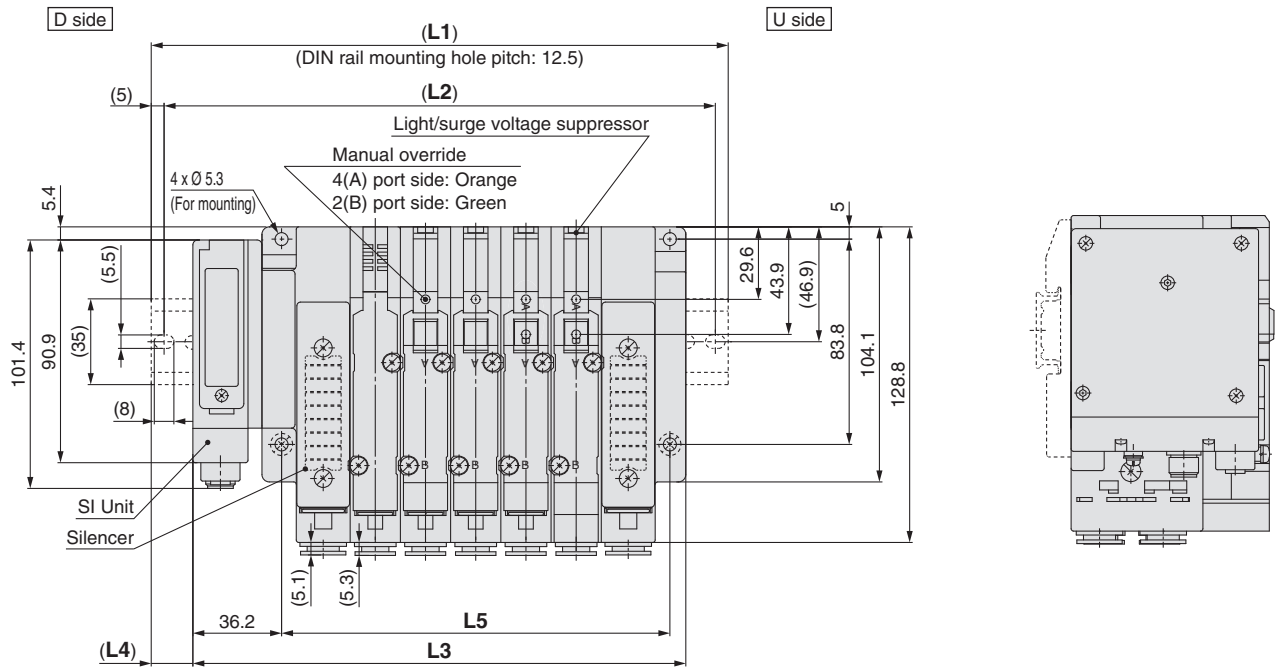
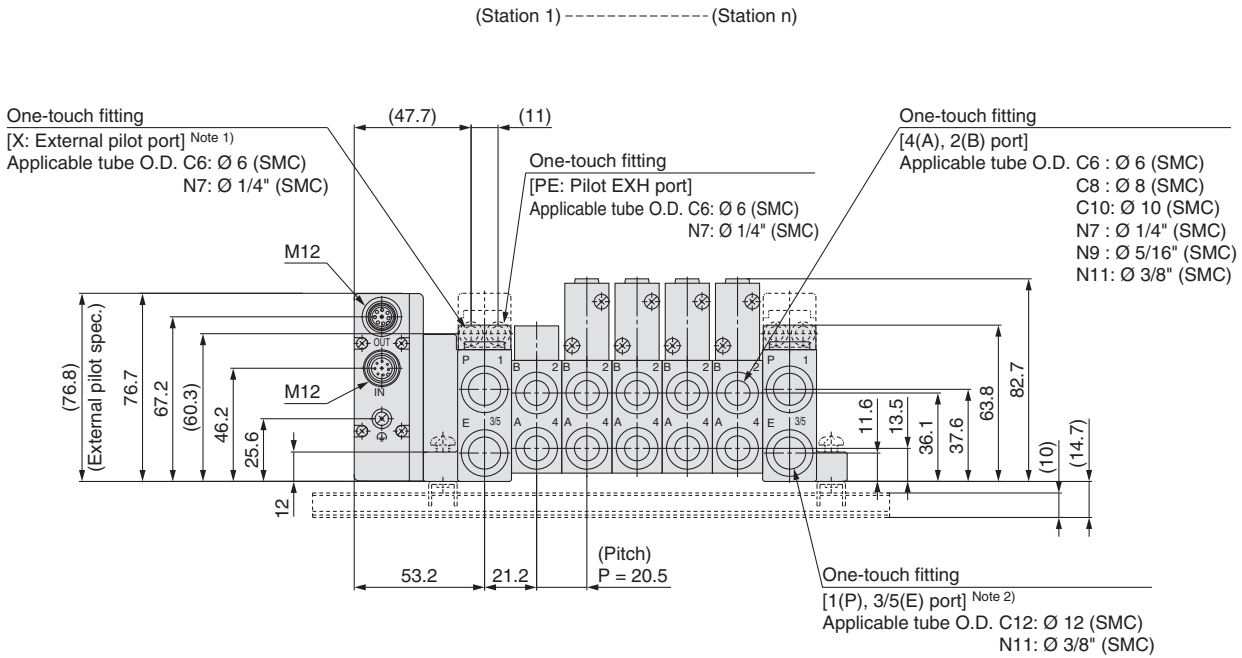

Note 1) External pilot port positions and silencer discharge port positions are the same as P, E port outlet positions.  
Note 2) When P, E port outlets are indicated on the U side or D side, the P, E ports on the opposite side are plugged.

### L: DIN Rail Overall Length

n: Stations

L \ n	2	3	4	5	6	7	8	9	10	11	12	13	14	15	16	17	18	19	20
<b>L1</b>	173	185.5	210.5	235.5	248	273	298	310.5	335.5	348	373	398	410.5	435.5	460.5	473	498	523	535.5
<b>L2</b>	162.5	175	200	225	237.5	262.5	287.5	300	325	337.5	362.5	387.5	400	425	450	462.5	487.5	512.5	525
<b>L3</b>	139.7	160.2	180.7	201.2	221.7	242.2	262.7	283.2	303.7	324.2	344.7	365.2	385.7	406.2	426.7	447.2	467.7	488.2	508.7
<b>L4</b>	16.5	12.5	15	17	13	15.5	17.5	13.5	16	12	14	16.5	12.5	14.5	17	13	15	17.5	13.5
<b>L5</b>	97	117.5	138	158.5	179	199.5	220	240.5	261	281.5	302	322.5	343	363.5	384	404.5	425	445.5	466

Type 10  
Side Ported

Type 11  
Bottom Ported

# Gateway Decentralised System

## 5 Port Solenoid Valve

### Series SY3000/5000/7000



For detailed specifications, Common Precautions and Specific Product Precautions, refer to the **WEB catalogue** or the SY series catalogue (CAT. EUS11-103).

### How to Order Manifold

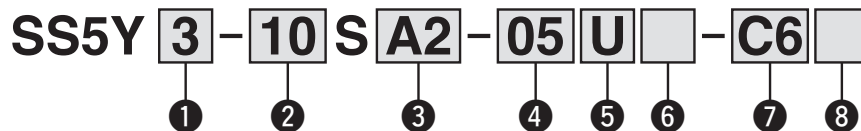

#### 1 Series

3	SY3000
5	SY5000
7	SY7000

\* For mixed mounting, refer to the **WEB catalogue** or the SY series catalogue (CAT. EUS11-103).

#### 2 Type

10	Side ported
11	Bottom ported <sup>Note)</sup>

Note) The SY5000 manifold base is used for the bottom ported of the SY3000. When ordering, refer to the **WEB catalogue** or the SY series catalogue (CAT. EUS11-103).

\* When mixing top ported configurations, select from page 51.

In this case, use caution as there is also output on the A and B port on base side. Specify on a manifold specification sheet if plugs are required on the A and B port on base side.

#### 3 SI Unit (Number of outputs, Output polarity, Max. number of valve stations)

A2	16 outputs, Positive common <sup>Note 1)</sup> , 1 to 8 stations (16 stations) <sup>Note 2)</sup>
A2N	16 outputs, Negative common <sup>Note 1)</sup> , 1 to 8 stations (16 stations) <sup>Note 2)</sup>

Note 1) Ensure a match with the common specification of the valve to be used.

Note 2) ( ): Maximum number of stations for single wiring.

#### 4 Valve stations

Stations	Note
02	2 stations
⋮	
08	8 stations
⋮	
02	2 stations
⋮	
16	16 stations

Note 1) Double wiring: 2-position single, double, 3-position and 4-position valves can be used on all manifold stations.

Use of a 2-position single solenoid will result in an unused control signal. If this is not desired, order with a specified layout.

Note 2) Specified layout: Indicate the wiring specifications on the manifold specification sheet. (Note that 2-position double, 3-position and 4-position valves cannot be used where single wiring has been specified.)

Note 3) For the product without the SI Unit (S0), note the maximum number of solenoids of the SI Unit that will be mounted. If the layout is specified, indicate it on the manifold specification sheet.

\* This also includes the number of blanking plate assembly.

### How to Order Manifold Assembly

#### Example

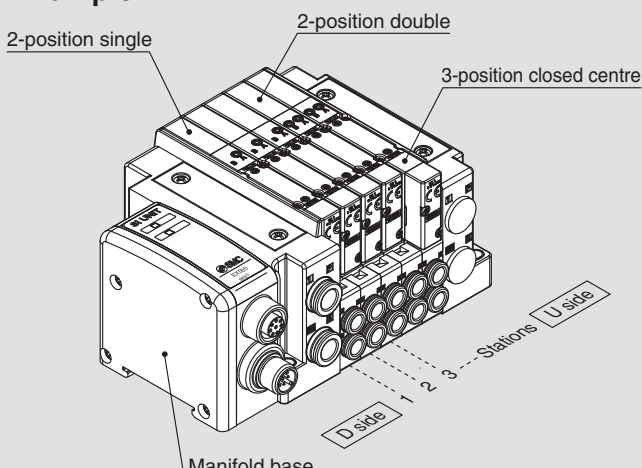

SS5Y3-10SA2-05D-C6.....1 set (Manifold base part number)  
 \* SY3100-5U1.....3 sets (2-position single part number)  
 \* SY3200-5U1.....1 set (2-position double part number)  
 \* SY3300-5U1.....1 set (3-position closed centre part number)

The asterisk denotes the symbol for assembly.  
 Prefix it to the part numbers of the valve etc.

- The valve arrangement is numbered as the 1st station from the D side.
- Under the manifold base part number, state the valves to be mounted in order from the 1st station as shown in the figure above. If the arrangement becomes complicated, specify on the manifold specification sheet.

#### 5 P, E port entry

U	U side (2 to 10 stations)
D	D side (2 to 10 stations)
B	Both sides (2 to 16 stations)

#### 6 SUP/EXH block assembly

—	Internal pilot
S	Internal pilot, Built-in silencer <sup>Note 1) 2)</sup>
R	External pilot

Note 1) 3/5(E) port is plugged for the built-in silencer type.

Note 2) When built-in silencer type is used, keep the exhaust port from coming in direct contact with water or other liquids.



**7 A, B port size (Metric/One-touch fitting)**

	A, B port	Type 10/Side Ported			Type 11/Bottom Ported	
		SY3000	SY5000	SY7000	SY5000	SY7000
<b>C2</b>	Ø 2	●	—	—	—	—
<b>C3</b>	Ø 3.2	●	—	—	—	—
<b>C4</b>	Ø 4	●	●	—	●	—
<b>C6</b>	Ø 6	●	●	●	●	●
<b>C8</b>	Ø 8	—	●	●	●	●
<b>C10</b>	Ø 10	—	—	●	—	●
<b>C12</b>	Ø 12	—	—	●	—	●
<b>CM (Note 1)</b>	Mixed sizes	●	●	●	●	●
<b>L4</b> <b>L6</b> <b>L8</b> <b>L10</b> <b>L12</b>	Upward	Ø 4	●	●	—	—
		Ø 6	●	●	●	—
		Ø 8	—	●	●	—
		Ø 10	—	—	●	—
		Ø 12	—	—	●	—
		Mixed sizes	●	●	●	—
<b>B4</b> <b>B6</b> <b>B8</b> <b>B10</b> <b>B12</b>	Downward	Ø 4	●	●	—	—
		Ø 6	●	●	●	—
		Ø 8	—	●	●	—
		Ø 10	—	—	●	—
		Ø 12	—	—	●	—
		Mixed sizes	●	●	●	—
<b>LM (Note 1)</b>	Mixed sizes	●	●	●	—	—
<b>P, E port (Note 3)</b>		Ø 8	Ø 10	Ø 12	Ø 10	Ø 12

**A, B port size (Inch/One-touch fitting)**

	A, B port	Type 10/Side Ported			Type 11/Bottom Ported	
		SY3000	SY5000	SY7000	SY5000	SY7000
<b>N1</b>	Ø 1/8"	●	—	—	—	—
<b>N3</b>	Ø 5/32"	●	●	—	●	—
<b>N7</b>	Ø 1/4"	●	●	●	●	●
<b>N9</b>	Ø 5/16"	—	●	●	●	●
<b>N11</b>	Ø 3/8"	—	—	●	—	●
<b>CM (Note 1)</b>	Mixed sizes	●	●	●	●	●
<b>LN3</b> <b>LN7</b> <b>LN9</b>	Upward	Ø 5/32"	●	—	—	—
		Ø 1/4"	●	●	—	—
		Ø 5/16"	—	●	—	—
<b>LN11</b> <b>BN3</b> <b>BN7</b> <b>BN9</b> <b>BN11</b>	Downward	Ø 3/8"	—	—	●	—
		Ø 5/32"	●	—	—	—
		Ø 1/4"	●	●	—	—
<b>BN9</b> <b>BN11</b>	Downward	Ø 5/16"	—	●	—	—
		Ø 3/8"	—	—	●	—
<b>LM (Note 1)</b>	Mixed sizes	●	●	●	—	—
<b>P, E port (Note 3)</b>		Ø 5/16"	Ø 3/8"	Ø 1/2"	Ø 3/8"	Ø 1/2"

Note 1) Indicate the sizes on the manifold specification sheet.

Note 2) To avoid interference with the body or piping, select downward elbow port when mounting the optional spacer assembly. For details, refer to the **WEB catalogue** or the SY series catalogue (CAT. EUS11-103).

Note 3) The direction of P, E port fittings is the same as for A, B port. If selecting "LM", indicate it on the manifold specification sheet for the P, E port fitting direction.

**8 Mounting and Option**

	Mounting	Option	
		Name plate	Station number
—	Direct mounting	—	—
<b>AA</b>		●	●
<b>BA</b>		●	—
<b>D</b> (Note 1)	DIN rail mounting	—	—
<b>A</b> (Note 1)		●	●
<b>B</b> (Note 1)		●	—

Note 1) Refer to "DIN Rail Option" below.

\* Select the direct mounting type for Type 11 (Bottom ported).

**DIN Rail Option**

—	With DIN bracket, DIN rail with standard length
<b>0</b>	With DIN bracket, without DIN rail
<b>3</b> (Note)	With DIN bracket, DIN rail for 3 stations
⋮	⋮
<b>16</b> (Note)	With DIN bracket, DIN rail for 16 stations

Note) Specify a longer rail than the length of valve stations.

\* If the DIN rail must be mounted without an SI Unit, select "D0" and order the DIN rail separately. Refer to L 3 of the dimensions for the DIN rail length. For the DIN rail part number, refer to the **WEB catalogue** or the SY series catalogue (CAT. EUS11-103).

\* For the fixation of DIN rail mounting type manifold, refer to the **WEB catalogue** or the SY series catalogue (CAT. EUS11-103).



# Series SY3000/5000/7000

## How to Order Valves (With mounting screw)

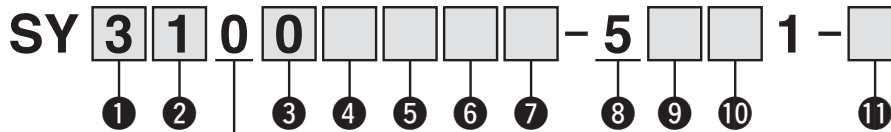

• Side/Bottom ported

### 1 Series

3	SY3000
5	SY5000
7	SY7000

### 2 Type of actuation

1	2-position	Single
2		Double
3	3-position	Closed centre
4		Exhaust centre
5		Pressure centre
A (Note)	4-position dual	N.C./N.C.
B (Note)		N.O./N.O.
C (Note)	3-port valve	N.C./N.O.

Note) Select the rubber seal type for the 4-position dual 3-port valve.

### 3 Seal type

0	Rubber seal
1	Metal seal

### 4 Pilot type

—	Internal pilot
R	External pilot

### 5 Back pressure check valve

—	None
H (Note)	Built-in

Note) Select the rubber seal type when the back pressure check valve is built-in. Manifold installed type is available if the back pressure check valve is required for a valve with metal seal. For ordering example, refer to the **WEB catalogue** or the SY series catalogue (CAT. EUS11-103). However, it is not recommended to use the built-in valve type and the manifold installed type at the same time because it will reduce the flow.

\* Select “—” for 3-position type and the SY7000.

### 6 Pilot valve option

—	Standard (0.7 MPa)
B	Quick response type (0.7 MPa)
K (Note)	High pressure type (1.0 MPa)

Note) Select the metal seal type for high pressure type.

### 7 Coil type

—	Standard
T	With power saving circuit (Continuous duty type) (Note 1) 2)

Note 1) Be sure to select the power saving circuit type when the valve is continuously energised for long periods of time.

Note 2) Be careful of the energising time when the power saving circuit is selected. For details, refer to the **WEB catalogue** or the SY series catalogue (CAT. EUS11-103).

### 8 Rated voltage

5	24 V DC
---	---------

### 9 Light/surge voltage suppressor and common specification

	With light	Surge voltage suppressor	Common specification
R	—	●	Non-polar
U	●		
S	—		Positive common
Z	●		
NS	—		
NZ	●		

\* Only “Z” and “NZ” types are available for with the power saving circuit. Select a valve from “R, U, S or Z” when the SI Unit specification is “A2” (positive common). Select a valve from “R,U, NS or NZ” when the SI Unit specification is “A2N” (negative common).

### 10 Manual override

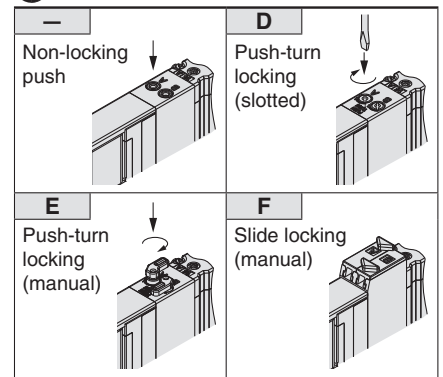

### 11 Type of mounting screw

—	Round head combination screw
B	Hexagon socket head cap screw
K	Round head combination screw (Falling-out-prevention type) (Note)
H	Hexagon socket head cap screw (Falling-out-prevention type) (Note)

Note) For “K” and “H”, the valve body cover has a drop prevention construction to stop the mounting screws from falling out when the valve is removed for maintenance etc.

\* **When ordering a valve individually, the base gasket is not included.**

Since the base gasket is attached to the manifold, please order the base gasket separately if it is needed for maintenance service.

For details, refer to the **WEB catalogue** or the SY series catalogue (CAT. EUS11-103).

\* Select “—” or “K” for the optional individual SUP/EXH spacer assembly, interface regulator or double check spacer assembly with residual pressure release valve.

# Gateway Decentralised System

## 5 Port Solenoid Valve

### Series SY3000/5000/7000



RoHS

Type 12  
Top Ported

For detailed specifications, Common Precautions and Specific Product Precautions, refer to the **WEB catalogue** or the SY series catalogue (CAT. EUS11-103).

### How to Order Manifold

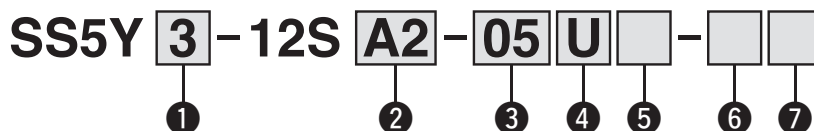

#### 1 Series

3	SY3000
5	SY5000
7	SY7000

\* For mixed mounting, refer to the **WEB catalogue** or the SY series catalogue (CAT. EUS11-103).

#### 2 SI Unit (Number of outputs, Output polarity, Max. number of valve stations)

A2	16 outputs, Positive common <sup>Note 1)</sup> , 1 to 8 stations (16 stations) <sup>Note 2)</sup>
A2N	16 outputs, Negative common <sup>Note 1)</sup> , 1 to 8 stations (16 stations) <sup>Note 2)</sup>

Note 1) Ensure a match with the common specification of the valve to be used.

Note 2) ( ): Maximum number of stations for single wiring.

#### 3 Valve stations

Stations	Note
02	2 stations Double wiring <sup>Note 1)</sup>
⋮	
08	
02	2 stations Specified layout <sup>Note 2)</sup> (Available up to 16 solenoids)
⋮	
16	

Note 1) Double wiring: 2-position single, double, 3-position and 4-position valves can be used on all manifold stations. Use of a 2-position single solenoid will result in an unused control signal. If this is not desired, order with a specified layout.

Note 2) Specified layout: Indicate the wiring specifications on the manifold specification sheet. (Note that 2-position double, 3-position and 4-position valves cannot be used where single wiring has been specified.)

Note 3) For the product without the SI Unit (S0), note the maximum number of solenoids of the SI Unit that will be mounted. If the layout is specified, indicate it on the manifold specification sheet.

\* This also includes the number of blanking plate assembly.

#### 4 P, E port entry

U <sup>Note)</sup>	U side (2 to 10 stations)
D <sup>Note)</sup>	D side (2 to 10 stations)
B	Both sides (2 to 16 stations)

Note) For type "S", supply/exhaust block assembly with built-in silencer, choose "U" or "D" for P, E port entry.

#### 5 SUP/EXH block assembly

—	Internal pilot
S <sup>Note 1)</sup>	Internal pilot, Built-in silencer <sup>Note 2)</sup>
R	External pilot

Note 1) For type "S", supply/exhaust block assembly with built-in silencer, choose "U" or "D" for P, E port entry. 3/5(E) port is plugged. The silencer exhaust port is located on the opposite side of P, E port entry. (Example: When the P, E port entry is D side, the silencer exhaust port is U side.)

Note 2) When the built-in silencer type is used, keep the exhaust port from coming in direct contact with water or other liquids.

### How to Order Manifold Assembly

#### Example

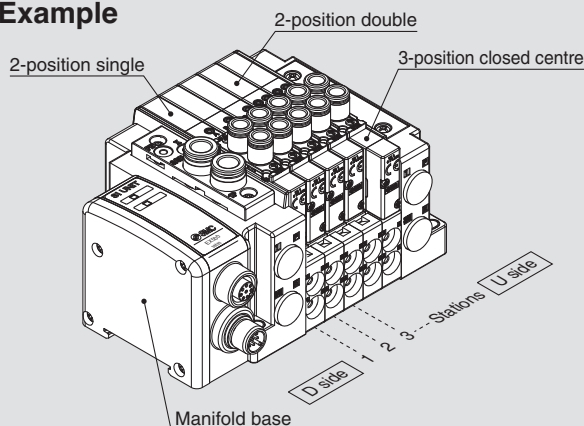

SS5Y3-12SA2-05D.....1 set (Manifold base part number)  
 \* SY3130-5U1-C6.....3 sets (2-position single part number)  
 \* SY3230-5U1-C6.....1 set (2-position double part number)  
 \* SY3330-5U1-C6.....1 set (3-position closed centre part number)

The asterisk denotes the symbol for assembly. Prefix it to the part numbers of the valve etc.

- The valve arrangement is numbered as the 1st station from the D side.
- Under the manifold base part number, state the valves to be mounted in order from the 1st station as shown in the figure above. If the arrangement becomes complicated, specify on the manifold specification sheet.

#### 6 P, E port size (One-touch fittings)

	SY3000	SY5000	SY7000
—	Ø 8	Ø 10	Ø 12
N <sup>Note)</sup>	Ø 5/16"	Ø 3/8"	Ø 1/2"

Note) For "N", sizes are in inches.

#### 7 Mounting

—	Direct mounting
D	With DIN bracket, DIN rail with standard length
D0	With DIN bracket, without DIN rail
D3 <sup>Note)</sup>	With DIN bracket, DIN rail for 3 stations
⋮	⋮
D16 <sup>Note)</sup>	With DIN bracket, DIN rail for 16 stations

Note) Specify a longer rail than the length of valve stations.

\* If the DIN rail must be mounted without an SI Unit, select "D0". Then, refer to L3 of the dimensions for the DIN rail length and order separately. For the DIN rail part number, refer to the **WEB catalogue** or the SY series catalogue (CAT. EUS11-103).

\* For the fixation of DIN rail mounting type manifold, refer to the **WEB catalogue** or the SY series catalogue (CAT. EUS11-103).

## How to Order Valves (With mounting screw)

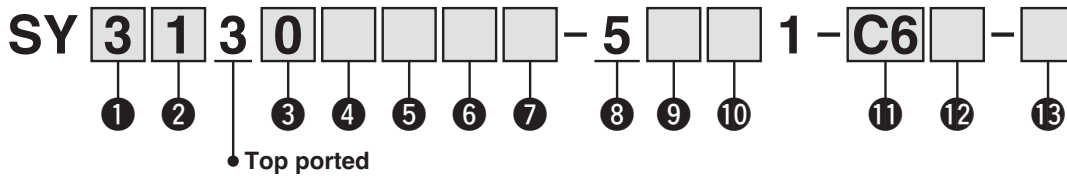

### 1 Series

3	SY3000
5	SY5000
7	SY7000

### 2 Type of actuation

1	2-position	Single
2		Double
3	3-position	Closed centre
4		Exhaust centre
5		Pressure centre
A (Note)	4-position dual	N.C./N.C.
B (Note)		N.O./N.O.
C (Note)	3-port valve	N.C./N.O.

Note) Select the rubber seal type for the 4-position dual 3-port valve.

### 3 Seal type

0	Rubber seal
1	Metal seal

### 4 Pilot type

—	Internal pilot
R	External pilot

### 5 Back pressure check valve (Built-in valve type)

—	None
H (Note)	Built-in

Note) Select the rubber seal type when the back pressure check valve is built-in. Manifold installed type is available if the back pressure check valve is required for a valve with metal seal. For ordering example, refer to the SY series catalogue (CAT. EUS11-103). However, it is not recommended to use the built-in valve type and the manifold installed type at the same time because it will reduce the flow.

\* Select “—” for 3-position type and the SY7000.

### 6 Pilot valve option

—	Standard (0.7 MPa)
B	Quick response type (0.7 MPa)
K (Note)	High pressure type (1.0 MPa)

Note) Select the metal seal type for high pressure type.

### 7 Coil type

—	Standard
T	With power saving circuit (Continuous duty type) (Note 1) 2)

Note 1) Be sure to select the power saving circuit type when the valve is continuously energised for long periods of time.

Note 2) Be careful of the energising time when the power saving circuit is selected. For details, refer to the SY series catalogue (CAT. EUS11-103).

### 8 Rated voltage

5	24 V DC
---	---------

### 9 Light/surge voltage suppressor and common specification

	With light	Surge voltage suppressor	Common specification
R	—	●	Non-polar
U	●		
S	—		Positive common
Z	●		
NS	—	Negative common	
NZ	●		

\* Only “Z” and “NZ” types are available for with the power saving circuit. Select a valve from “R, U, S or Z” when the SI Unit specification is “A2” (positive common). Select a valve from “R, U, NS or NZ” when the SI Unit specification is “A2N” (negative common).

### 10 Manual override

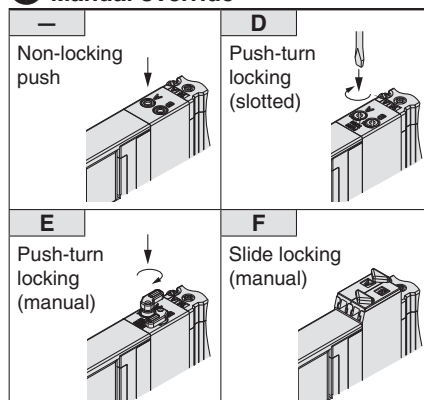

### 11 A, B port size

Thread piping	Port size	SY3000	SY5000	SY7000
		M5	M5 x 0.8	●
01	1/8	—	●	—
02	1/4	—	—	●

### One-touch fitting (Metric)

A, B port	SY3000	SY5000	SY7000
	C2	∅ 2	●
C3	∅ 3.2	●	—
C4	∅ 4	●	●
C6	∅ 6	●	●
C8	∅ 8	—	●
C10	∅ 10	—	●
C12	∅ 12	—	●

### One-touch fitting (Inch)

A, B port	SY3000	SY5000	SY7000
	N1	∅ 1/8"	●
N3	∅ 5/32"	●	●
N7	∅ 1/4"	●	●
N9	∅ 5/16"	—	●
N11	∅ 3/8"	—	●

### 12 A, B port thread type

—	Rc
F	G
N	NPT
T	NPTF

\* Select “—” for M5.

### 13 Type of mounting screw

—	Round head combination screw
B	Hexagon socket head cap screw
K	Round head combination screw (Falling-out-prevention type) (Note)
H	Hexagon socket head cap screw (Falling-out-prevention type) (Note)

Note) For “K” and “H”, the valve body cover has a drop prevention construction to stop the mounting screws from falling out when the valve is removed for maintenance etc.

\* When ordering a valve individually, the base gasket is not included.

Since the base gasket is attached to the manifold, please order the base gasket separately if it is needed for maintenance service. For details, refer to the SY series catalogue (CAT. EUS11-103).

\* Select “—” or “K” for the optional individual SUP/EXH spacer assembly or interface regulator.

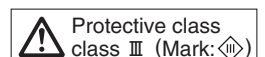

## Dimensions

Type 10/Side Ported

Series SY3000

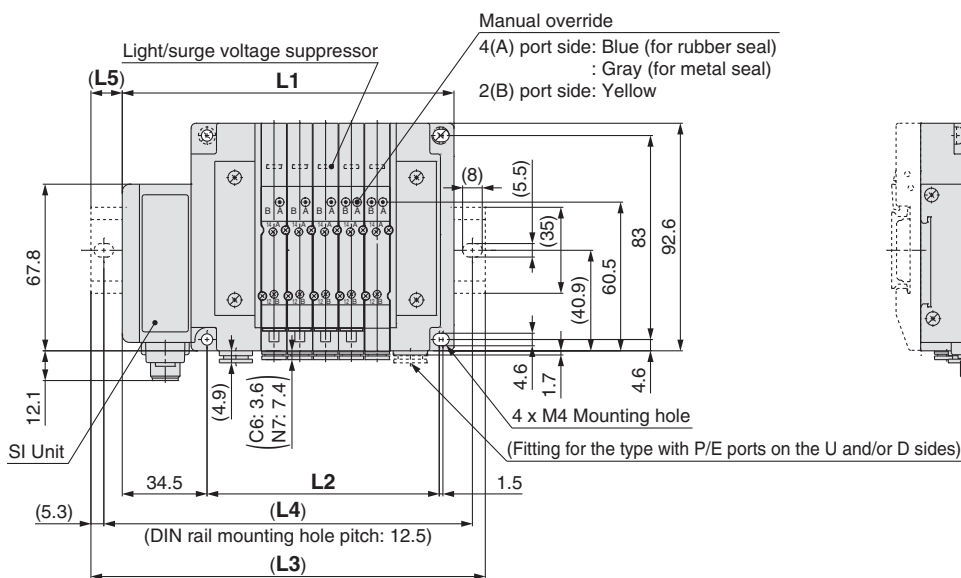
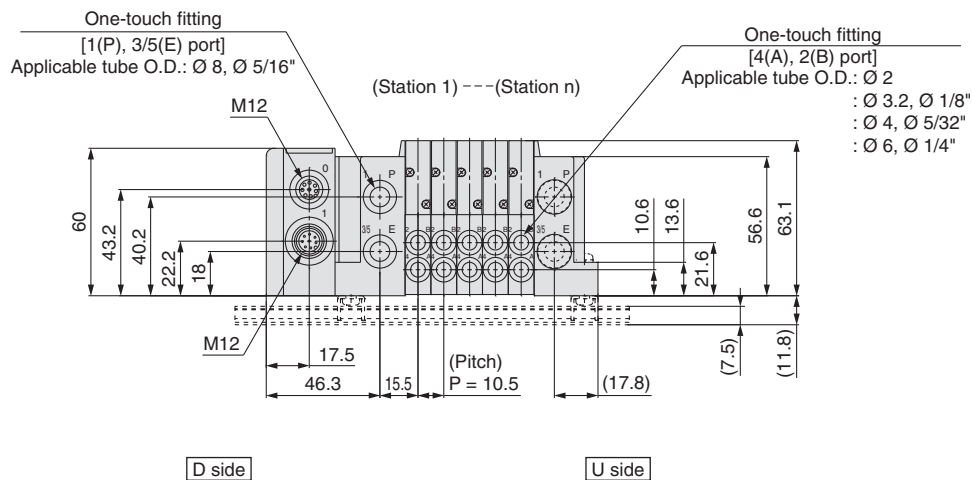

Note) These figures show the "SS5Y3-10SA2-05D-C6".

n: Stations	2	3	4	5	6	7	8	9	10	11	12	13	14	15	16
L1	103.5	114	124.5	135	145.5	156	166.5	177	187.5	198	208.5	219	229.5	240	250.5
L2	63	73.5	84	94.5	105	115.5	126	136.5	147	157.5	168	178.5	189	199.5	210
L3	135.5	148	148	160.5	173	185.5	198	210.5	223	223	235.5	248	260.5	273	285.5
L4	125	137.5	137.5	150	162.5	175	187.5	200	212.5	212.5	225	237.5	250	262.5	275
L5	16	17	12	13	14	15	16	17	18	12.5	13.5	14.5	15.5	16.5	17.5

For dimensions of Type 11/Bottom ported type and Type 12/Top ported type, refer to the **WEB catalogue** or the SY series catalogue (CAT. EUS11-103).

# Series SY5000

## Dimensions

Type 10/Side Ported Series SY5000

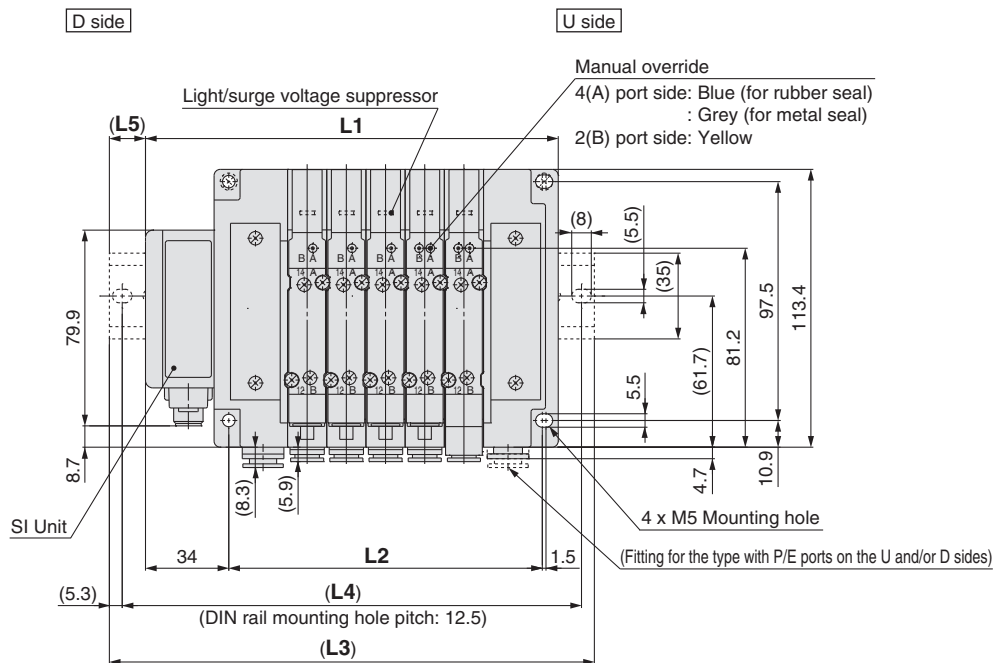
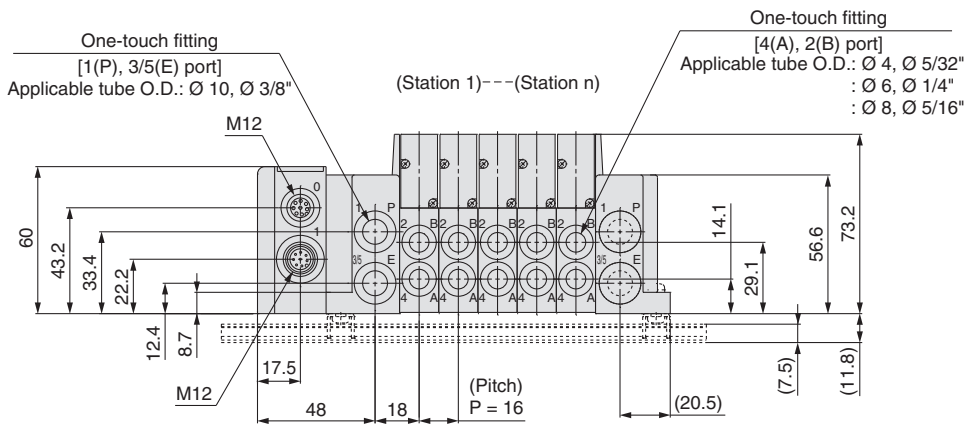

Note) These figures show the "SS5Y5-10SA2-05D-C8".

n: Stations	2	3	4	5	6	7	8	9	10	11	12	13	14	15	16
L1	120.5	136.5	152.5	168.5	184.5	200.5	216.5	232.5	248.5	264.5	280.5	296.5	312.5	328.5	344.5
L2	80	96	112	128	144	160	176	192	208	224	240	256	272	288	304
L3	148	160.5	185.5	198	210.5	235.5	248	260.5	273	298	310.5	323	348	360.5	373
L4	137.5	150	175	187.5	200	225	237.5	250	262.5	287.5	300	312.5	337.5	350	362.5
L5	14	12	16.5	15	13	17.5	16	14	12.5	17	15	13.5	18	16	14.5

For dimensions of Type 11/Bottom ported type and Type 12/Top ported type, refer to the **WEB catalogue** or the SY series catalogue (CAT. EUS11-103).

## Dimensions

Type 10/Side Ported Series SY7000

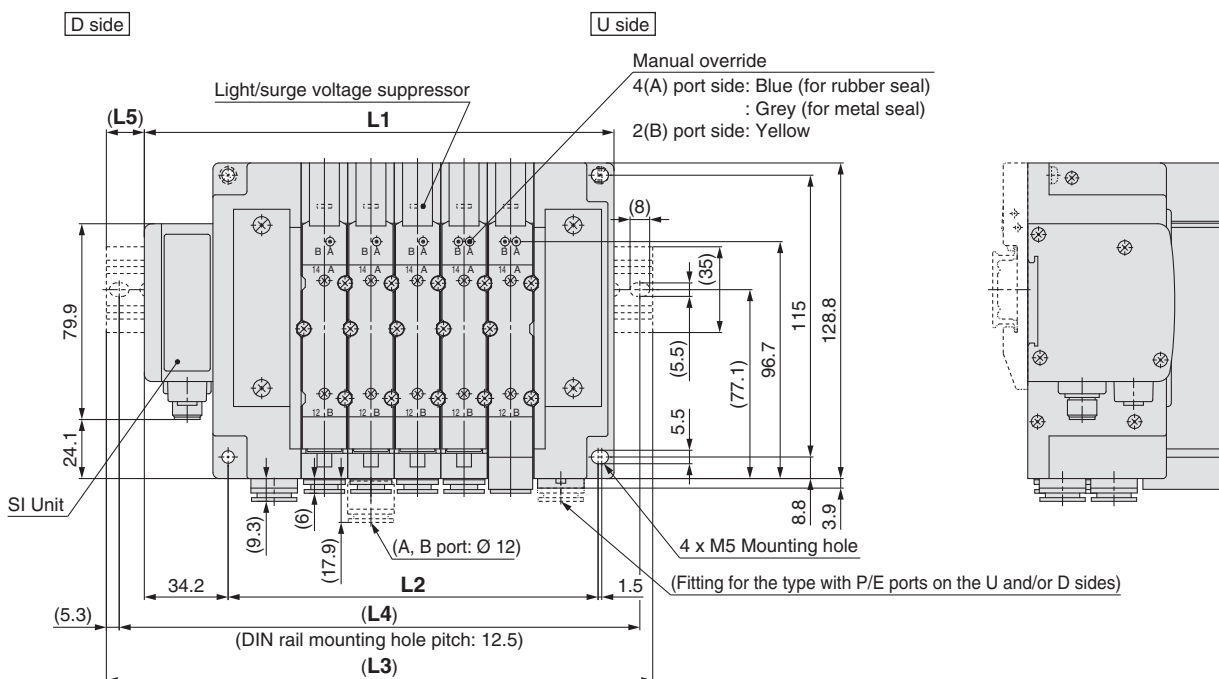
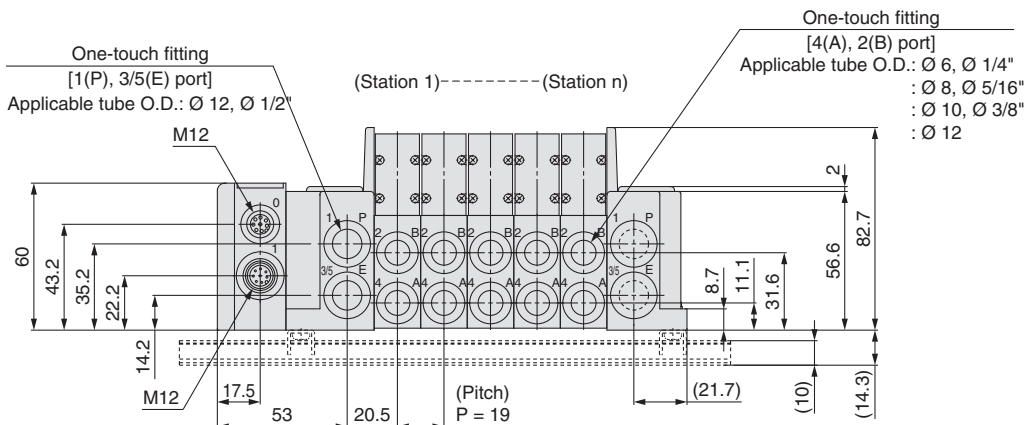

Note) These figures show the "SS5Y7-10SA2-05D-C10".

n: Stations	2	3	4	5	6	7	8	9	10	11	12	13	14	15	16
<b>L1</b>	134.7	153.7	172.7	191.7	210.7	229.7	248.7	267.7	286.7	305.7	324.7	343.7	362.7	381.7	400.7
<b>L2</b>	94	113	132	151	170	189	208	227	246	265	284	303	322	341	360
<b>L3</b>	160.5	185.5	198	223	235.5	260.5	273	298	310.5	335.5	348	373	398	410.5	435.5
<b>L4</b>	150	175	187.5	212.5	225	250	262.5	287.5	300	325	337.5	362.5	387.5	400	425
<b>L5</b>	13	16	12.5	15.5	12.5	15.5	12	15	12	15	11.5	14.5	17.5	14.5	17.5

For dimensions of Type 11/Bottom ported type and Type 12/Top ported type, refer to the **WEB catalogue** or the SY series catalogue (CAT. EUS11-103).

Gateway Decentralised System  
SY  
VQC  
S0700  
SV

# Gateway Decentralised System

## 5 Port Solenoid Valve

### Series VQC1000



For detailed specifications, Common Precautions and Specific Product Precautions, refer to the **WEB catalogue** or the VQC1000/2000 series catalogue (CAT. EUS11-101).

### How to Order Manifold

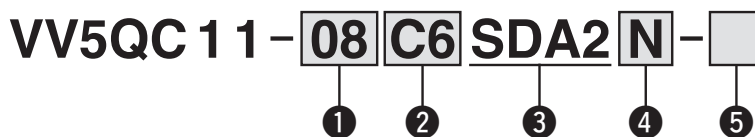

#### 1 Valve stations

	Stations	Note
<b>01</b>	1 station	Double wiring
⋮	⋮	
<b>08</b>	8 stations	
<b>01</b>	1 station	Mixed wiring, Specified layout <sup>Note)</sup> (Available up to 16 solenoids)
⋮	⋮	
<b>16</b>	16 stations	

Note) Specified layout: Indicate the wiring specifications on the manifold specification sheet. (Note that 2-position double, 3-position and 4-position valves cannot be used where single wiring has been specified.) In addition, select the option "K".

#### 2 A, B port size

##### Metric size

<b>C3</b>	Straight piping: Ø 3.2 One-touch fitting
<b>C4</b>	Straight piping: Ø 4 One-touch fitting
<b>C6</b>	Straight piping: Ø 6 One-touch fitting
<b>M5</b>	Straight piping: M5 thread
<b>CM</b> <sup>Note 1)</sup>	Straight piping: Mixed sizes and with port plug
<b>L3</b>	Top ported elbow: Ø 3.2 One-touch fitting
<b>L4</b>	Top ported elbow: Ø 4 One-touch fitting
<b>L6</b>	Top ported elbow: Ø 6 One-touch fitting
<b>L5</b>	Top ported elbow: M5 thread
<b>B3</b>	Bottom ported elbow: Ø 3.2 One-touch fitting
<b>B4</b>	Bottom ported elbow: Ø 4 One-touch fitting
<b>B6</b>	Bottom ported elbow: Ø 6 One-touch fitting
<b>B5</b>	Bottom ported elbow: M5 thread
<b>LM</b> <sup>Note 1)</sup>	Elbow piping: Mixed sizes and with port plug
<b>MM</b> <sup>Note 2)</sup>	Mixed size for different types of piping, option installed

##### Inch size

<b>N1</b>	Straight piping: Ø 1/8" One-touch fitting
<b>N3</b>	Straight piping: Ø 5/32" One-touch fitting
<b>N7</b>	Straight piping: Ø 1/4" One-touch fitting
<b>NM</b> <sup>Note 1)</sup>	Straight piping: Mixed sizes and with port plug
<b>LN1</b>	Top ported elbow: Ø 1/8" One-touch fitting
<b>LN3</b>	Top ported elbow: Ø 5/32" One-touch fitting
<b>LN7</b>	Top ported elbow: Ø 1/4" One-touch fitting
<b>BN1</b>	Bottom ported elbow: Ø 1/8" One-touch fitting
<b>BN3</b>	Bottom ported elbow: Ø 5/32" One-touch fitting
<b>BN7</b>	Bottom ported elbow: Ø 1/4" One-touch fitting
<b>LNM</b> <sup>Note 1)</sup>	Elbow piping: Mixed sizes and with port plug
<b>BNM</b> <sup>Note 2)</sup>	Mixed size for different types of piping, option installed

Note 1) Indicate the sizes on the manifold specification sheet.

Note 2) When a combination of straight and elbow piping is or when option such as dual flow fitting assembly is mounted, please mention the mounting conditions in the Manifold Specification.

#### 3 SI Unit (Number of outputs, Max. number of valve stations)

<b>SD0</b>	Without SI Unit
<b>SDA2</b>	16 outputs, 1 to 8 stations (16 stations <sup>Note)</sup> )

Note) ( ) : Maximum number of stations for mixed single and double wiring.

#### 4 SI Unit (Output polarity)

—	Positive common
<b>N</b>	Negative common

\* Ensure a match with the common specification of the valve to be used.

\* Select "—" for without SI Unit.

#### 5 Option

—	None
<b>B</b> <sup>Note 1)</sup>	With back pressure check valve (All stations)
<b>D</b>	With DIN bracket, DIN rail with standard length
<b>D0</b>	With DIN bracket, without DIN rail
<b>D</b> <input type="checkbox"/> <sup>Note 2)</sup>	With DIN bracket, DIN rail for <input type="checkbox"/> stations
<b>K</b> <sup>Note 3)</sup>	Special wiring specification (Except double wiring)
<b>N</b>	With name plate
<b>R</b> <sup>Note 4)</sup>	External pilot
<b>S</b> <sup>Note 5)</sup>	Built-in silencer, Direct exhaust

\* When multiple symbols are specified, indicate them alphabetically. Example) -BRS

Note 1) When a back pressure check valve is used only for specified station, specify the back pressure check valve part number, and specify the station number to which the valve is mounted, on the manifold specification sheet.

Note 2) : Specify a longer rail than the length of valve stations.  
Example) "-D08"

In this case, the valves will be mounted on the DIN rail for 8 stations, regardless of the number of manifold stations.

Note 3) When single wiring and double wiring are mixed, specify wiring type of each station on the manifold specification sheet.

Note 4) For external pilot option "-R", indicate the external pilot specification "R" for the applicable valves as well.

Note 5) Built-in silencer type does not satisfy IP67.



**How to Order Valves**

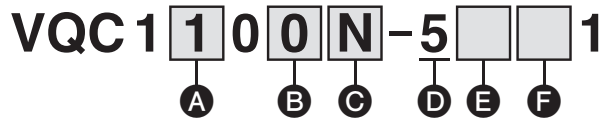

**A Type of actuation**

1	2-position single	<b>A</b> Note)	4-position dual 3-port valve (N.C./N.C.)
2	2-position double	<b>B</b> Note)	4-position dual 3-port valve (N.O./N.O.)
3	3-position closed centre	<b>C</b> Note)	4-position dual 3-port valve (N.C./N.O.)
4	3-position exhaust centre		
5	3-position pressure centre		

Note) Only rubber seal type

**B Seal type**

0	Metal seal
1	Rubber seal

**C Function**

—	Standard (0.4 W)
<b>B</b>	Quick response type (0.95 W)
<b>K</b> Note 2)	High pressure type (1.0 MPa, 0.95 W)
<b>N</b> Note 3)	Negative common
<b>R</b> Note 4)	External pilot

Note 1) When multiple symbols are specified, indicate them alphabetically. However, combination of "B" and "K" is not possible.

Note 2) Metal seal type only

Note 3) When the negative common is specified for the SI Unit, select and mount the valve of negative common.

Note 4) Dual 3-port is not applicable.

**D Coil voltage**

5	24 V DC
---	---------

**E Light/surge voltage suppressor**

—	With light/surge voltage suppressor
---	-------------------------------------

**F Manual override**

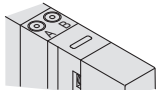
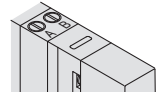
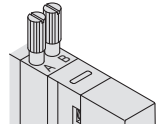
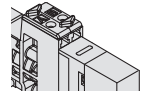
—	Non-locking push (tool required)	
<b>B</b>	Push-turn locking (tool required)	
<b>C</b>	Turn locking (manual)	
<b>D</b>	Slide locking (manual)	

**How to Order Manifold Assembly**

**Example**

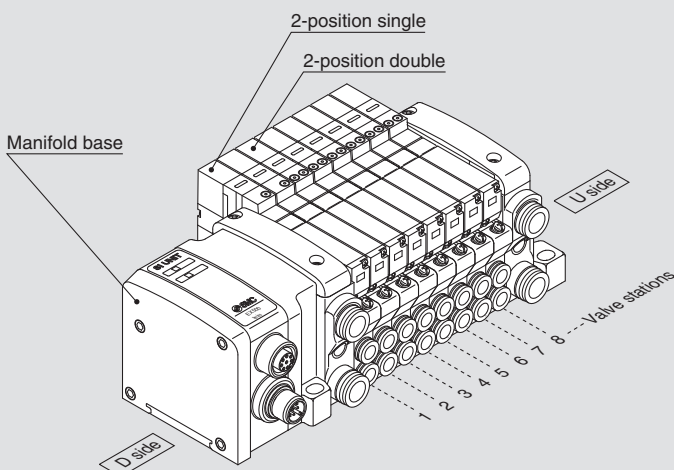

VV5QC11-08C6SDA2N...1 set (Manifold base part number)  
 \* VQC1100N-51.....2 sets (2-position single part number)  
 \* VQC1200N-51.....6 sets (2-position double part number)

The asterisk denotes the symbol for assembly. Prefix it to the part numbers of the valve etc.

- The valve arrangement is numbered as the 1st station from the D side.
- Under the manifold base part number, state the valves to be mounted in order from the 1st station as shown in the figure above. If the arrangement becomes complicated, specify on the manifold specification sheet.

# Series VQC1000

## Dimensions

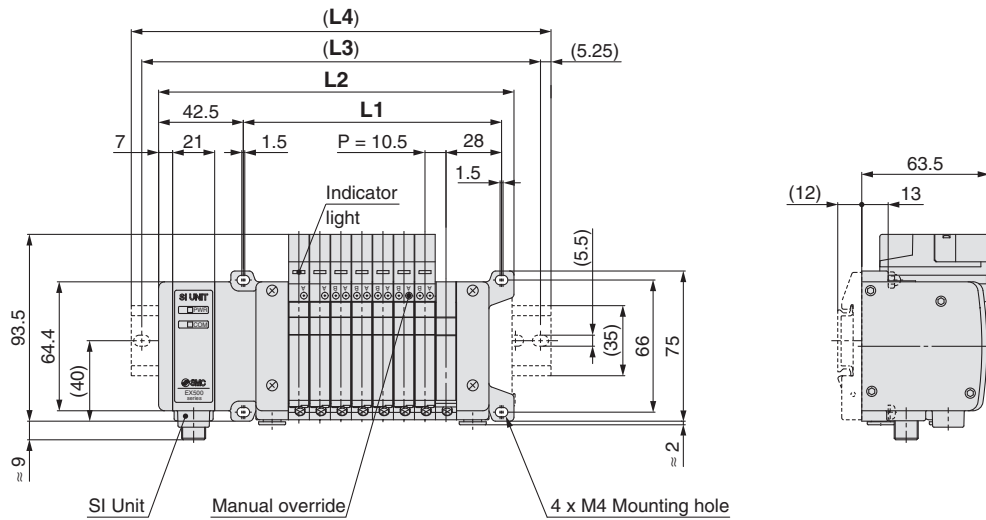
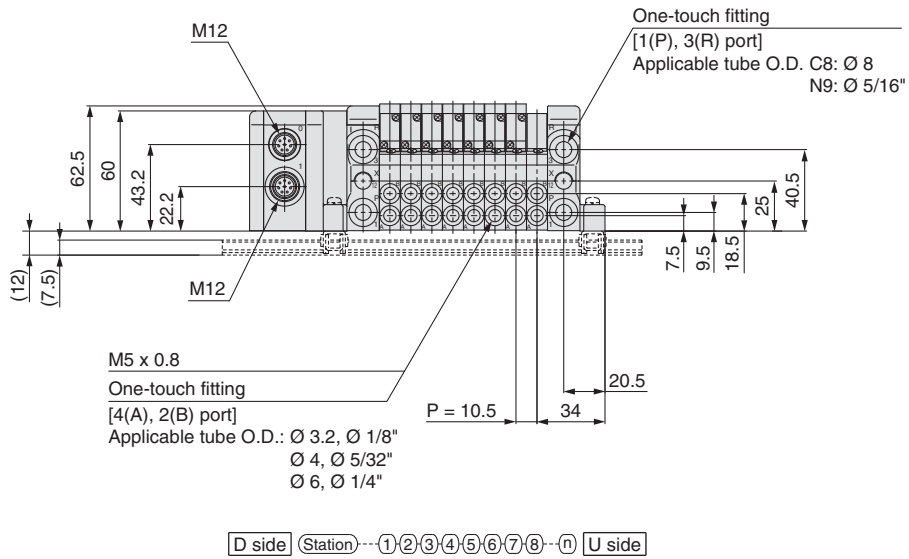

Formula:  $L1 = 10.5n + 45$ ,  $L2 = 10.5n + 93.5$  n: Stations (Maximum 16 stations)

L \ n	1	2	3	4	5	6	7	8	9	10	11	12	13	14	15	16
L1	55.5	66	76.5	87	97.5	108	118.5	129	139.5	150	160.5	171	181.5	192	202.5	213
L2	104	114.5	125	135.5	146	156.5	167	177.5	188	198.5	209	219.5	230	240.5	251	261.5
L3	125	137.5	150	162.5	175	187.5	187.5	200	212.5	225	237.5	250	250	262.5	275	287.5
L4	135.5	148	160.5	173	185.5	198	198	210.5	223	235.5	248	260.5	260.5	273	285.5	298

# Gateway Decentralised System

## 5 Port Solenoid Valve

### Series VQC2000



For detailed specifications, Common Precautions and Specific Product Precautions, refer to the **WEB catalogue** or the VQC1000/2000 series catalogue (CAT. EUS11-101).

### How to Order Manifold

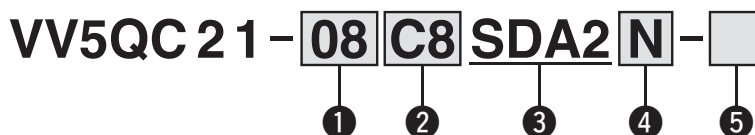

#### 1 Valve stations

Stations	Note
01	1 station
⋮	
08	8 stations
01	1 station
⋮	
16	16 stations

Double wiring

Mixed wiring, Specified layout <sup>Note)</sup>  
(Available up to 16 solenoids)

Note) Specified layout: Indicate the wiring specifications on the manifold specification sheet. (Note that 2-position double, 3-position and 4-position valves cannot be used where single wiring has been specified.) In addition, select the option "K".

#### 3 SI Unit (Number of outputs, Max. number of valve stations)

SD0	Without SI Unit
SDA2	16 outputs, 1 to 8 stations (16 stations <sup>Note)</sup> )

Note) ( ) : Maximum number of stations for mixed single and double wiring.

#### 2 A, B port size

##### Metric size

C4	Straight piping: Ø 4 One-touch fitting
C6	Straight piping: Ø 6 One-touch fitting
C8	Straight piping: Ø 8 One-touch fitting
CM <sup>Note 1)</sup>	Straight piping: Mixed sizes and with port plug
L4	Top ported elbow: Ø 4 One-touch fitting
L6	Top ported elbow: Ø 6 One-touch fitting
L8	Top ported elbow: Ø 8 One-touch fitting
B4	Bottom ported elbow: Ø 4 One-touch fitting
B6	Bottom ported elbow: Ø 6 One-touch fitting
B8	Bottom ported elbow: Ø 8 One-touch fitting
LM <sup>Note 1)</sup>	Elbow piping: Mixed sizes and with port plug
MM <sup>Note 2)</sup>	Mixed size for different types of piping, option installed

##### Inch size

N1	Straight piping: Ø 1/8" One-touch fitting
N3	Straight piping: Ø 5/32" One-touch fitting
N7	Straight piping: Ø 1/4" One-touch fitting
NM <sup>Note 1)</sup>	Straight piping: Mixed sizes and with port plug
LN1	Top ported elbow: Ø 1/8" One-touch fitting
LN3	Top ported elbow: Ø 5/32" One-touch fitting
LN7	Top ported elbow: Ø 1/4" One-touch fitting
BN1	Bottom ported elbow: Ø 1/8" One-touch fitting
BN3	Bottom ported elbow: Ø 5/32" One-touch fitting
BN7	Bottom ported elbow: Ø 1/4" One-touch fitting
LNM <sup>Note 1)</sup>	Elbow piping: Mixed sizes and with port plug
BNM <sup>Note 2)</sup>	Mixed size for different types of piping, option installed

Note 1) Indicate the sizes on the manifold specification sheet.

Note 2) When a combination of straight and elbow piping is or when option such as dual flow fitting assembly is mounted, please mention the mounting conditions in the Manifold Specification.

#### 4 SI Unit (Output polarity)

—	Positive common
N	Negative common

\* Ensure a match with the common specification of the valve to be used.

\* Select "—" for without SI Unit.

#### 5 Option

—	None
B <sup>Note 1)</sup>	With back pressure check valve (All stations)
D	With DIN bracket, DIN rail with standard length
D0	With DIN bracket, without DIN rail
D□ <sup>Note 2)</sup>	With DIN bracket, DIN rail for □ stations
K <sup>Note 3)</sup>	Special wiring specification (Except double wiring)
N	With name plate
R <sup>Note 4)</sup>	External pilot
S <sup>Note 5)</sup>	Built-in silencer, Direct exhaust
T <sup>Note 6)</sup>	P and R ports included on both sides of the U side

\* When multiple symbols are specified, indicate them alphabetically. Example) -BRS

Note 1) When a back pressure check valve is used only for specified station, specify the back pressure check valve part number, and specify the station number to which the valve is mounted, on the manifold specification sheet.

Note 2) □: Specify a longer rail than the length of valve stations.

Example) "D08"

In this case, the valves will be mounted on the DIN rail for 8 stations, regardless of the number of manifold stations.

Note 3) When single wiring and double wiring are mixed, specify wiring type of each station on the manifold specification sheet.

Note 4) For external pilot option "-R", indicate the external pilot specification "R" for the applicable valves as well.

Note 5) Built-in silencer type does not satisfy IP67.

Note 6) P and R ports are included on both sides of U side (cylinder port and coil side) with Ø 12 One-touch fittings.

## How to Order Valves

VQC 2 **1** **0** **0** **N** - **5** **□** **□** **1**

A
B
C
D
E
F

### A Type of actuation

<b>1</b>	2-position single	<b>A</b> Note)	4-position dual 3-port valve (N.C./N.C.)
<b>2</b>	2-position double	<b>B</b> Note)	4-position dual 3-port valve (N.O./N.O.)
<b>3</b>	3-position closed centre	<b>C</b> Note)	4-position dual 3-port valve (N.C./N.O.)
<b>4</b>	3-position exhaust centre		
<b>5</b>	3-position pressure centre		

Note) Only rubber seal type

### B Seal type

<b>0</b>	Metal seal
<b>1</b>	Rubber seal

### C Function

—	Standard (0.4 W)
<b>B</b>	Quick response type (0.95 W)
<b>K</b> Note 2)	High pressure type (1.0 MPa, 0.95 W)
<b>N</b> Note 3)	Negative common
<b>R</b> Note 4)	External pilot

Note 1) When multiple symbols are specified, indicate them alphabetically. However, combination of "B" and "K" is not possible.

Note 2) Metal seal type only

Note 3) When the negative common is specified for the SI Unit, select and mount the valve of negative common.

Note 4) Dual 3-port is not applicable.

### D Coil voltage

<b>5</b>	24 V DC
----------	---------

### E Light/surge voltage suppressor

—	With light/surge voltage suppressor
---	-------------------------------------

### F Manual override

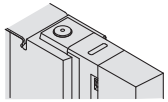
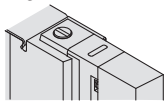
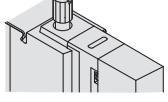
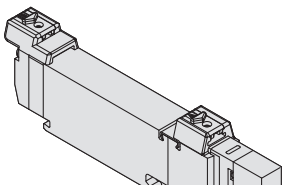
—	Non-locking push (tool required)	
<b>B</b>	Push-turn locking (tool required)	
<b>C</b>	Turn locking (manual)	
<b>D</b>	Slide locking (manual)	

## How to Order Manifold Assembly

### Example

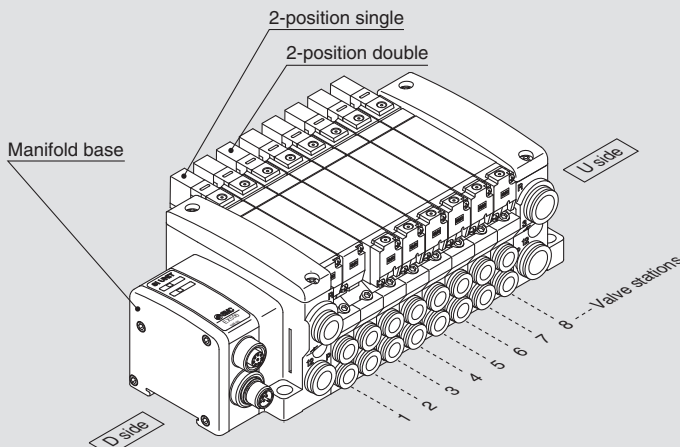

VV5QC21-08C6SDA2N.....1 set (Manifold base part number)  
 \* VQC2100-51.....2 sets (2-position single part number)  
 \* VQC2200-51.....6 sets (2-position double part number)

↳ The asterisk denotes the symbol for assembly.  
 Prefix it to the part numbers of the valve etc.

- The valve arrangement is numbered as the 1st station from the D side.
- Under the manifold base part number, state the valves to be mounted in order from the 1st station as shown in the figure above. If the arrangement becomes complicated, specify on the manifold specification sheet.

Dimensions

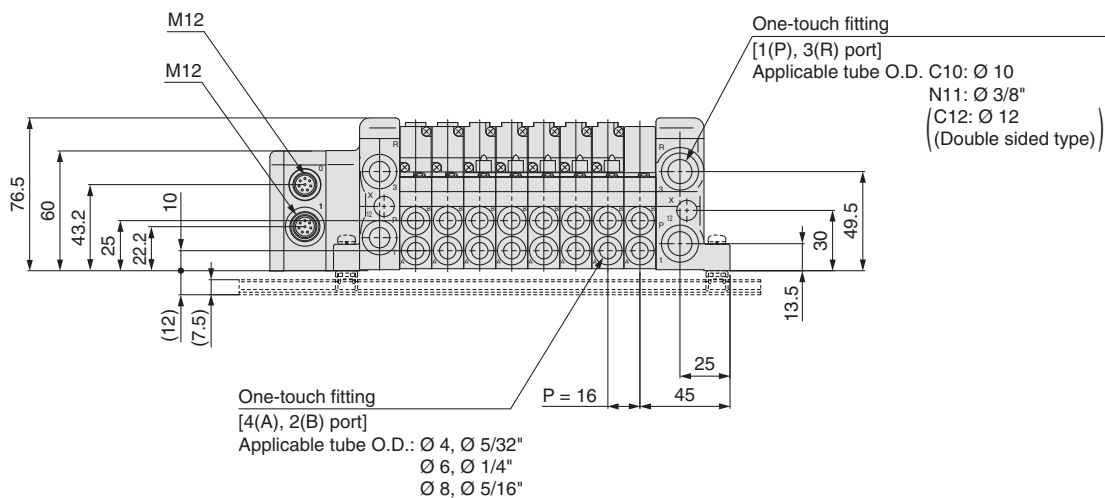

D side Station 1 2 3 4 5 6 7 8 n U side

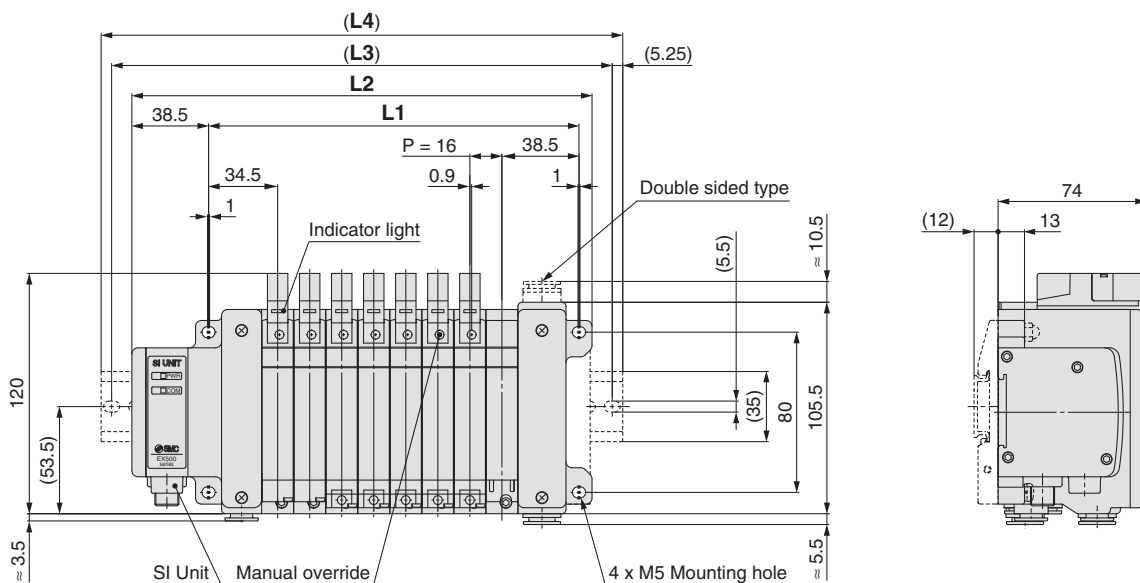

Formula:  $L1 = 16n + 57$ ,  $L2 = 16n + 102$  n: Stations (Maximum 16 stations)

L \ n	1	2	3	4	5	6	7	8	9	10	11	12	13	14	15	16
L1	73	89	105	121	137	153	169	185	201	217	233	249	265	281	297	313
L2	118	134	150	166	182	198	214	230	246	262	278	294	310	326	342	358
L3	137.5	162.5	175	187.5	212.5	225	237.5	250	275	287.5	300	325	337.5	350	362.5	387.5
L4	148	173	185.5	198	223	235.5	248	260.5	285.5	298	310.5	335.5	348	360.5	373	398

# Gateway Decentralised System

## 5 Port Solenoid Valve

### Series VQC4000



For detailed specifications, Common Precautions and Specific Product Precautions, refer to the **WEB catalogue** or the VQC4000/5000 series catalogue (CAT. EUS11-108).

### How to Order Manifold

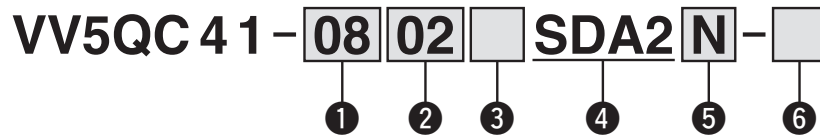

#### 1 Valve stations

Stations	Note
01	1 station
⋮	⋮
08	8 stations
01	1 station
⋮	⋮
16	16 stations

Double wiring

Mixed wiring, Specified layout <sup>Note)</sup>  
(Available up to 16 solenoids)

Note) Specified layout: Indicate the wiring specifications on the manifold specification sheet. (Note that 2-position double, 3-position and 4-position valves cannot be used where single wiring has been specified.) In addition, select the option "K".

#### 2 Cylinder port size

C6	With Ø 6 One-touch fitting
C8	With Ø 8 One-touch fitting
C10	With Ø 10 One-touch fitting
C12	With Ø 12 One-touch fitting
N7	Ø 1/4" One-touch fitting
N9	Ø 5/16" One-touch fitting
N11	Ø 3/8" One-touch fitting
02	1/4 <sup>Note)</sup>
03	3/8 <sup>Note)</sup>
B	Bottom ported 1/4 <sup>Note)</sup>
CM	Mixed sizes

Note) Compatible with Rc, G, NPT/NPTF.  
Part number displayed is as shown below.

#### 3 Thread type

—	Rc
F	G
N	NPT
T	NPTF

#### 4 SI Unit (Number of outputs, Max. number of valve stations)

SD0	Without SI Unit
SDA2	16 outputs, 1 to 8 stations (16 stations <sup>Note)</sup> )

Note) ( ) : Maximum number of stations for mixed single and double wiring.

#### 5 SI Unit (Output polarity)

—	Positive common
N	Negative common

\* Select "—" for without SI Unit.

#### 6 Option

—	None
K <sup>Note)</sup>	Special wiring specification (Except double wiring)

Note) When single wiring and double wiring are mixed, specify wiring type of each station on the manifold specification sheet.

**How to Order Valves**

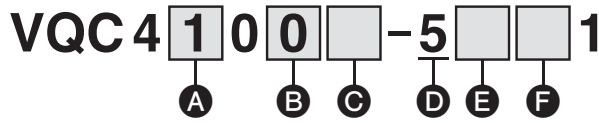

**A Type of actuation**

1	2-position single	4	3-position exhaust centre
2	2-position double	5	3-position pressure centre
3	3-position closed centre	6 (Note)	3-position double check

Note) For double check type, refer to the **WEB catalogue** or the VQC4000/5000 series catalogue (CAT. EUS11-108).

**B Seal type**

0	Metal seal
1	Rubber seal

**C Function**

— (Note 1)	Standard (0.95 W)
Y	Low wattage type (0.4 W)
R (Note 2)	External pilot

\* When multiple symbols are specified, indicate them alphabetically.

Note 1) When the power is energised continuously, refer to "Specific Product Precautions 1" in the **WEB catalogue** or the VQC4000/5000 series catalogue (CAT. EUS11-108).

Note 2) For details about the external pilot type, refer to the **WEB catalogue** or the VQ4000/5000 series catalogue (CAT. EUS11-104). In addition, an external pilot type cannot be combined with the double check spacer.

**D Coil voltage**

5	24 V DC
---	---------

**E Light/surge voltage suppressor**

—	With
E	Without light, with surge voltage suppressor

**F Manual override**

—	Non-locking push (tool required)	
B	Push-turn locking (tool required)	
C	Turn locking (manual)	

**How to Order Manifold Assembly**

**Example**

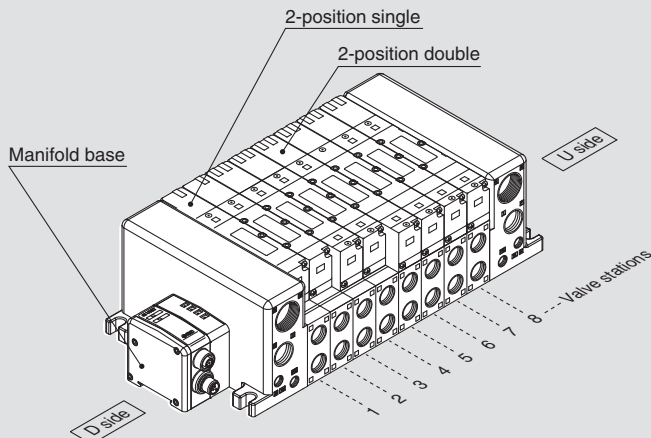

VV5QC41-0802SDA2N.....1 set (Manifold base part number)  
 \* VQC4100-51 .....4 sets (2-position single part number)  
 \* VQC4200-51 .....4 sets (2-position double part number)

The asterisk denotes the symbol for assembly. Prefix it to the part numbers of the valve etc.

- The valve arrangement is numbered as the 1st station from the D side.
- Under the manifold base part number, state the valves to be mounted in order from the 1st station as shown in the figure above. If the arrangement becomes complicated, specify on the manifold specification sheet.

# Series VQC4000

## Dimensions

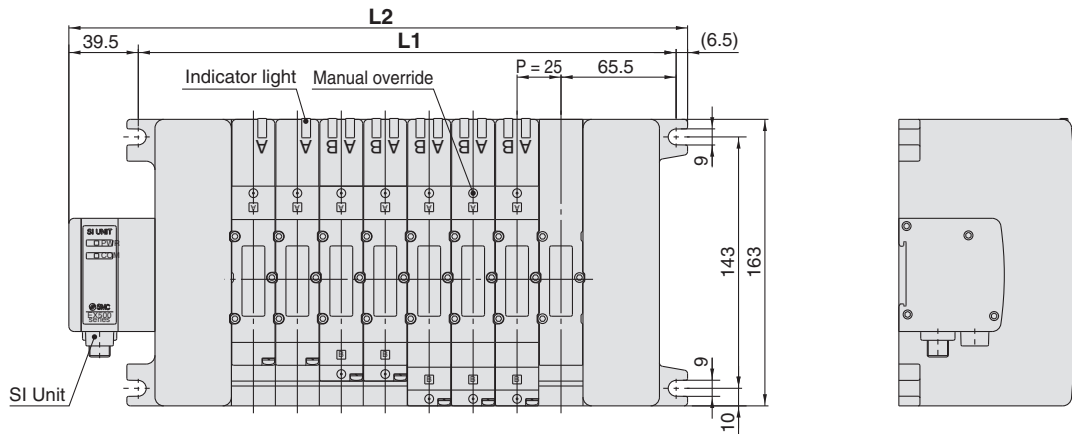
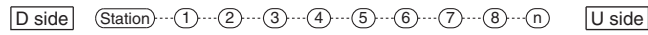
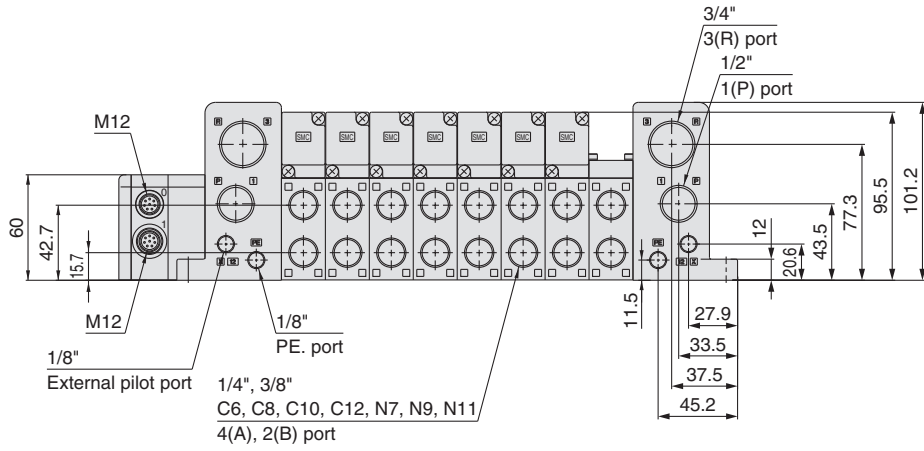

Formula:  $L1 = 25n + 106$ ,  $L2 = 25n + 152$  n: Stations (Maximum 16 stations)

L \ n	1	2	3	4	5	6	7	8	9	10	11	12	13	14	15	16
L1	131	156	181	206	231	256	281	306	331	356	381	406	431	456	481	506
L2	177	202	227	252	277	302	327	352	377	402	427	452	477	502	527	552



# Gateway Decentralised System

## 5 Port Solenoid Valve

### Series VQC5000



For detailed specifications, Common Precautions and Specific Product Precautions, refer to the **WEB catalogue** or the VQC4000/5000 series catalogue (CAT. EUS11-108).

### How to Order Manifold

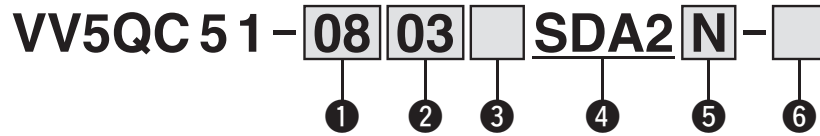

#### 1 Valve stations

	Stations	Note
01	1 station	Double wiring
⋮	⋮	
08	8 stations	Mixed wiring, Specified layout <sup>Note)</sup> (Available up to 12 solenoids)
01	1 station	
⋮	⋮	
12	12 stations	

Note) Specified layout: Indicate the wiring specifications on the manifold specification sheet. (Note that 2-position double, 3-position and 4-position valves cannot be used where single wiring has been specified.) In addition, select the option "K".

#### 2 Cylinder port size

03	3/8 <sup>Note)</sup>
04	1/2 <sup>Note)</sup>
B	Bottom ported 1/4 <sup>Note)</sup>
CM	Mixed sizes

Note) Compatible with Rc, G, NPT/NPTF.  
Part number displayed is as shown below.

#### 3 Thread type

—	Rc
F	G
N	NPT
T	NPTF

#### 4 SI Unit (Number of outputs, Max. number of valve stations)

SD0	Without SI Unit
SDA2	16 outputs, 1 to 8 stations (12 stations <sup>Note)</sup> )

Note) ( ): Maximum number of stations for mixed single and double wiring.

#### 5 SI Unit (Output polarity)

—	Positive common
N	Negative common

\* Select "—" for without SI Unit.

#### 6 Option

—	None
K <sup>Note)</sup>	Special wiring specification (Except double wiring)

Note) When single wiring and double wiring are mixed, specify wiring type of each station on the manifold specification sheet.

## How to Order Valves

VQC5 **1** **0** **0** **□** - **5** **□** **□** **1**

A
B
C
D
E
F

### A Type of actuation

<b>1</b>	2-position single	<b>4</b>	3-position exhaust centre
<b>2</b>	2-position double	<b>5</b>	3-position pressure centre
<b>3</b>	3-position closed centre	<b>6</b> (Note)	3-position double check

Note) For double check type, refer to the **WEB catalogue** or the VQC4000/5000 series catalogue (CAT. EUS11-108).

### B Seal type

<b>0</b>	Metal seal
<b>1</b>	Rubber seal

### C Function

— (Note 1)	Standard (0.95 W)
<b>Y</b> (Note 1)	Low wattage type (0.4 W)
<b>R</b> (Note 2)	External pilot

\* When multiple symbols are specified, indicate them alphabetically.

Note 1) When the power is energised continuously, refer to "Specific Product Precautions 1" in the **WEB catalogue** or the VQC4000/5000 series catalogue (CAT. EUS11-108).

Note 2) For details about the external pilot type, refer to the **WEB catalogue** or the VQ4000/5000 series catalogue (CAT. EUS11-104). In addition, an external pilot type cannot be combined with the double check spacer.

### D Coil voltage

<b>5</b>	24 V DC
----------	---------

### E Light/surge voltage suppressor

—	With
<b>E</b>	Without light, with surge voltage suppressor

### F Manual override

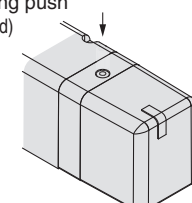
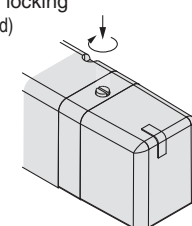
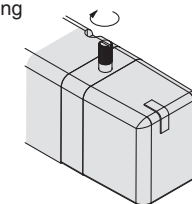
—	Non-locking push (tool required)	
<b>B</b>	Push-turn locking (tool required)	
<b>C</b>	Turn locking (manual)	

## How to Order Manifold Assembly

### Example

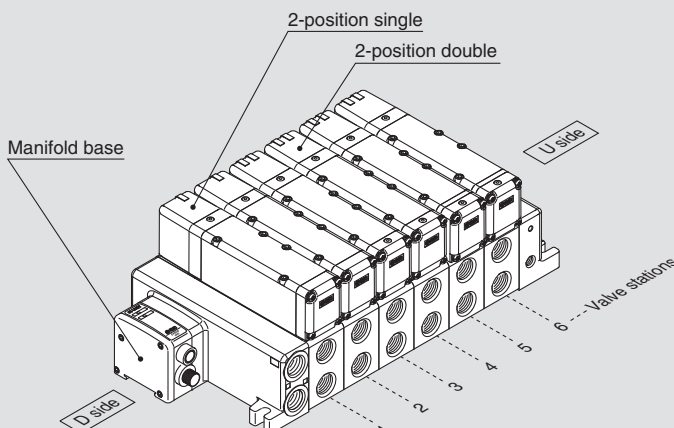

VVQC51-0603SDA2N .....1 set (Manifold base part number)  
 \* VQC5100-51 .....2 sets (2-position single part number)  
 \* VQC5200-51 .....2 sets (2-position double part number)  
 \* VQC5300-51 .....2 sets (3-position closed centre part number)

↳ The asterisk denotes the symbol for assembly. Prefix it to the part numbers of the valve etc.

- The valve arrangement is numbered as the 1st station from the D side.
- Under the manifold base part number, state the valves to be mounted in order from the 1st station as shown in the figure above. If the arrangement becomes complicated, specify on the manifold specification sheet.

Dimensions

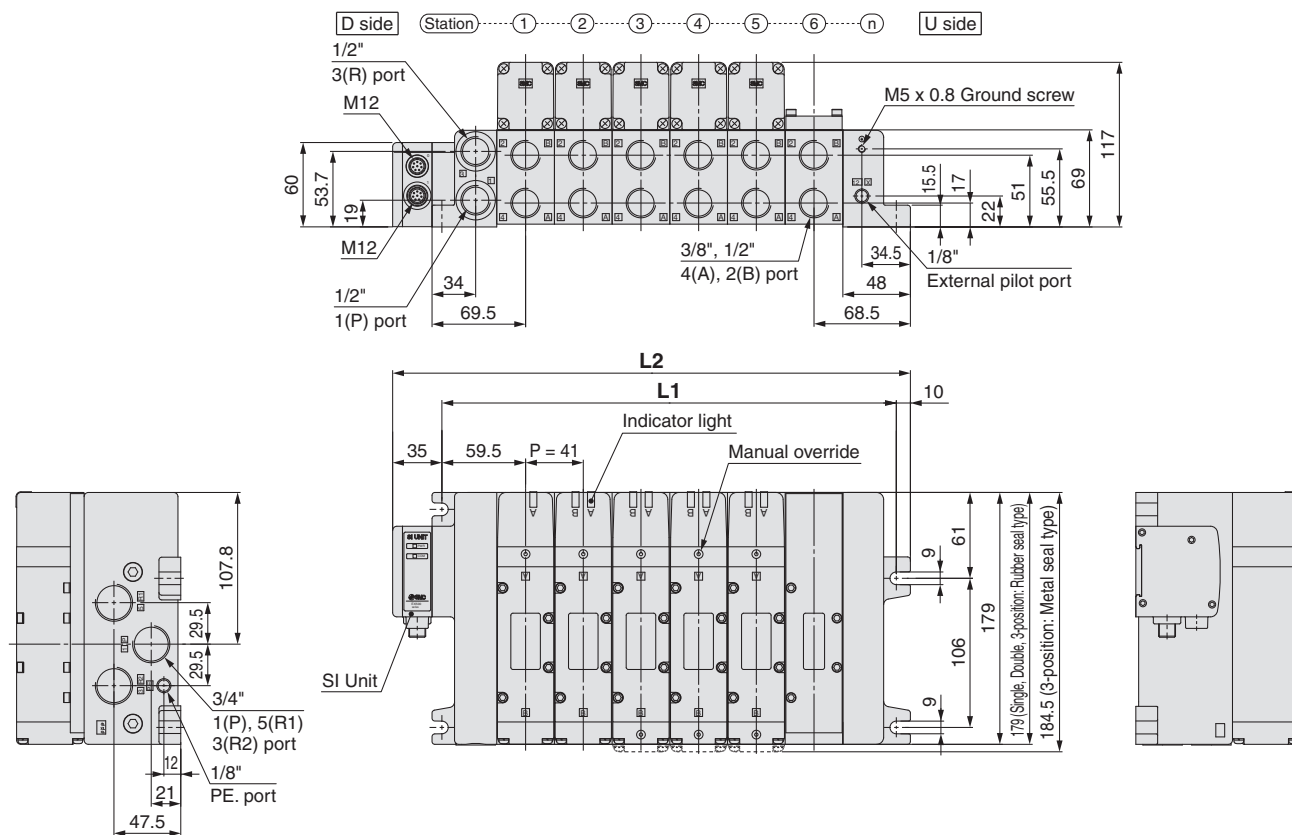

Formula: L1 = 41n + 77, L2 = 41n + 122 n: Stations (Maximum 12 stations)

L \ n	1	2	3	4	5	6	7	8	9	10	11	12
<b>L1</b>	118	159	200	241	282	323	364	405	446	487	528	569
<b>L2</b>	163	204	245	286	327	368	409	450	491	532	573	614

Gateway Decentralised System

SY

VQC

S0700

SV

# Gateway Decentralised System

## 5 Port Solenoid Valve

### Series S0700



For detailed specifications, Common Precautions and Specific Product Precautions, refer to the **WEB catalogue** or the S0700 series catalogue (CAT. EUS11-88).

### How to Order Manifold

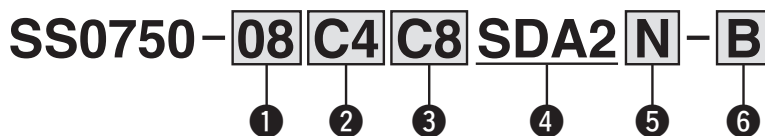

#### 1 Valve stations

	Stations	Note
<b>01</b>	1 station	Double wiring
⋮	⋮	
<b>08</b>	8 stations	Mixed wiring, Specified layout <sup>Note)</sup> (Available up to 16 solenoids)
<b>01</b>	1 station	
⋮	⋮	
<b>16</b>	16 stations	

Note) Specified layout: Indicate the wiring specifications on the manifold specification sheet. (Note that 2-position double, 3-position and 4-position valves cannot be used where single wiring has been specified.) In addition, select the option "K".

#### 2 A, B port size

##### Metric size

<b>C2</b>	Ø 2 One-touch fitting
<b>C3</b>	Ø 3.2 One-touch fitting
<b>C4</b>	Ø 4 One-touch fitting
<b>CM</b> <sup>Note)</sup>	Mixed sizes and with port plug

##### Inch size

<b>N1</b>	Ø 1/8" One-touch fitting
<b>N3</b>	Ø 5/32" One-touch fitting
<b>NM</b> <sup>Note)</sup>	Mixed sizes and with port plug

Note) Indicate the sizes on the manifold specification sheet.

#### 3 P, R port size

##### Metric size

—	Ø 8 One-touch fitting <sup>Note)</sup>
<b>C6</b>	Ø 6 One-touch fitting
<b>C8</b>	Ø 8 One-touch fitting

##### Inch size

<b>N7</b>	Ø 1/4" One-touch fitting
<b>N9</b>	Ø 5/16" One-touch fitting

Note) When A and B ports are inch size, the One-touch fitting will be changed to Ø 5/16".

#### 4 SI Unit (Number of outputs, Max. number of valve stations)

<b>SD0</b>	Without SI Unit
<b>SDA2</b>	16 outputs, 1 to 8 stations (16 stations) <sup>Note)</sup>

Note) ( ): Maximum number of stations for mixed single and double wiring.

#### 5 SI Unit (Output polarity)

—	Positive common
<b>N</b>	Negative common

\* Ensure a match with the common specification of the valve to be used.

\* Select "—" for without SI Unit.

#### 6 Option

—	None
<b>B</b> <sup>Note 1)</sup>	With back pressure check valve (All stations)
<b>D</b>	With DIN bracket, DIN rail with standard length
<b>D0</b>	With DIN bracket, without DIN rail
<b>D□</b> <sup>Note 2)</sup>	With DIN bracket, DIN rail for □ stations
<b>K</b> <sup>Note 3)</sup>	Special wiring specification (Except double wiring)
<b>N</b>	With name plate
<b>R</b> <sup>Note 4)</sup>	External pilot
<b>S</b>	Built-in silencer

\* When multiple symbols are specified, indicate them alphabetically. Example) "BKN"

Note 1) When a back pressure check valve is used only for specified station, specify the back pressure check valve part number, and specify the station number to which the valve is mounted, on the manifold specification sheet.

Note 2) □: Specify a longer rail than the length of valve stations.  
Example) "D08"

In this case, the valves will be mounted on the DIN rail for 8 stations, regardless of the number of manifold stations.

Note 3) When single wiring and double wiring are mixed, specify wiring type of each station on the manifold specification sheet.

Note 4) For external pilot option "R", indicate the external pilot specification "R" for the applicable valves as well.

### How to Order Valves

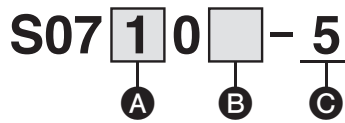

**A** Type of actuation

<b>1</b>	2-position single
<b>2</b>	2-position double
<b>A</b> (Note)	4-position dual 3-port (N.C. + N.C.) [Exhaust centre]
<b>B</b> (Note)	4-position dual 3-port (N.O. + N.O.) [Pressure centre]
<b>C</b> (Note)	4-position dual 3-port (N.C. + N.O.)

(Note) For 4-position dual 3-port, select “—” internal pilot.

**B** Function

—	Internal pilot
<b>R</b> (Note)	External pilot

(Note) For external pilot, select “1” 2-position single or “2” 2-position double.

**C** Rated voltage

<b>5</b>	24 V DC
----------	---------

### How to Order Manifold Assembly

**Example**

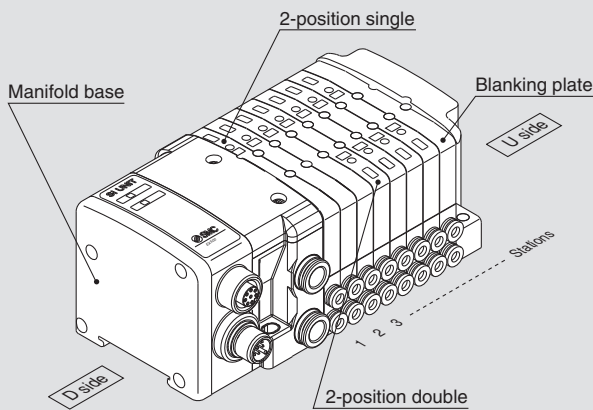

SS0750-08C4SDA2.....1 set (Manifold base part number)  
 \* S0710-5.....3 sets (2-position single part number)  
 \* S0720-5.....4 sets (2-position double part number)  
 \* SS0700-10A-1.....1 set (Blanking plate part number)  
 ↳ The asterisk denotes the symbol for assembly.  
 Prefix it to the part numbers of the valve etc.

- The valve arrangement is numbered as the 1st station from the D side.
- Under the manifold base part number, state the valves to be mounted in order from the 1st station as shown in the figure above. If the arrangement becomes complicated, specify on the manifold specification sheet.

# Series S0700

## Dimensions

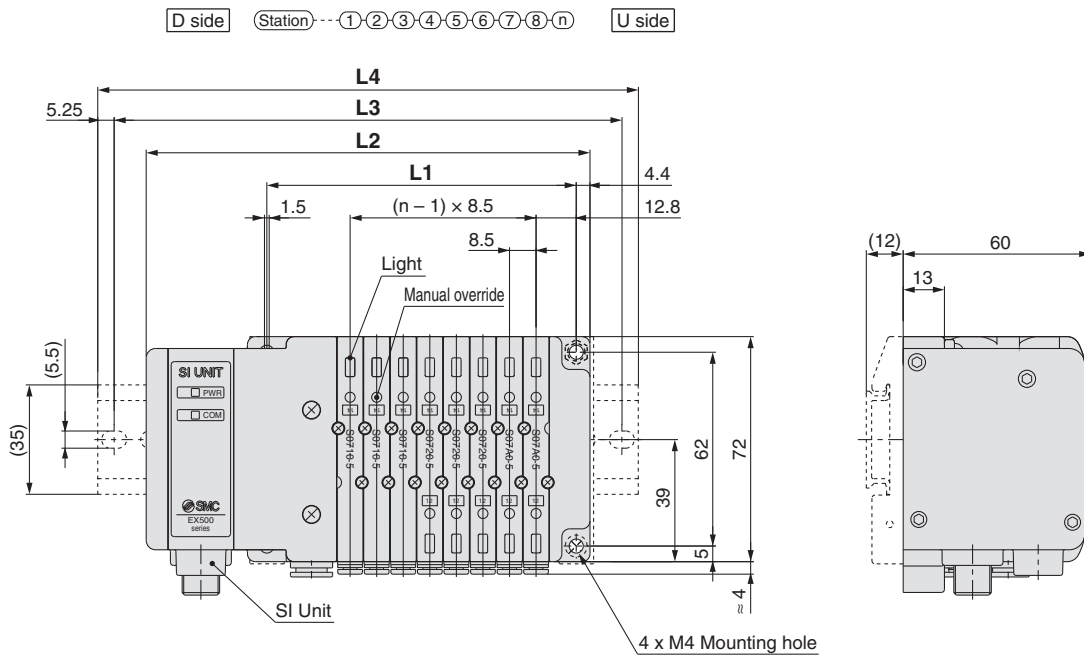
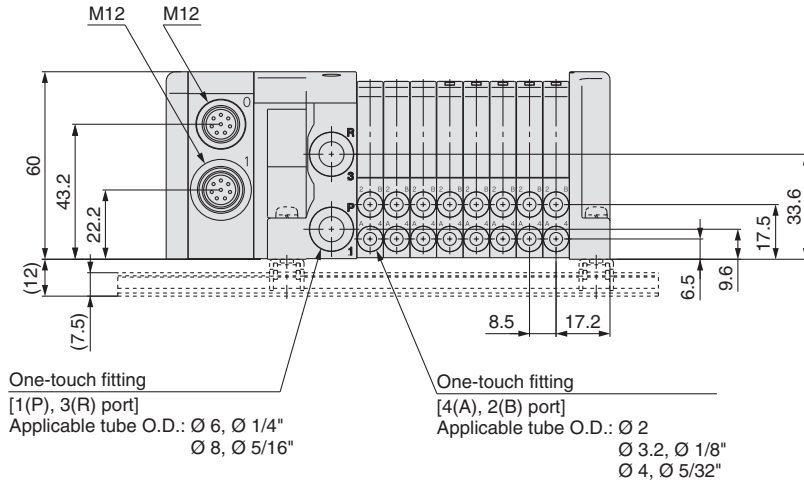

### Dimensions

Formula:  $L1 = 8.5n + 31$ ,  $L2 = 8.5n + 74$  n: Stations (Maximum 16 stations)

L \ n	2	3	4	5	6	7	8	9	10	11	12	13	14	15	16
L1	48	56.5	65	73.5	82	90.5	99	107.5	116	124.5	133	141.5	150	158.5	167
L2	91	99.5	108	116.5	125	133.5	142	150.5	159	167.5	176	184.5	193	201.5	210
L3	112.5	125	137.5	137.5	150	162.5	162.5	175	187.5	187.5	200	212.5	212.5	225	237.5
L4	123	135.5	148	148	160.5	173	173	185.5	198	198	210.5	223	223	235.5	248

# Gateway Decentralised System

## 5 Port Solenoid Valve

Series **SV1000/2000/3000/4000**



For detailed specifications, Common Precautions and Specific Product Precautions, refer to the **WEB catalogue** or the SV series catalogue (CAT. EUS11-81).

### How to Order Manifold

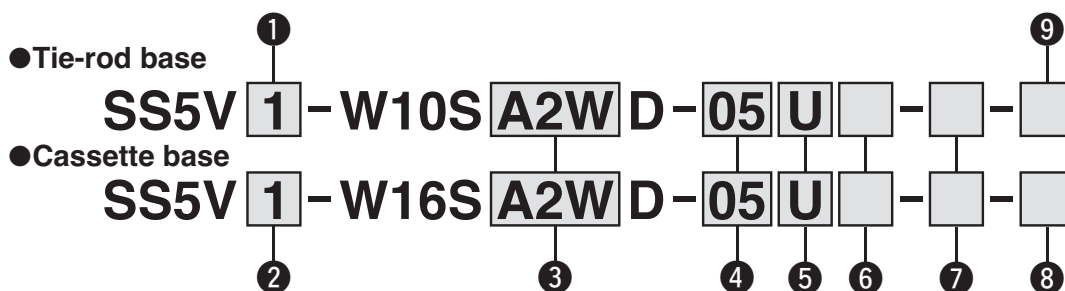

#### 1 Series

1	SV1000
2	SV2000
3	SV3000
4	SV4000

#### 2 Series

1	SV1000
2	SV2000

#### 3 SI Unit (Number of outputs, Output polarity, Max. number of valve stations)

0	Without SI Unit
A2W	16 outputs, Positive common, 1 to 8 stations (Note)

Note) ( ): Maximum number of stations for mixed single and double wiring.

#### 4 Valve stations

Stations	Note
02	2 stations
⋮	⋮
08	8 stations
02	2 stations
⋮	⋮
16	16 stations

Mixed wiring, Specified layout (Note 2)  
(Available up to 16 solenoids)

Note 1) Double wiring: single, double, 3-position and 4-position valves can be used on all manifold stations.

Use of a single solenoid will result in an unused control signal. If this is not desired, order with a specified layout.

Note 2) Specified layout: Indicate the wiring specifications on the manifold specification sheet. (Note that double, 3-position and 4-position valves cannot be used where single wiring has been specified.)

#### 5 P, E port entry

U	U side (2 to 10 stations)
D	D side (2 to 10 stations)
B	Both sides (2 to 16 stations)

#### 6 SUP/EXH block assembly

-	Internal pilot
S	Internal pilot, Built-in silencer (Note)
R	External pilot
RS	External pilot, Built-in silencer (Note)

Note) When the built-in silencer type is used, keep the exhaust port from coming in direct contact with water or other liquids.

#### 8 DIN rail length specified

-	With DIN bracket, DIN rail with standard length
3 (Note)	With DIN bracket, DIN rail for 3 stations
⋮	⋮
16 (Note)	With DIN bracket, DIN rail for 16 stations

Note) Specify a longer rail than the length of valve stations.

\* If the DIN rail must be mounted without an SI Unit, select "D0" and order the DIN rail separately. Refer to L3 of the dimensions for the DIN rail length. For the DIN rail part number, refer to the **WEB catalogue** or the SY series catalogue (CAT. EUS11-103).

#### 7 A, B port size

##### Metric size

Symbol	A, B port	P, E port	Applicable series
C3	Ø 3.2 One-touch fitting	Ø 8 One-touch fitting	SV1000
C4	Ø 4 One-touch fitting		
C6	Ø 6 One-touch fitting	Ø 10 One-touch fitting	SV2000
C4	Ø 4 One-touch fitting		
C6	Ø 6 One-touch fitting	Ø 12 One-touch fitting	SV3000
C8	Ø 8 One-touch fitting		
C10	Ø 10 One-touch fitting	Ø 12 One-touch fitting	SV4000
C8	Ø 8 One-touch fitting		
C10	Ø 10 One-touch fitting		
C12	Ø 12 One-touch fitting		
02	Rc1/4	Rc3/8	SV4000
03	Rc3/8		
02F	G1/4	G3/8	SV4000
03F	G3/8		
M (Note)	A, B port mixed		

Note) Indicate the sizes on the manifold specification sheet.

\* The X and PE port size of external pilot type [R, RS] are Ø 4 (mm) or Ø 5/32" (inch) for the SV1000/2000 series, and Ø 6 (mm) or Ø 1/4" (inch) for the SV3000/4000 series.

#### 9 Mounting

-	Direct mounting
D	With DIN bracket, DIN rail with standard length
D0	With DIN bracket, without DIN rail
D3 (Note)	With DIN bracket, DIN rail for 3 stations
⋮	⋮
D16 (Note)	With DIN bracket, DIN rail for 16 stations

Note) Specify a longer rail than the length of valve stations.

\* If the DIN rail must be mounted without an SI Unit, select "D0" and order the DIN rail separately. Refer to L3 of the dimensions for the DIN rail length. For the DIN rail part number, refer to the **WEB catalogue** or the SV series catalogue (CAT. EUS11-81).

# Series SV1000/2000/3000/4000

## How to Order Valves

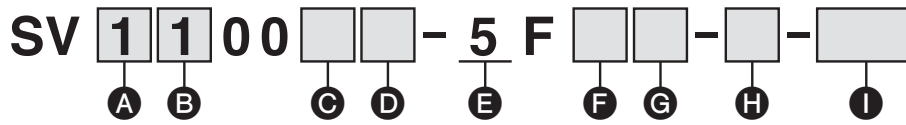

### A Series

1	SV1000
2	SV2000
3	SV3000
4	SV4000

### B Type of actuation

1	2-position single
2	2-position double
3	3-position closed centre
4	3-position exhaust centre
5	3-position pressure centre
<b>A</b> (Note)	4-position dual 3-port valve (N.C./N.C.)
<b>B</b> (Note)	4-position dual 3-port valve (N.O./N.O.)
<b>C</b> (Note)	4-position dual 3-port valve (N.C./N.O.)

Note) Select the SV1000 or SV2000 series for the 4-position dual 3-port valve.  
 \* Select the internal pilot type for the 4-position dual 3-port valve.

### C Pilot type

—	Internal pilot
R	External pilot

### D Back pressure check valve

—	None
K	Built-in

\* Built-in back pressure check valve type is applicable to the SV1000 series only.  
 \* The product with a back pressure check valve is not available for 3-position valves.  
 \* Refer to the **WEB catalogue** for built-in back pressure check valve type.

### E Rated voltage

5	24 V DC
---	---------

### F Light/surge voltage suppressor

U	With light/surge voltage suppressor
R	Without light, with surge voltage suppressor

### G Manual override

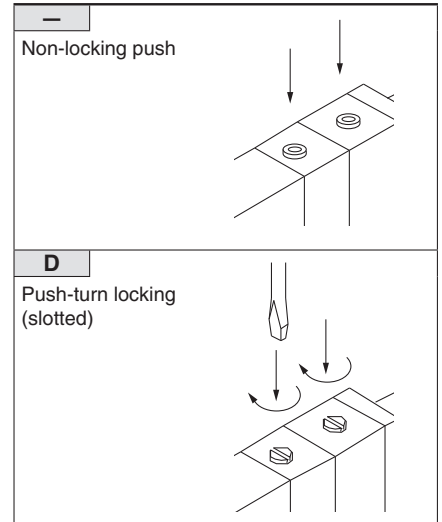

### H Manifold block

If stations are to be added, order the product with manifold block.  
 (For details, refer to the **WEB catalogue**.)

### I Made to Order

—	—
X90	Main valve fluororubber specification (For details, refer to the <b>WEB catalogue</b> .)

## How to Order Manifold Assembly

### Example

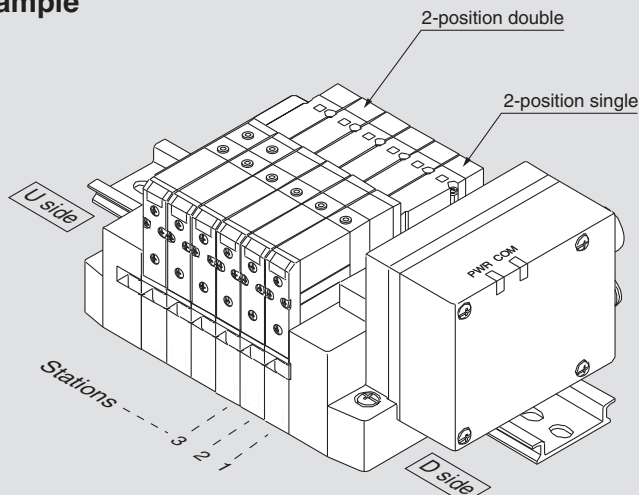

SS5V1-W16SA2WD-06B-C6.....1 set (Manifold base part number)  
 \* SV1100-5FU .....4 sets (2-position single part number)  
 \* SV1200-5FU .....2 sets (2-position double part number)

The asterisk denotes the symbol for assembly.  
 Prefix it to the part numbers of the valve etc.

- The valve arrangement is numbered as the 1st station from the D side.
- Under the manifold base part number, state the valves to be mounted in order from the 1st station as shown in the figure above. If the arrangement becomes complicated, specify on the manifold specification sheet.



## Dimensions

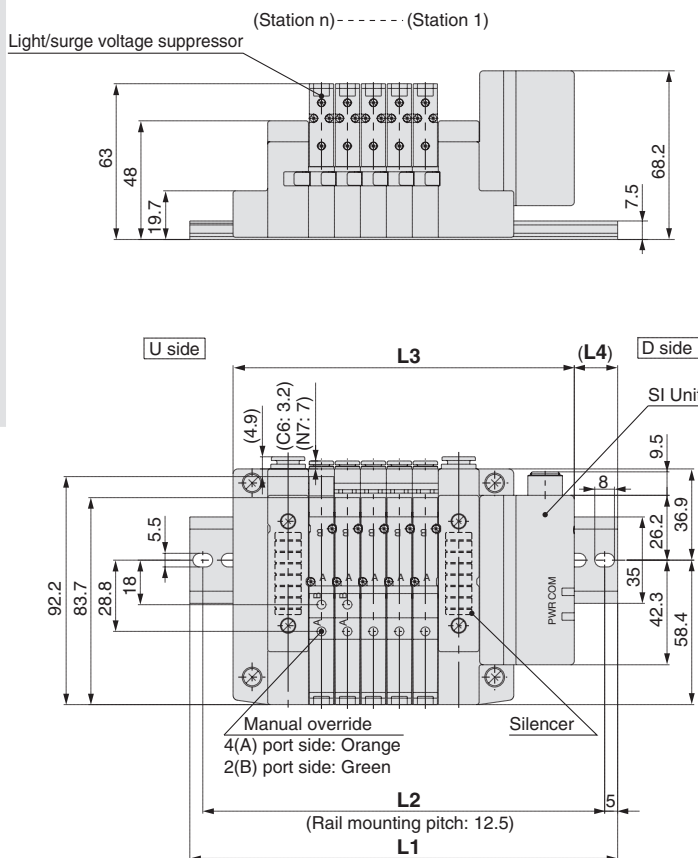
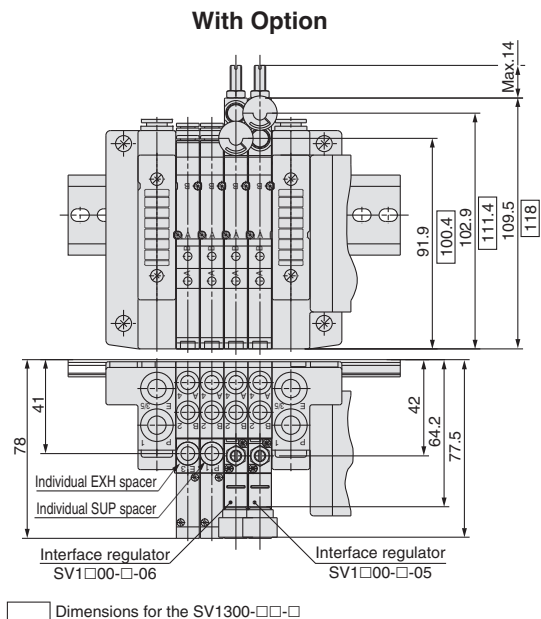

## With External Pilot Specification

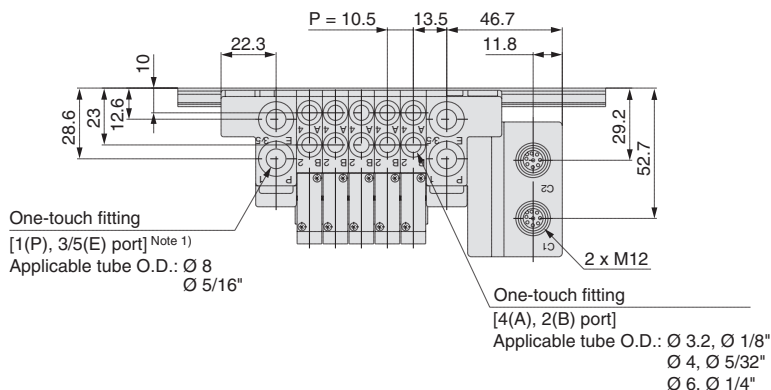
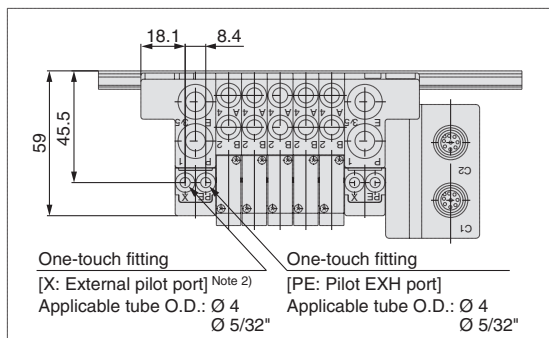

Note 1) When P, E port outlets are indicated on the U side or D side, the P, E ports on the opposite side are plugged.

Note 2) External pilot port positions and silencer discharge port positions are the same as P, E port outlet positions.

## L: Dimensions

L	n	n: Stations															
		2	3	4	5	6	7	8	9	10	11	12	13	14	15	16	
L1		135.5	148	160.5	173	173	185.5	198	210.5	223	235.5	235.5	248	260.5	273	285.5	
L2		125	137.5	150	162.5	162.5	175	187.5	200	212.5	225	225	237.5	250	262.5	275	
L3		106.5	117	127.5	138	148.5	159	169.5	180	190.5	201	211.5	222	232.5	243	253.5	
L4		14.5	15.5	16.5	17.5	12.5	13.5	14.5	15.5	16.5	17.5	12	13	14	15	16	

# Series SV2000

## Dimensions

Cassette Base Series SV2000

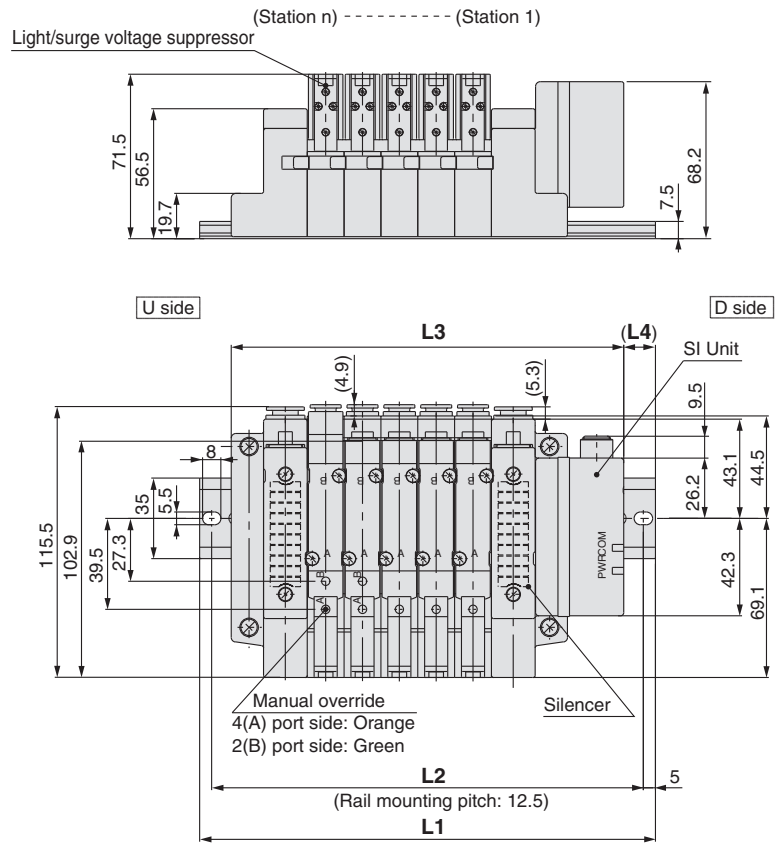
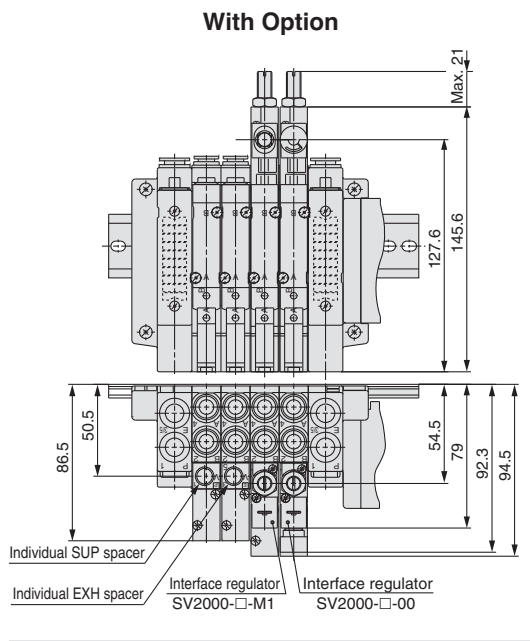

### With External Pilot Specification

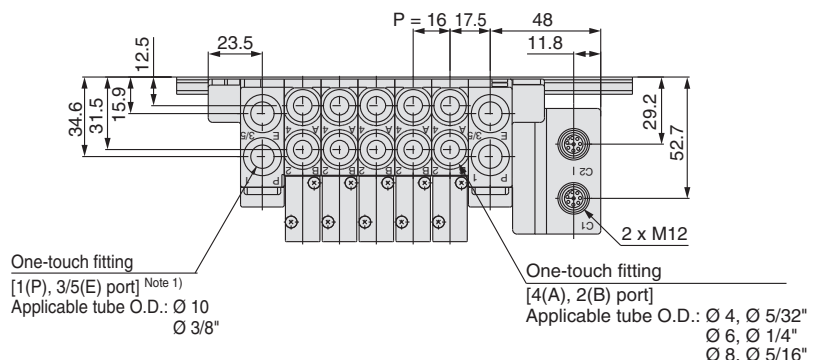
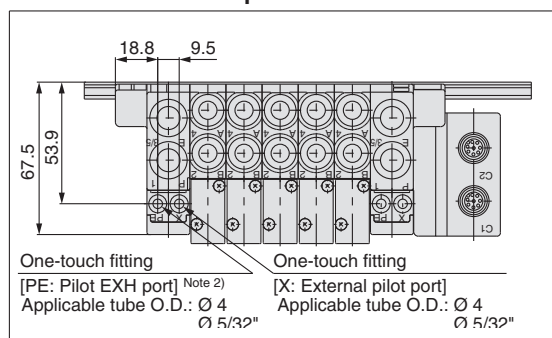

Note 1) When P, E port outlets are indicated on the U side or D side, the P, E ports on the opposite side are plugged.  
Note 2) External pilot port positions and silencer discharge port positions are the same as P, E port outlet positions.

### L: Dimensions

L	n	2	3	4	5	6	7	8	9	10	11	12	13	14	15	16
L1	n: Stations	148	173	185.5	198	210.5	235.5	248	260.5	285.5	298	310.5	323	348	360.5	373
L2		137.5	162.5	175	187.5	200	225	237.5	250	275	287.5	300	312.5	337.5	350	362.5
L3		122.5	138.5	154.5	170.5	186.5	202.5	218.5	234.5	250.5	266.5	282.5	298.5	314.5	330.5	346.5
L4		13	17.5	15.5	14	12	16.5	15	13	17.5	16	14	12.5	17	15	13.5

## Dimensions

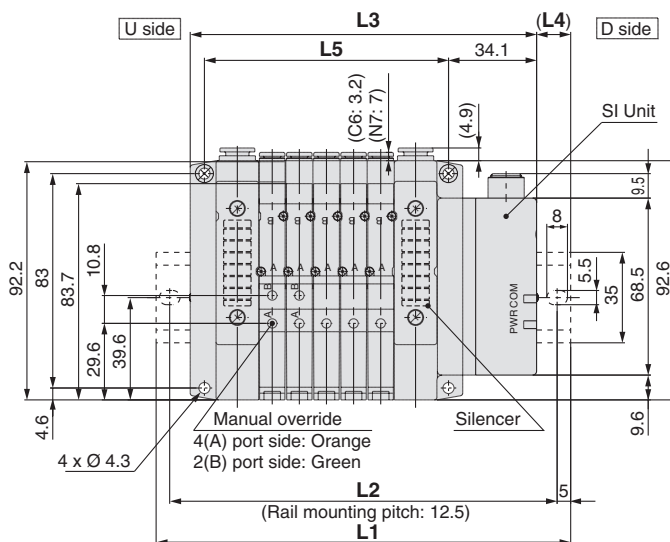
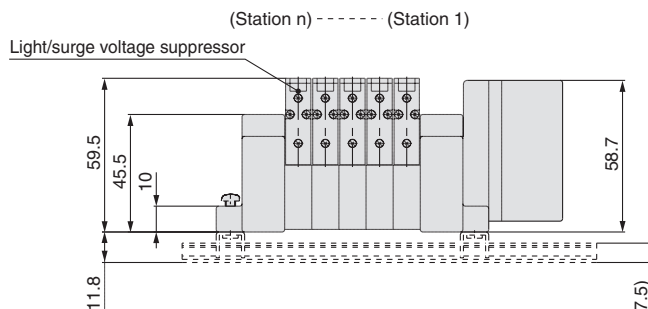
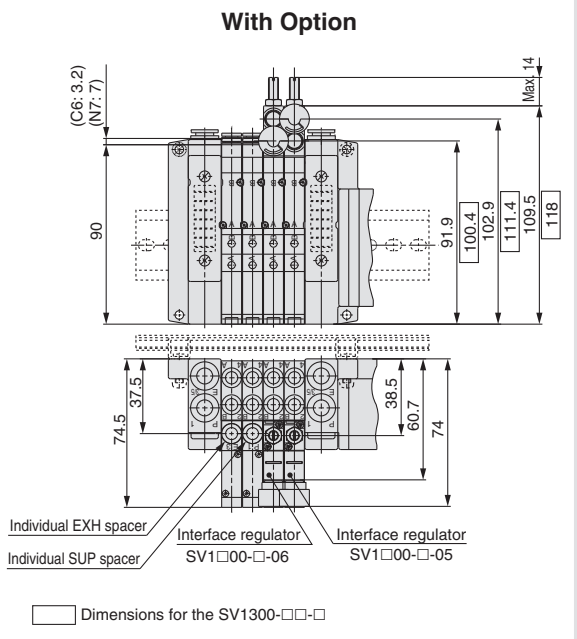

## With External Pilot Specification

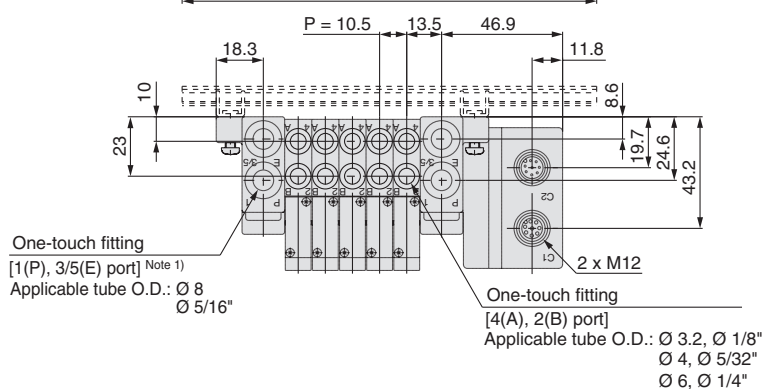
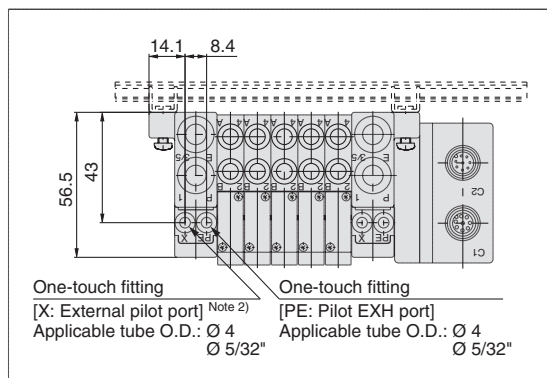

Note 1) When P, E port outlets are indicated on the U side or D side, the P, E ports on the opposite side are plugged.  
Note 2) External pilot port positions and silencer discharge port positions are the same as P, E port outlet positions.

## L: Dimensions

L \ n	2	3	4	5	6	7	8	9	10	11	12	13	14	15	16
L1	135.5	148	148	160.5	173	185.5	198	210.5	210.5	223	235.5	248	260.5	273	273
L2	125	137.5	137.5	150	162.5	175	187.5	200	200	212.5	225	237.5	250	262.5	262.5
L3	102.6	113.1	123.6	134.1	144.6	155.1	165.6	176.1	186.6	197.1	207.6	218.1	228.6	239.1	249.6
L4	16.5	17.5	12	13	14	15	16	17	12	13	14	15	16	17	11.5
L5	63	73.5	84	94.5	105	115.5	126	136.5	147	157.5	168	178.5	189	199.5	210

n: Stations

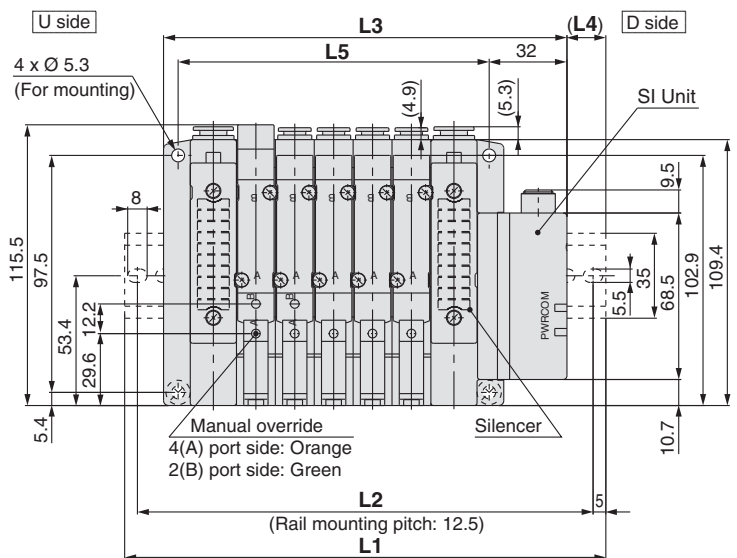
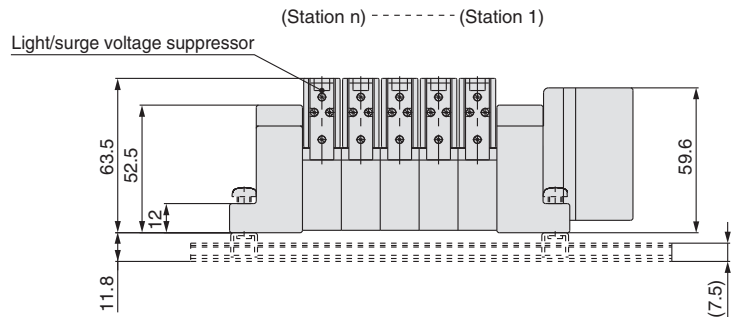
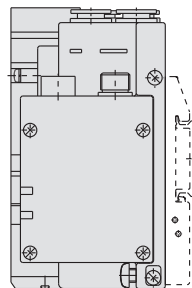
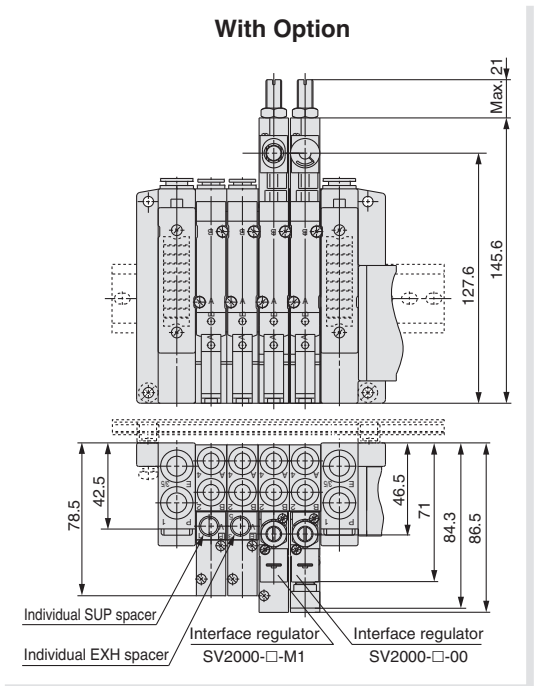

### With External Pilot Specification

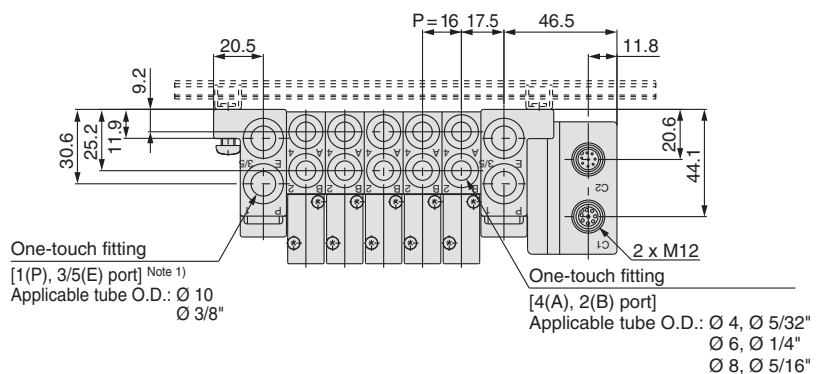
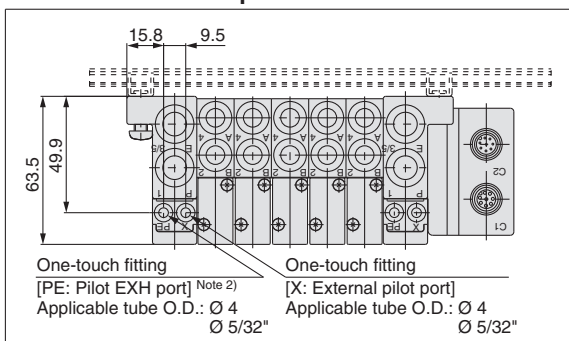

Note 1) When P, E port outlets are indicated on the U side or D side, the P, E ports on the opposite side are plugged.  
Note 2) External pilot port positions and silencer discharge port positions are the same as P, E port outlet positions.

### L: Dimensions

L	n	2	3	4	5	6	7	8	9	10	11	12	13	14	15	16
L1	n	148	160.5	185.5	198	210.5	223	248	260.5	273	285.5	310.5	323	335.5	360.5	373
L2		137.5	150	175	187.5	200	212.5	237.5	250	262.5	275	300	312.5	325	350	362.5
L3		118	134	150	166	182	198	214	230	246	262	278	294	310	326	342
L4		15	13.5	18	16	14.5	12.5	17	15.5	13.5	12	16.5	14.5	13	17.5	15.5
L5		80	96	112	128	144	160	176	192	208	224	240	256	272	288	304

## Dimensions

Tie-rod Base Series SV3000

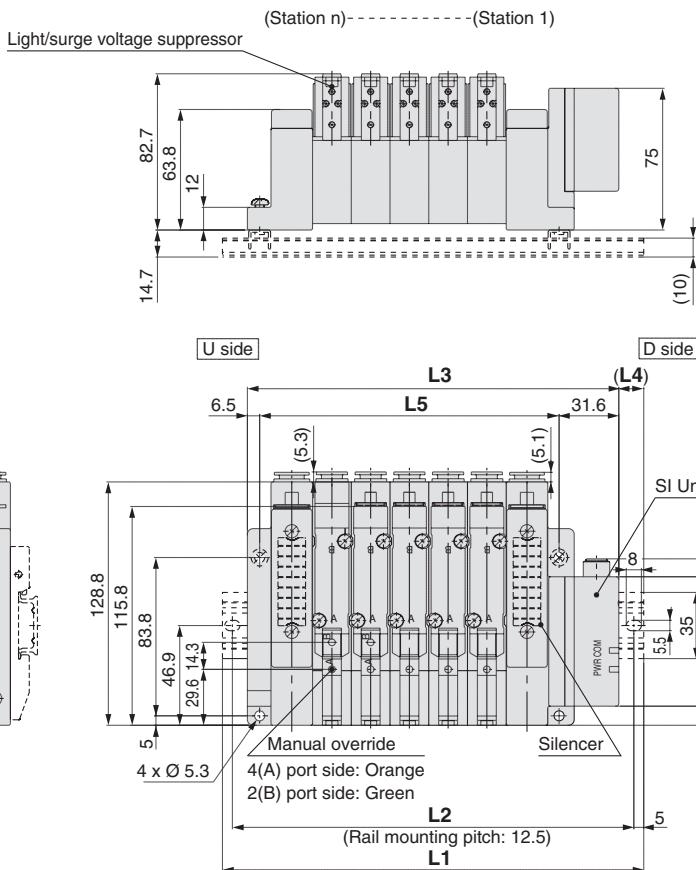
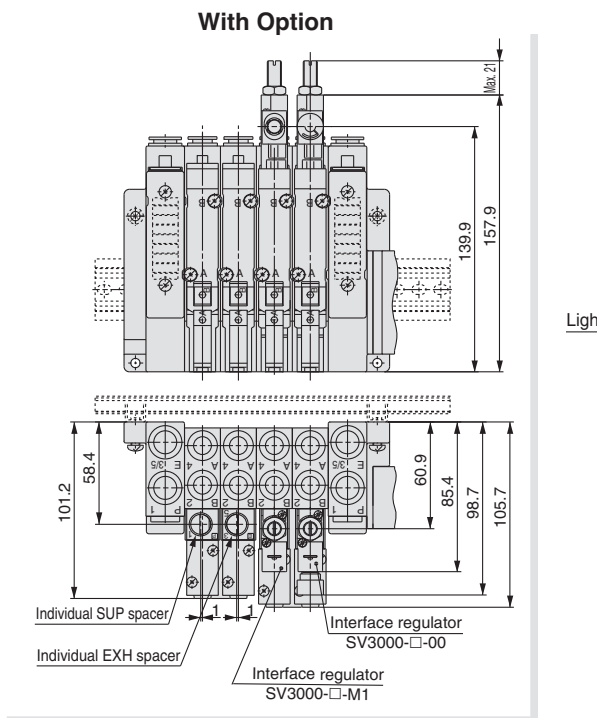

### With External Pilot Specification

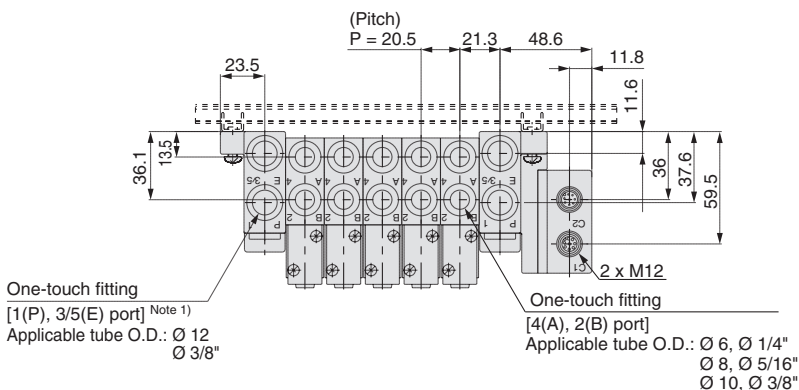
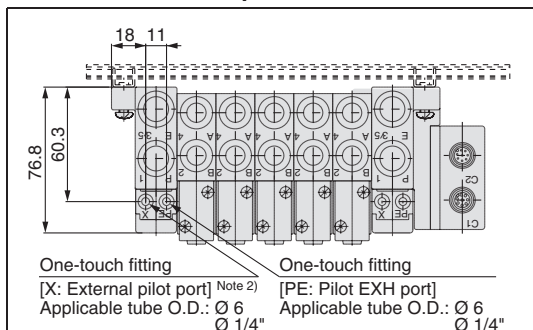

Note 1) When P, E port outlets are indicated on the U side or D side, the P, E ports on the opposite side are plugged.

Note 2) External pilot port positions and silencer discharge port positions are the same as P, E port outlet positions.

### L: Dimensions

n: Stations

L \ n	2	3	4	5	6	7	8	9	10	11	12	13	14	15	16
L1	160.5	185.5	210.5	223	248	273	285.5	310.5	323	348	373	385.5	410.5	435.5	448
L2	150	175	200	212.5	237.5	262.5	275	300	312.5	337.5	362.5	375	400	425	437.5
L3	135.1	155.6	176.1	196.6	217.1	237.6	258.1	278.6	299.1	319.6	340.1	360.6	381.1	401.6	422.1
L4	12.5	15	17	13	15.5	17.5	13.5	16	12	14	16.5	12.5	14.5	17	13
L5	97	117.5	138	158.5	179	199.5	220	240.5	261	281.5	302	322.5	343	363.5	384

# Series SV4000

## Dimensions

Tie-rod Base Series SV4000

With Option

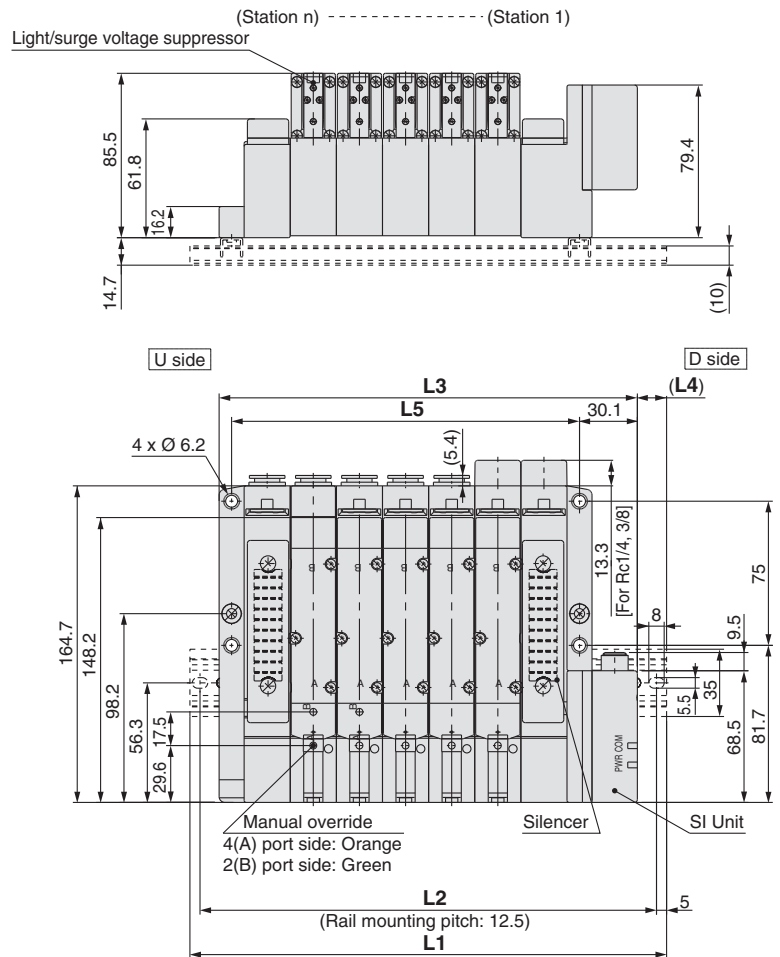
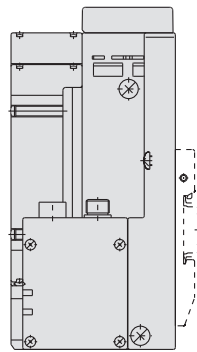
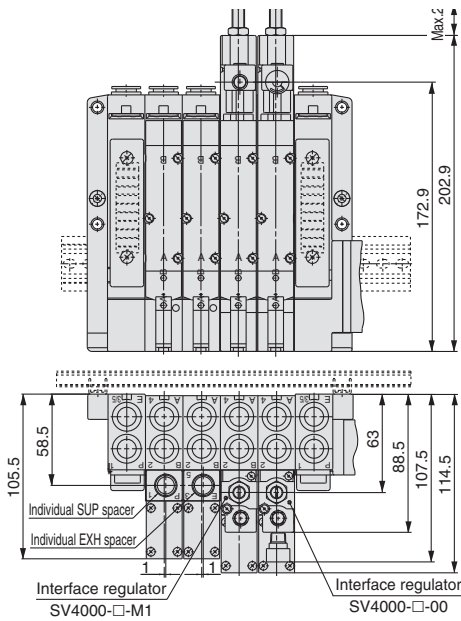

With External Pilot Specification

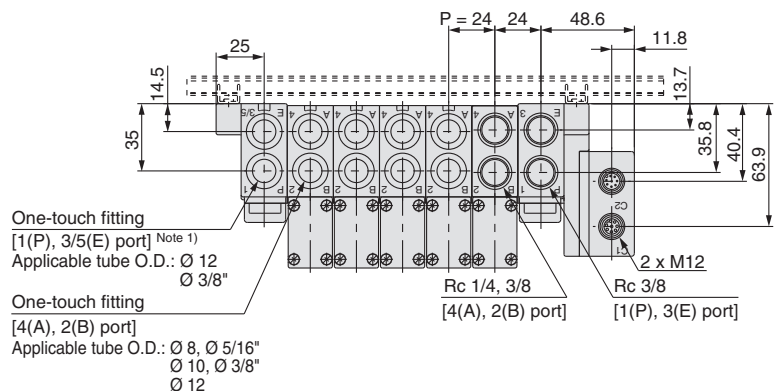
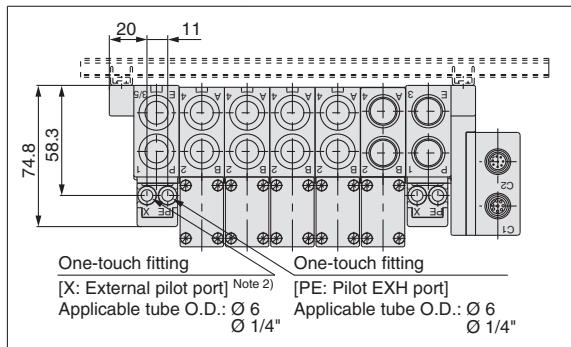

Note 1) When P, E port outlets are indicated on the U side or D side, the P, E ports on the opposite side are plugged.  
 Note 2) External pilot port positions and silencer discharge port positions are the same as P, E port outlet positions.

### L: Dimensions

L	n	2	3	4	5	6	7	8	9	10	11	12	13	14	15	16
L1	n	173	198	223	248	273	298	323	348	373	385.5	410.5	435.5	460.5	485.5	510.5
L2	n	162.5	187.5	212.5	237.5	262.5	287.5	312.5	337.5	362.5	375	400	425	450	475	500
L3	n	145.6	169.6	193.6	217.6	241.6	265.6	289.6	313.6	337.6	361.6	385.6	409.6	433.6	457.6	481.6
L4	n	13.5	14	14.5	15	15.5	16	16.5	17	17.5	12	12.5	13	13.5	14	14.5
L5	n	109	133	157	181	205	229	253	277	301	325	349	373	397	421	445



## Series EX500

# Specific Product Precautions 1

Be sure to read this before handling. Refer to the back cover for Safety Instructions. For 3/4/5 Port Solenoid Valve Precautions, refer to “Handling Precautions for SMC Products” and the Operation Manual on the SMC website, <http://www.smc.eu>

### Design / Selection

#### Warning

- 1. Do not use beyond the specification range.**  
Using beyond the specification range can cause a fire, malfunction, or damage to the system.  
Check the specifications before operation.
- 2. When using for an interlock circuit:**
  - **Provide a multiple interlock system which is operated by another system (such as mechanical protection function).**
  - **Perform an inspection to confirm that it is working properly.**  
Otherwise, this may cause possible injuries due to malfunction.

#### Caution

- 1. When applicable to UL, use a Class 2 power supply unit conforming to UL1310 for direct current power supply.**
- 2. Use within the specified voltage range.**  
Using beyond the specified voltage range is likely to cause the product to be damaged or to malfunction.
- 3. Do not install in places where it can be used as a foothold.**  
Applying any excessive load such as stepping on the product by mistake or placing a foot on it, will cause it to break.
- 4. Keep the surrounding space free for maintenance.**  
When designing a system, take into consideration the amount of free space needed for performing maintenance.
- 5. Do not remove the name plate.**  
Improper maintenance or incorrect use of Operation Manual can cause equipment failure or malfunction. Also, there is a risk of losing conformity with safety standards.

### Mounting

#### Caution

- 1. When removing from / attaching to the valve manifold,**
  - **Do not apply excessive force to the Unit.**  
The connecting portions are firmly joined with seals.
  - **Take care not to get fingers caught.**  
Injury can result.
- 2. Do not drop, bump, or apply excessive impact.**  
Otherwise, this can cause damage, equipment failure or malfunction.
- 3. Observe the tightening torque range.**  
Tightening outside of the allowable torque range will likely damage the screw.  
IP65/IP67 cannot be guaranteed if the screws are not tightened to the specified torque.

### Mounting

#### Caution

- 4. When lifting a large size valve manifold, take care to avoid causing stress to the valve connection joint.**  
The connection joint of the product may be damaged.  
Because the product may be heavy, carrying and installation should be performed by more than one operator to avoid strain or injury.
- 5. When placing a manifold, mount it on a flat surface.**  
Torsion in the whole manifold can lead to trouble such as air leakage or contact failure.

### Wiring

#### Caution

- 1. Provide the grounding to maintain the safety of the product and to improve the noise immunity.**  
Provide a specific grounding as close to the product as possible to minimise the distance to grounding.
- 2. Avoid repeatedly bending or stretching the cable and applying a heavy object or force to it.**  
Wiring applying repeated bending and tensile stress to the cable can break the circuit.
- 3. Avoid miswiring.**  
If miswired, there is a danger of malfunction or damage to the product.
- 4. Do not wire while energising the product.**  
There is a danger of malfunction or damage to the product or input/output device.
- 5. Avoid wiring the power line and high pressure line in parallel.**  
Noise or surge produced by signal line resulting from the power line or high pressure line could cause a malfunction.  
Wiring of the product or input/output device and the power line or high pressure line should be separated from each other.
- 6. Check for the wiring insulation.**  
Defective insulation (contact with other circuits, improper insulation between terminals, etc.) may cause damage to the product or input/output device due to excessive voltage or current.



## Series EX500

# Specific Product Precautions 2

Be sure to read this before handling. Refer to the back cover for Safety Instructions. For 3/4/5 Port Solenoid Valve Precautions, refer to "Handling Precautions for SMC Products" and the Operation Manual on the SMC website, <http://www.smc.eu>

### Wiring

#### Caution

- 7. When the product is installed in machinery/equipment, provide adequate protection against noise by using noise filters etc.**  
Noise in signal lines may cause a malfunction.
- 8. When connecting wires, prevent water, solvent or oil from entering inside from the connector section.**  
Otherwise, this can cause damage, equipment failure or malfunction.
- 9. Avoid wiring patterns in which excessive stress is applied to the connector.**  
This may cause equipment failure or malfunction due to contact failure.

### Operating Environment

#### Warning

- 1. Do not use in an atmosphere containing an inflammable gas or explosive gas.**  
Use in such an atmosphere is likely to cause a fire or explosion. This system is not explosion-proof.

#### Caution

- 1. Select the proper type of enclosure according to the environment of operation.**  
IP65/67 is achieved when the following conditions are met.
  - 1) Provide appropriate wiring between the products using electrical wiring cables, communication connectors and cables with M12 connectors.
  - 2) Suitable mounting of the product and valve manifold.
  - 3) Be sure to mount a seal cap on any unused connectors.  
If using in an environment that is exposed to water splashes, please take measures such as using a cover.  
When the enclosure is IP40, do not use in an operating environment or atmosphere where it may come in contact with corrosive gas, chemical agents, seawater, water, or water vapor.
- 2. Provide adequate protection when operating in locations such as the following.**  
Failure to do so may cause a malfunction or equipment failure. The effect of countermeasures should be checked in individual equipment and machine.
  - 1) Where noise is generated by static electricity etc.
  - 2) Where there is a strong electric field
  - 3) Where there is a danger of exposure to radiation
  - 4) When in close proximity to power supply lines
- 3. Do not use in an environment where oil and chemicals are used.**  
Operating in environments with coolants, cleaning solvents, various oils or chemicals may cause adverse effects (damage, malfunction) to the product even in a short period of time.

### Operating Environment

#### Caution

- 4. Do not use in an environment where the product could be exposed to corrosive gas or liquid.**  
This may damage the product and cause it to malfunction.
- 5. Do not use in locations with sources of surge generation.**  
Installation of the product in an area around the equipment (electromagnetic lifters, high frequency induction furnaces, welding machine, motors, etc.), which generates the large surge voltage could cause to deteriorate an internal circuitry element of the product or result in damage. Implement countermeasures against the surge from the generating source, and avoid touching the lines with each other.
- 6. When directly driving a load (output device) which generates surge voltage by relay, solenoid valves or lamp, use a load that has an integrated surge absorption element.**  
When a surge generating load is directly driven, the product may be damaged.
- 7. The product is CE marked, but not immune to lightning strikes. Take measures against lightning strikes in your system.**
- 8. Keep dust, wire scraps and other foreign matter from entering inside the product.**  
This may cause equipment failure or malfunction.
- 9. Mount the product in such locations, where no vibration or shock is affected.**  
This may cause equipment failure or malfunction.
- 10. Do not use in places where there are cyclic temperature changes.**  
In case that the cyclic temperature is beyond normal temperature changes, the internal product is likely to be adversely affected.
- 11. Do not use in direct sunlight.**  
This may cause equipment failure or malfunction.
- 12. Observe the ambient temperature range.**  
This may cause a malfunction.
- 13. Do not use in places where there is radiated heat around it.**  
Such places are likely to cause a malfunction.





## Series EX500

# Specific Product Precautions 3

Be sure to read this before handling. Refer to the back cover for Safety Instructions. For 3/4/5 Port Solenoid Valve Precautions, refer to “Handling Precautions for SMC Products” and the Operation Manual on the SMC website, <http://www.smc.eu>

### Adjustment / Operation

#### Warning

1. **Do not perform operation or setting with wet hands.**  
There is a risk of electrical shock.

#### <Web server function>

2. **The valve operation test is a function which forcibly changes the signal status. Please check safety of the ambient environment and the device before using this function.**

This may cause injuries or equipment damage.

3. **If the communication line and PC are shut down during a valve operation test, the valve output status will be held (It remains in the output status before the communication line and/or PC was shut down). Please check safety of the ambient environment and the device when performing this function.**

This may cause injuries or equipment damage.

#### Caution

1. **Use a watchmaker's screwdriver with thin blade for the setting switch.**  
**When setting the switch, do not touch other unrelated parts.**

This may cause parts damage or malfunction due to a short circuit.

2. **Provide adequate setting for the operating conditions.**  
Failure to do so could result in malfunction.  
Refer to the Operation Manual for the setting switch.

3. **For details on programming and address setting, refer to the manual from the PLC manufacturer.**

The content of programming related to protocol is designed by the manufacturer of the PLC used.

### Maintenance

#### Warning

1. **Do not disassemble, modify (including circuit board replacement) or repair this product.**

Such actions are likely to cause injuries or equipment failure.

2. **When an inspection is performed,**
  - Turn off the power supply.
  - Stop the air supply, exhaust the residual pressure in piping and verify that the air is released before performing maintenance work.

Unexpected malfunction of system components and injury can result.

#### Caution

1. **When removing from / attaching to the valve manifold,**

- Do not apply excessive force to the Unit.

The connecting portions are firmly joined with seals.

- Take care not to get fingers caught.

Injury can result.

2. **Perform periodic inspection.**

Unexpected malfunction in the system composition devices is likely to occur due to malfunction of machinery or equipment.

3. **After maintenance, make sure to perform an appropriate functionality inspection.**

In cases of abnormality such as faulty operation, stop operation. Unexpected malfunction in the system composition devices is likely to occur.

4. **Do not use benzine and thinner for cleaning the product.**

Damage to the surface or erasure of the display can result. Wipe off any stains with a soft cloth.

If the stain is persistent, wipe off with a cloth soaked in a dilute solution of neutral detergent and wring out tightly, and then finish with a dry cloth.

### Other

#### Caution

1. **Refer to the catalogue of each series for Common Precautions and Specific Product Precautions on valve manifolds.**

#### ■ Trademark

EtherNet/IP® is a registered trademark of ODVA, Inc.  
QuickConnect™ is a trademark of ODVA.

## Safety Instructions

These safety instructions are intended to prevent hazardous situations and/or equipment damage. These instructions indicate the level of potential hazard with the labels of “Caution,” “Warning” or “Danger.” They are all important notes for safety and must be followed in addition to International Standards (ISO/IEC) <sup>1)</sup>, and other safety regulations.

### Danger:

**Danger** indicates a hazard with a high level of risk which, if not avoided, will result in death or serious injury.

### Warning:

**Warning** indicates a hazard with a medium level of risk which, if not avoided, could result in death or serious injury.

### Caution:

**Caution** indicates a hazard with a low level of risk which, if not avoided, could result in minor or moderate injury.

- 1) ISO 4414: Pneumatic fluid power – General rules and safety requirements for systems and their components.
- ISO 4413: Hydraulic fluid power – General rules and safety requirements for systems and their components.
- IEC 60204-1: Safety of machinery – Electrical equipment of machines. (Part 1: General requirements)
- ISO 10218-1: Robots and robotic devices - Safety requirements for industrial robots - Part 1: Robots.
- etc.

## Warning

### 1. The compatibility of the product is the responsibility of the person who designs the equipment or decides its specifications.

Since the product specified here is used under various operating conditions, its compatibility with specific equipment must be decided by the person who designs the equipment or decides its specifications based on necessary analysis and test results. The expected performance and safety assurance of the equipment will be the responsibility of the person who has determined its compatibility with the product. This person should also continuously review all specifications of the product referring to its latest catalogue information, with a view to giving due consideration to any possibility of equipment failure when configuring the equipment.

### 2. Only personnel with appropriate training should operate machinery and equipment.

The product specified here may become unsafe if handled incorrectly. The assembly, operation and maintenance of machines or equipment including our products must be performed by an operator who is appropriately trained and experienced.

### 3. Do not service or attempt to remove product and machinery/equipment until safety is confirmed.

1. The inspection and maintenance of machinery/equipment should only be performed after measures to prevent falling or runaway of the driven objects have been confirmed.
2. When the product is to be removed, confirm that the safety measures as mentioned above are implemented and the power from any appropriate source is cut, and read and understand the specific product precautions of all relevant products carefully.
3. Before machinery/equipment is restarted, take measures to prevent unexpected operation and malfunction.

### 4. Our products cannot be used beyond their specifications. Our products are not developed, designed, and manufactured to be used under the following conditions or environments. Use under such conditions or environments is not covered.

1. Conditions and environments outside of the given specifications, or use outdoors or in a place exposed to direct sunlight.
2. Use for nuclear power, railways, aviation, space equipment, ships, vehicles, military application, equipment affecting human life, body, and property, fuel equipment, entertainment equipment, emergency shut-off circuits, press clutches, brake circuits, safety equipment, etc., and use for applications that do not conform to standard specifications such as catalogues and operation manuals.
3. Use for interlock circuits, except for use with double interlock such as installing a mechanical protection function in case of failure. Please periodically inspect the product to confirm that the product is operating properly.

## Caution

**We develop, design, and manufacture our products to be used for automatic control equipment, and provide them for peaceful use in manufacturing industries.**

**Use in non-manufacturing industries is not covered.**

Products we manufacture and sell cannot be used for the purpose of transactions or certification specified in the Measurement Act.

The new Measurement Act prohibits use of any unit other than SI units in Japan.

## Limited warranty and Disclaimer/Compliance Requirements

The product used is subject to the following “Limited warranty and Disclaimer” and “Compliance Requirements”. Read and accept them before using the product.

### Limited warranty and Disclaimer

1. The warranty period of the product is 1 year in service or 1.5 years after the product is delivered, whichever is first. <sup>2)</sup> Also, the product may have specified durability, running distance or replacement parts. Please consult your nearest sales branch.
2. For any failure or damage reported within the warranty period which is clearly our responsibility, a replacement product or necessary parts will be provided. This limited warranty applies only to our product independently, and not to any other damage incurred due to the failure of the product.
3. Prior to using SMC products, please read and understand the warranty terms and disclaimers noted in the specified catalogue for the particular products.
- 2) Vacuum pads are excluded from this 1 year warranty.  
A vacuum pad is a consumable part, so it is warranted for a year after it is delivered. Also, even within the warranty period, the wear of a product due to the use of the vacuum pad or failure due to the deterioration of rubber material are not covered by the limited warranty.

### Compliance Requirements

1. The use of SMC products with production equipment for the manufacture of weapons of mass destruction (WMD) or any other weapon is strictly prohibited.
2. The exports of SMC products or technology from one country to another are governed by the relevant security laws and regulations of the countries involved in the transaction. Prior to the shipment of a SMC product to another country, assure that all local rules governing that export are known and followed.

## Safety Instructions

Be sure to read “Handling Precautions for SMC Products” (M-E03-3) before using.

## SMC Corporation (Europe)

<b>Austria</b>	+43 (0)2262622800	www.smc.at	office@smc.at
<b>Belgium</b>	+32 (0)33551464	www.smc.be	info@smc.be
<b>Bulgaria</b>	+359 (0)2807670	www.smc.bg	office@smc.bg
<b>Croatia</b>	+385 (0)13707288	www.smc.hr	office@smc.hr
<b>Czech Republic</b>	+420 541424611	www.smc.cz	office@smc.cz
<b>Denmark</b>	+45 70252900	www.smc.dk.com	smc@smcdk.com
<b>Estonia</b>	+372 651 0370	www.smcee.ee	info@smcee.ee
<b>Finland</b>	+358 207513513	www.smc.fi	smc.fi@smc.fi
<b>France</b>	+33 (0)164761000	www.smc-france.fr	supportclient@smc-france.fr
<b>Germany</b>	+49 (0)61034020	www.smc.de	info@smc.de
<b>Greece</b>	+30 210 2717265	www.smchellas.gr	sales@smchellas.gr
<b>Hungary</b>	+36 23513000	www.smc.hu	office@smc.hu
<b>Ireland</b>	+353 (0)14039000	www.smcautomation.ie	sales@smcautomation.ie
<b>Italy</b>	+39 03990691	www.smcitalia.it	mailbox@smcitalia.it
<b>Latvia</b>	+371 67817700	www.smc.lv	info@smc.lv

<b>Lithuania</b>	+370 5 2308118	www.smclt.lt	info@smclt.lt
<b>Netherlands</b>	+31 (0)205318888	www.smc.nl	info@smc.nl
<b>Norway</b>	+47 67129020	www.smc-norge.no	post@smc-norge.no
<b>Poland</b>	+48 222119600	www.smc.pl	sales@smc.pl
<b>Portugal</b>	+351 214724500	www.smc.eu	apoioclientept@smc.smces.es
<b>Romania</b>	+40 213205111	www.smcromania.ro	smcromania@smcromania.ro
<b>Russia</b>	+7 (812)3036600	www.smc.eu	sales@smcru.com
<b>Slovakia</b>	+421 (0)413213212	www.smc.sk	office@smc.sk
<b>Slovenia</b>	+386 (0)73885412	www.smc.si	office@smc.si
<b>Spain</b>	+34 945184100	www.smc.eu	post@smc.smces.es
<b>Sweden</b>	+46 (0)86031240	www.smc.nu	smc@smc.nu
<b>Switzerland</b>	+41 (0)523963131	www.smc.ch	helpcenter.ch@smc.com
<b>Turkey</b>	+90 212 489 0 440	www.smcturkey.com.tr	info@smcturkey.com.tr
<b>UK</b>	+44 (0)845 121 5122	www.smc.uk	sales@smc.uk

**South Africa** +27 10 900 1233    www.smcza.co.za    zasales@smcza.co.za